

installation

BMS (0-10V) option kit

Your Ideal installation guide

When replacing any part on this kit, use only spare parts that you can be assured conform to the safety and performance specification that we require. Do not use reconditioned or copy parts that have not been clearly authorised by Ideal Boilers.

i BOILERS *Ideal*
The High Efficiency Pioneers

INTRODUCTION

This kit is suitable only for the following boilers listed:

- imax W45
- imax W60
- imax W80
- imax W100
- imax W45P
- imax W60P
- imax W80P
- imax F80
- imax F120
- imax F160
- imax F200
- imax F240
- imax F280

KIT CONTENTS

PCB BMS (0-10V)	1 off
(bearing a single pole relay)	
PCB Mounting Plate	1 off
(imax W range only with Remote Indication PCB)	
PCB Ribbon Cable	1 off
(imax W range only with Remote Indiction PCB)	

This kit provides facility for wiring a 0-10 volt analogue input signal to facilitate external boiler control by a building management system (BMS). Additionally the kit provides a volt-free interface for wiring external alarm indication of 'boiler lock-out' condition. Once the kit is fitted the operating parameters of the boiler require re-configuration to facilitate its operation.

1 FITTING THE KIT

1. Switch off and disconnect the electricity supply to the boiler and any external controls.

imax W

2. Press the centre of the lower casing door to unlatch the magnetic catch and lower it.
3. Remove the two screws from the control fascia and lower it to expose the interior of the control box.

imax Xtra

4. Pull the front panel forwards at the top, lift off the bottom retaining lugs and remove.
5. Loosen 3 screws on one side of the inner front panel and undo the 3 screws from the other side. The panel will now slide to one side for removal.

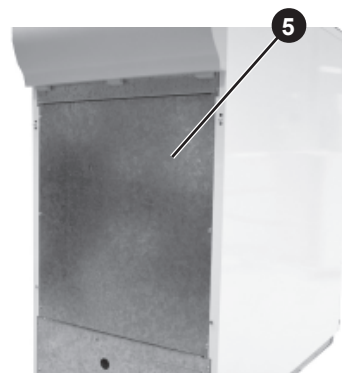
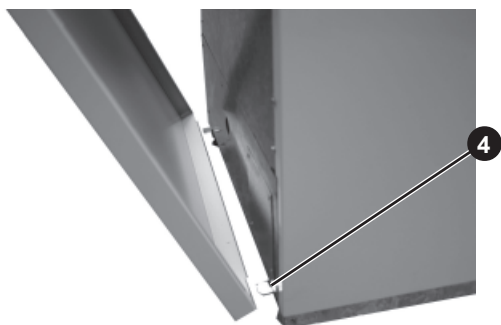
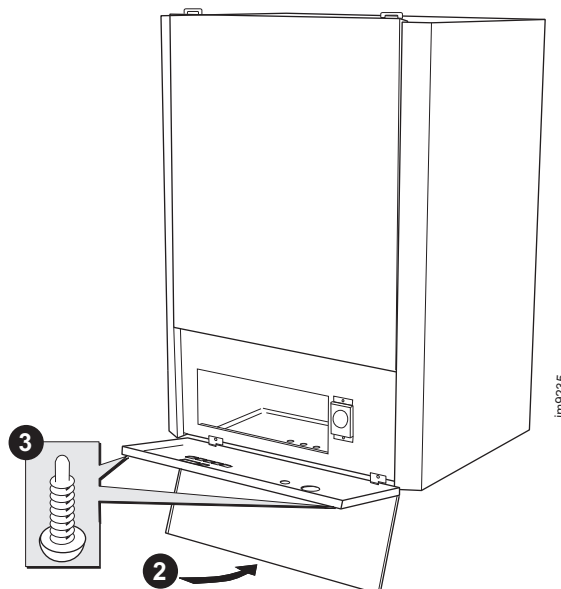

2 FITMENT OF BMS (0-10V) PCB

Carefully remove the BMS (0-10V) PCB from its protective packaging

imax W

1. Disconnect the communication ribbon from the remote indication PCB, located on the RHS pillars.
2. Remove the remote indication PCB from the pillars
3. Push the mounting plate supplied in the kit onto the 4 pillars.
4. Locate the remote indication PCB onto the upper set of pillars on the mounting plate and push on firmly.
5. Locate the BMS (0-10V) PCB on the lower set of pillars on the mounting plate and push on firmly.
6. Re-connect the communication ribbon to the remote indication PCB as originally set up.
7. Using the new communication ribbon connect the BMS (0-10V) PCB to the spare port on the MCBA control.

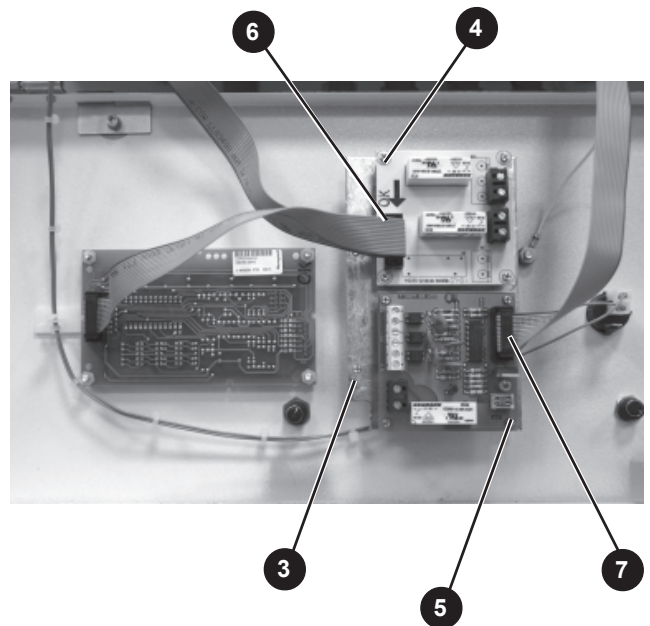
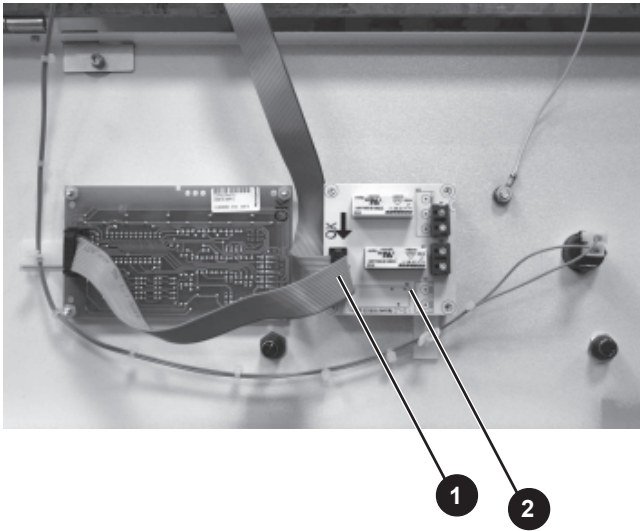

imax Xtra

Carefully locate the BMS 0-10 volt PCB onto the pillars whilst orientating the PCB screw terminals to face towards the left hand side of the boiler. Carefully clip the PCB onto the pillars, avoiding excessive distortion of the PCB.

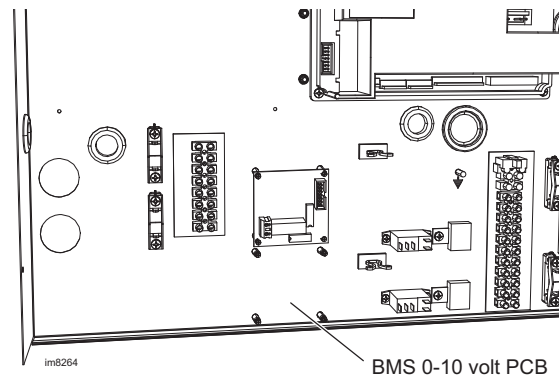

3 WIRING CONNECTIONS

imax W

Route the external BMS signal / indication cables into the boiler control box via the cable gland fittings located on the bottom panel of the boiler. Wire the cables directly to the screw terminals on the PCB as indicated in the diagram.

Re-assemble the front panels in reverse order.

imax Xtra

Route the external BMS signal cable onto the boiler control panel through the low voltage cable conduit running from the rear of the boiler on the left side. Wire the cable directly to the screw terminals on the PCB as indicated in the diagram. Anchor the cable using one of the cable clamps provided on the control panel.

Locate the flat ribbon cable connected to the boiler run/ alarm PCB. Plug the free connector, located on the end, into the socket on the right hand face of the BMS 0-10 volt PCB.

Re-assemble the front panels in reverse order.

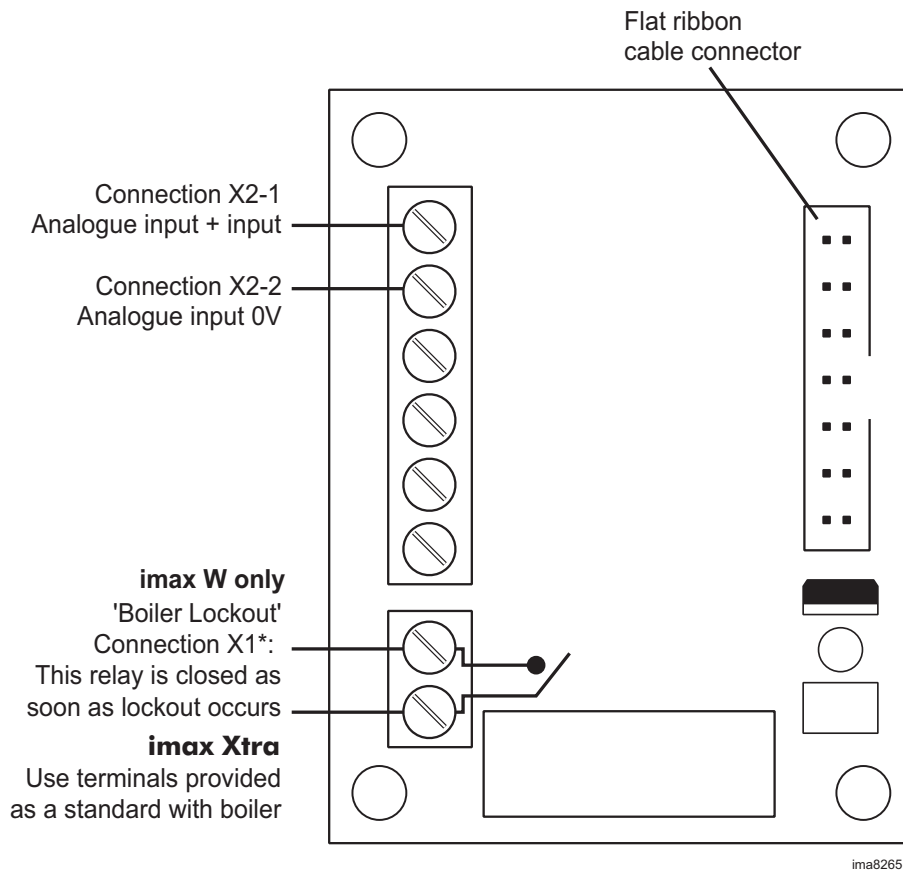



***Note:** Relays are suitable for switching 230VAC 8A resistive loads. If inductive loads are connected, take precautions such as derating the relay contacts (typically 20%) or apply suitable protection (e.g. RC network).

4 CHANGING CONTROL PARAMETERS - METHOD OF PROGRAMMING PARAMETERS FOR BMS (0-10V) OPERATION

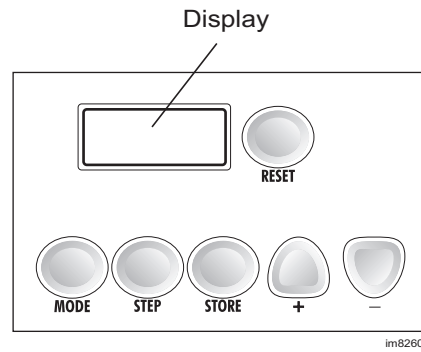
Maximum and minimum limits of analogue signal operation are set on the control panel using the parameter mode (with code) function.





Code Mode is entered from standby mode by pressing and holding the 'mode' and 'step' buttons.

Press	Display
 	

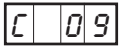
Press the 'step' button once and the display will show 'c' as the first digit and a random number in the 3rd and 4th digits.

Press	Display
	

Use the '+' or '-' button to change the code to 54.

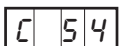
Press	Display
 or 	

Press and release the 'store' button, the display flashes to show the code has been accepted.

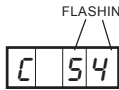
Press	Display
	







To leave code mode after parameter changes press reset. If no buttons are pressed the boiler automatically leaves code mode after 15 minutes.

5 CHANGING CONTROL PARAMETERS CONT'D

Access the 'PARA' mode using the 'mode' button and adjust the following parameters if necessary, whilst also referring to Frame 6. Press the '+' or '-' buttons to change the values.

The parameter setting can be stored by pressing and releasing the 'store' button, the new setting flashes twice to show it has been accepted. The new setting will become active when the parameter mode is left.

imax xtra

Press	Display	Description	Lower Limit	Upper Limit	Factory Setting
	PARA				
	P04 4.82	CH set flow temperature (°C) T, (max)	20	90	82
	P10 appears for 1 second .20	CH flow temperature (min) (°C) When using outside temperature sensor compensation	15	60	25
	P35 .05	CH modulation hysteresis off	00	10	05
	P40 .00	Blocking time CH (seconds) Minimum off period between CH demands to reduce cycling	00	30	00
	P45 .00	04=0-10V BMS: capacity 05=0-10V BMS: temperature			00

6 ANALOGUE CONTROL CHARACTERISTICS

The 0-10V BMS control signal can control the boiler's heating capacity or flow temperature operation.

0-10V CONTROL ON HEATING CAPACITY

To control the boiler on heating capacity set CH type (parameter 45) to 04. A heat-request is generated when the analogue input voltage >0.5V. The maximum boiler flow temperature is set by parameter 4. The voltage controls modulation by controlling the boiler fan speed (1.8V = minimum load, 10V = maximum load). The burner will be switched off when the flow temperature is greater than the CH set flow temperature (parameter 4) + hysteresis off (parameter 35).

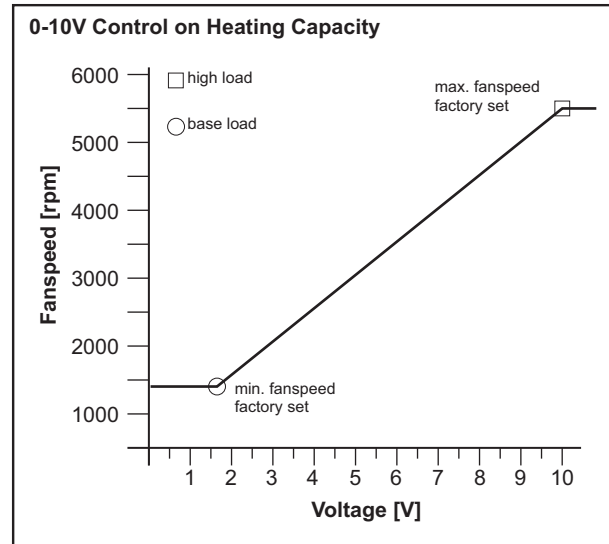

0-10V CONTROL ON FLOW TEMPERATURE

To control the boiler on flow temperature set CH type (parameter 45) to 05. A heat-request is generated when the analogue input voltage >0.5V. The voltage controls the set-value flow temperature (0V=0°C, 10V=100°C, but is top limited by the CH set flow temperature (parameter 4) and bottom limited by CH flow temperature min (parameter 10). The modulation is based on PI-control. The burner will be switched off when the flow temperature is greater than the CH set flow temperature (parameter 4) + hysteresis off (parameter 35).

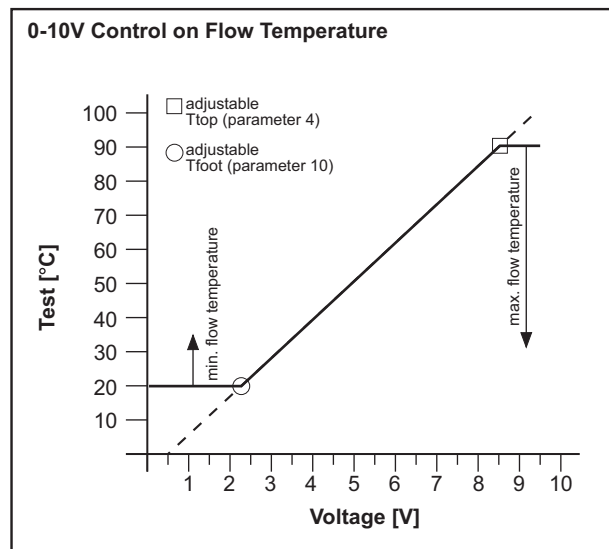

If the burner switches off because of CH set flow temperature + hysteresis off, the CH blocking time (parameter 40) always becomes active.

Technical Training

The Ideal Boilers Technical Training Centre offers a series of first class training courses for domestic, commercial and industrial heating installers, engineers and system specifiers. For details of courses please ring: 01482 498 432

Ideal Boilers, P.O. Box 103, National Ave, Kingston upon Hull, HU5 4JN. Telephone: 01482 492 251 Fax: 01482 448 858. Registration No. London 322 137.

Ideal Stelrad Group pursues a policy of continuing improvement in the design and performance of its products. The right is therefore reserved to vary specification without notice.



i Ideal BOILERS
The High Efficiency Pioneers

February 2009

UIN 204212 A02



Ideal Stelrad Group

Ideal Installer/Technical Helpline: 01482 498 376

www.idealboilers.com