

# High Efficiency Modular Boilers

Super Range



# Introduction - Ideal Commercial & Industrial

## Pioneering heating solutions since 1905

Here at Ideal, we understand that you want a reliable, long term partner that has the skills and expertise to deliver you a wide range of reliable and pragmatic solutions.

With over 100 years of manufacturing experience, you can be confident to know that our capabilities stretch beyond traditional boiler technologies Ideal Commercial Heating provides a range of condensing solutions both wall hung or floor mounted, all perfectly designed to meet your individual building requirements.

As well as being able to help you rise to the challenge of the UK building regulations, we also provide a dedicated support service throughout the design, planning and after sales stages, giving you total peace of mind that we will provide you with the complete one-stop solution, all from one manufacturer.

When you choose to partner with Ideal you can be confident to know that you're partnering with a British manufacturer that's supported by a dedicated national service team, delivering help and advice to you and your customers throughout the year.

We have been keeping British buildings warm for over a century and believe in making products which are reliable, energy efficient and easy to use, combining the latest technology with common sense engineering that make our products easy to specify, simple to install & maintain and most importantly are reliable.



# Contents

## Super Range

<b>4</b>	Introduction
<b>5-12</b>	Super Series 4 (50 - 600 kW)
<b>13-16</b>	Super Plus (200 - 600 kW)
<b>17-19</b>	Product Specification
<b>20-23</b>	System Requirements
<b>Ideal Service &amp; Support, Training</b>	
<b>25</b>	Ideal Service & Support
<b>26-27</b>	Training at Ideal Heating

## Super Range

### Introduction

The Ideal Commercial Heating Super range is the most successful modular boiler system on the market. Proven to deliver exceptional high efficiency commercial and industrial heating performance.

The Super range consists of the Super Series 4 comprising identical 50 kW modules with outputs from 50 kW to 600 kW and the Super Plus comprising of 100 kW modules with outputs from 200 kW to 600 kW.

Heat exchangers are sited in a combined casing/combustion chamber assembly, effectively creating semi-condensing conditions within each module. This design achieves efficiencies of up to 85% gross cv (94% nett cv) at both full and part load conditions. Because of its modular design, Super range eliminates oversizing problems to offer optimum operating efficiency. Maximum system load determines the appropriate number of modules for a given installation - from 50 kW (170,600 Btu/h) up to 600 kW (2,047,200 Btu/h). Sequence controlled operation automatically matches the number of modules firing to requirements, so reducing fuel consumption.

Ideal for simple vertical or horizontal assembly, Super range installation can save over 30% of the typical plantroom space normally used by conventional boilers. And the system incorporates a range of design innovations reducing boiler installation and servicing time.

Super efficient, straightforward to specify, easy to install and service. Ideal's Super range is the proven performer in high efficiency modular boiler systems.

## Super Range

### Super Series 4 50 - 600 kW

#### Super Series 4 50 - 600 kW

The Super Series 4 comprises of identical 50 kW modules with heat outputs from 50 kW to 600 kW, with the number of modules in use dependent on the maximum load. Fitted on slide rails, the modules are located in an insulated stainless steel boiler casing. The products of combustion first give up their heat to water flowing through the modules then are discharged.

The heat exchanger consists of extruded copper finned tubes in a circular arrangement around the gas burner. Copper tubes are expanded into cast iron headers, onto which cast iron cover plates are bolted.

Suitable for vertical or horizontal assembly, Super range installations can save over 30% of the typical plant room space normally used by conventional boilers.



### Super Series 4 50 - 600 kW

#### Features and Benefits



- 50 kW modules
- Vertical and horizontal models
- High efficiency 85% gross cv (94% nett cv)
- Low NOx emissions (class 5)
- Low noise
- Compact size
- Sequence controlled
- Easy to install and service
- Complete package - incorporating single flue outlet, gas and water headers included
- Remote indication contacts

#### Heat exchange module

Figure 1

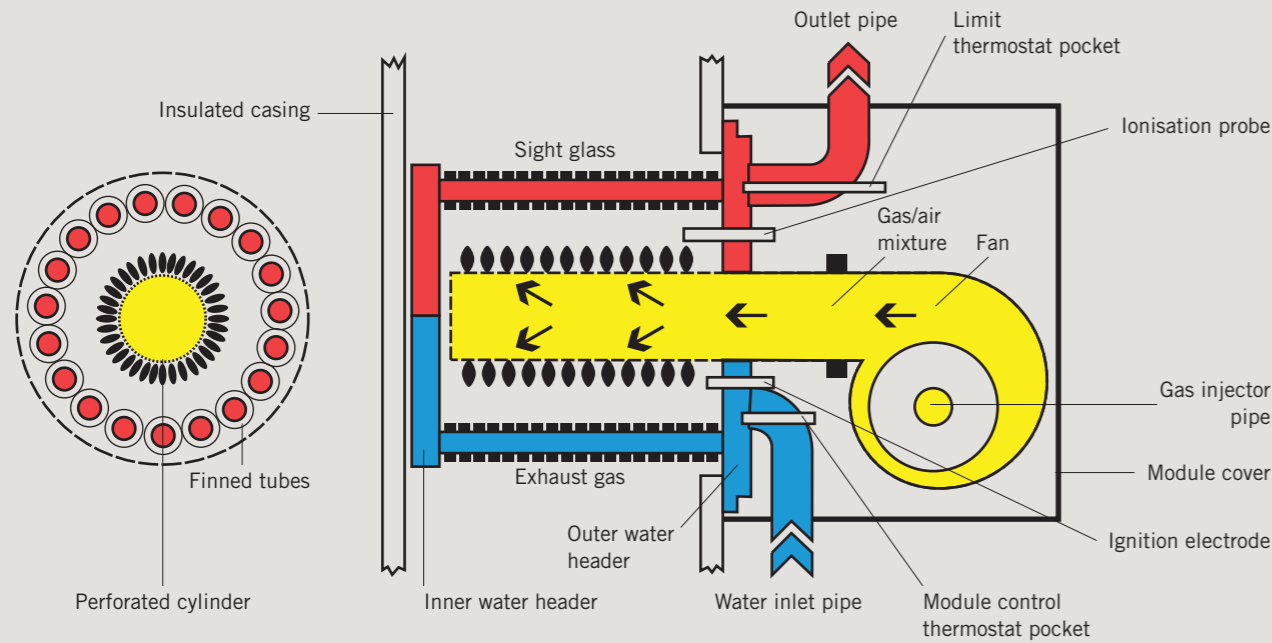

#### General data 50V - 300H

Model		50V	100V	150V	200V	250V	300V	150VA	250H	300H
No. of Modules		1	2	3	4	5	6	3	5	6
	kW	58.8	117.6	176.4	235.2	294.0	352.8	176.9	294.0	352.8
Boiler Input	Btu/h	200.6	401.3	601.9	802.5	1003.1	1203.8	601.9	1003.1	1203.8
	kW	50	100	150	200	250	300	150	250	300
Boiler Output	Btu/h	170.6	341.2	511.8	682.4	853.0	1023.6	511.8	853.0	1023.6
	m³/h	5.5	11.0	16.5	22.1	27.6	33.1	16.5	27.6	33.1
Gas Rate	ft³/h	195	389	584	779	973	1168	584	973	1168
	m³/s	0.027	0.055	0.082	0.110	0.137	0.164	0.082	0.137	0.164
Approx Flue Gas Volume at 120°C (248°F)	9.0% CO <sub>2</sub> 120°C	58	116	174	232	290	348	174	290	348
	9.0% CO <sub>2</sub> 248°F									
Hydraulic Resistance	kN/m²	12.5								
	in.w.g.	50								
Power Consumption	watts	150	300	450	600	750	900	450	750	900
Flow Tappings & Return Tappings	mm	40	50	65	65	80	80	65	80	80
	in	1½	2	2½	2½	3	3	2½	3	3
Maximum Static Water Head	m	61								
	ft	200								
Required Water Flow Rate +/-10%	l/s	1.07	2.14	3.21	4.28	5.35	6.42	3.21	5.35	6.42
	gal/m	14.1	28.2	42.3	56.4	70.5	84.6	42.3	70.5	84.6
Gas Inlet Connection	Rc	¾	1	1¼	1¼	1½	1½	1¼	1½	1½
	in. BSP	¾	1	1¼	1¼	1½	1½	1¼	1½	1½
Minimum Dynamic Gas Pressure Required at the Boiler Inlet for the Rated Input	mbar (gauge)	15.0								
	in.w.g.	6.0								
Electricity Supply		230V ~ 50Hz single phase								
Nominal Flue Size (to BS 835)	mm	125	175	200	250	250	300	200	250	300
	in	5	7	8	10	10	12	8	10	12
Diverter Outlet Socket Internal Diameter	mm	159	213	238	288	288	339	238	288	339
	in	6¼	8½	9½	11½	11½	13½	9½	11½	13½
Weight Modules	kg	53	106	159	212	265	318	159	212	318
	lb	116	232	348	464	580	696	348	580	696
Weight Casing / Insulation	kg	29.1	47.7	61.5	76.6	106.6	98.9	84.0	107.0	99.0
	lb	64.1	105.2	135.5	168.8	235.0	218.0	185.0	235.0	218.0
Weight Gas / Water Headers	kg	-	34	53.6	59.4	89.4	94.3	53.4	92.2	96.7
	lb	-	75	118	131	197	208	118	203	213
Water Content	l	4.5	11.9	20.7	26.2	37.7	44.5	21.7	39.7	44.5
	gal	1.0	2.6	4.6	5.9	8.3	9.9	4.9	8.8	9.9
Seasonal Efficiency	%	84.50	84.39	84.75	84.96	84.96	84.96	84.75	84.96	84.96

Note: To obtain gas consumption in l/s, divide gross heat input (kW) by a calorific value of 37.8 (MJ/m³).  
 Note: Flange sizes to BS 4504: Part 1: Table 16.



Super Series 4 50 - 600 kW

General data 350V - 600H

Model		350V	400V	450V	500V	550V	600V	450VA	500H	550H	600H
No. of Modules		7	8	9	10	11	12	9	10	11	12
Boiler Input	kW	411.6	470.2	529.2	583.0	646.8	705.6	529.2	583.0	646.8	705.6
	Btu/h	1404	1605	1805	2006	2207	2407	1805	2006	2207	2407
Boiler Output	kW	350	400	450	500	550	600	450	500	550	600
	Btu/h	1194	1365	1535	1706	1877	2047	1535	1706	1877	2047
Gas Rate	m³/h	38.6	44.1	49.7	55.2	60.7	66.2	49.7	55.2	60.2	60.7
	ft³/h	1363	1557	1752	1947	2143	2336	1752	1947	2143	2336
Approx Flue Gas Volume at 120°C (248°F)	9.0% CO <sub>2</sub> 120°C 9.0% CO <sub>2</sub> 248°F	m³/s	0.191	0.219	0.246	0.273	0.301	0.246	0.273	0.301	0.328
		ft³/m	406	464	522	580	638	696	522	580	638
Hydraulic Resistance	kN/m²	12.5									
	in.w.g.	50									
Power Consumption	watts	1050	1200	1350	1500	1650	1800	1350	1500	1650	1800
Flow Tappings & Return Tappings	mm	100	100	125	125	125	125	125	125	125	125
	in	4	4	5	5	5	5	5	5	5	5
Maximum Static Water Head	m	61									
	ft	200									
Required Water Flow Rate +/-10%	l/s	7.49	8.50	9.63	10.70	11.77	12.84	9.63	10.70	11.77	12.84
	gal/m	98.7	112.8	126.9	141.0	155.1	169.2	126.9	141.0	155.1	169.2
Gas Inlet Connection	Rc	2									
	in. BSP	2									
Minimum Dynamic Gas Pressure Required at the Boiler Inlet for the Rated Input	mbar (gauge)	15.0									
	in.w.g.	6.0									
Electricity Supply		230V ~ 50Hz single phase									
Nominal Flue Size (to BS 835)	mm	350	350	400	400	450	450	400	400	450	450
	in	14	14	16	16	18	18	16	16	18	18
Diverter Outlet Socket Internal Diameter	mm	400	400	450	450	501	501	450	450	501	501
	in	15½	15½	17½	17½	19½	19½	17½	17½	19½	19½
Weight Modules	kg	371	424	477	530	583	636	477	530	583	636
	lb	818	935	1052	1168	1282	1402	1052	1168	1282	1402
Weight Casing / Insulation	kg	134	126	197	190	182	175	197	190	182	175
	lb	295	278	435	418	402	386	435	418	402	386
Weight Gas / Water Headers	kg	260	263	311	313	315	318	298	300	302	304
	lb	573	580	686	690	694	701	657	661	665	670
Water Content	l	63.3	68.1	97.6	102.4	107.2	112.0	92.6	97.4	102.2	107.0
	gal	14.1	15.1	21.6	22.7	23.9	24.9	20.5	21.6	22.7	23.7
Seasonal Efficiency	%	84.96									

Note: To obtain gas consumption in l/s, divide gross heat input (kW) by a calorific value of 37.8 (MJ/m³).  
 Note: Flange sizes to BS 4504: Part 1: Table 16.

Boiler dimensions 50 kW - 150 kW

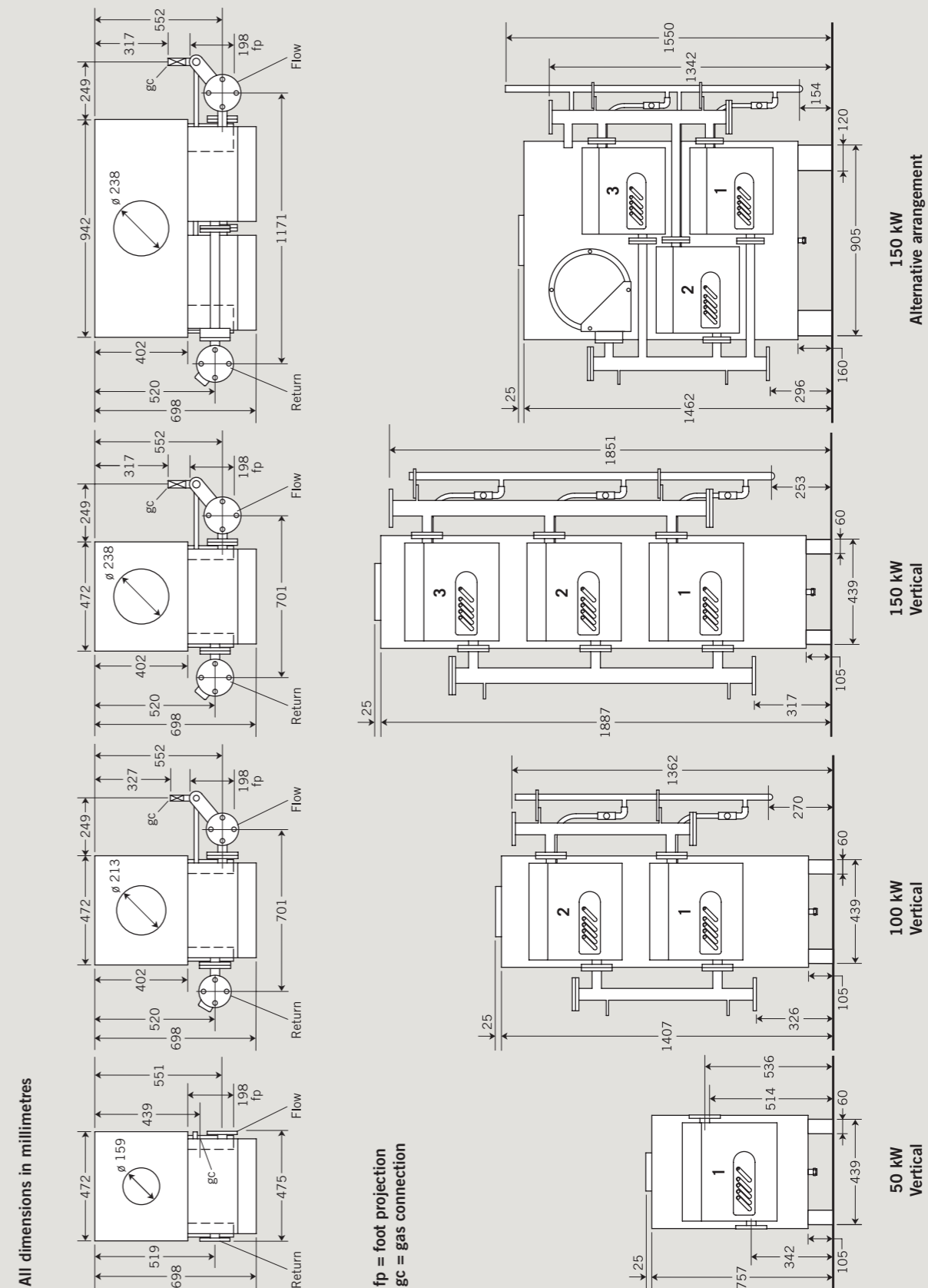

fp = foot projection  
 gc = gas connection



Super Series 4 50 - 600 kW

Boiler dimensions 200 kW - 300 kW

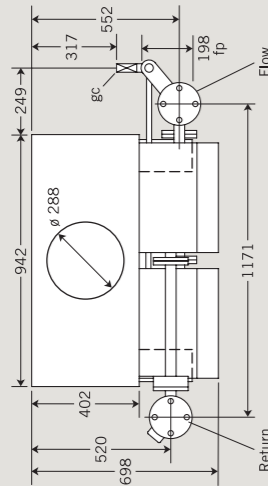
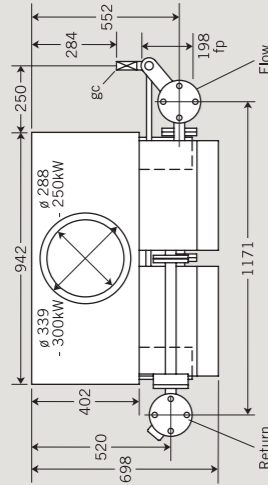
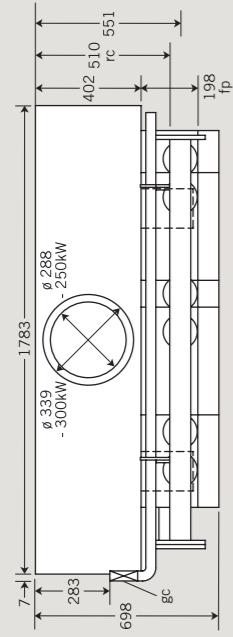

fp = foot projection  
gc = gas connection  
rc = return connection

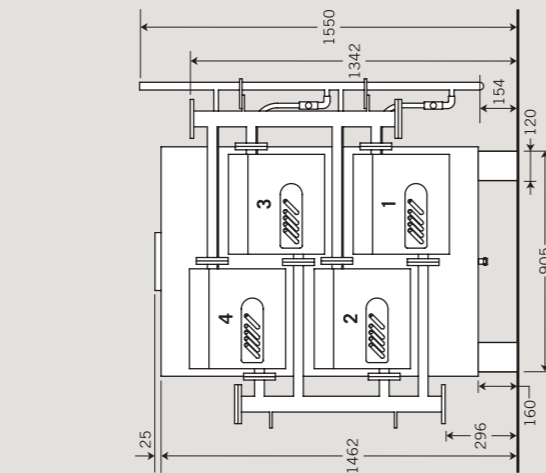
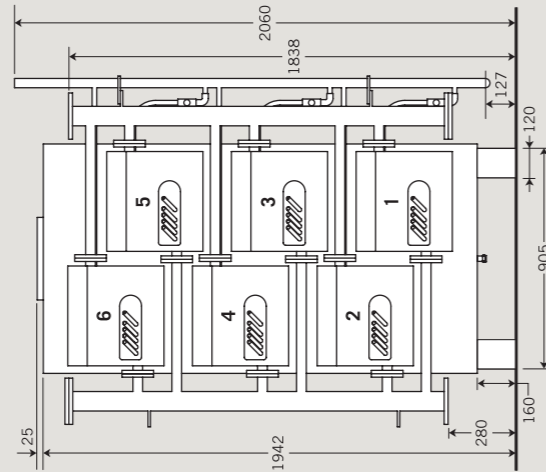
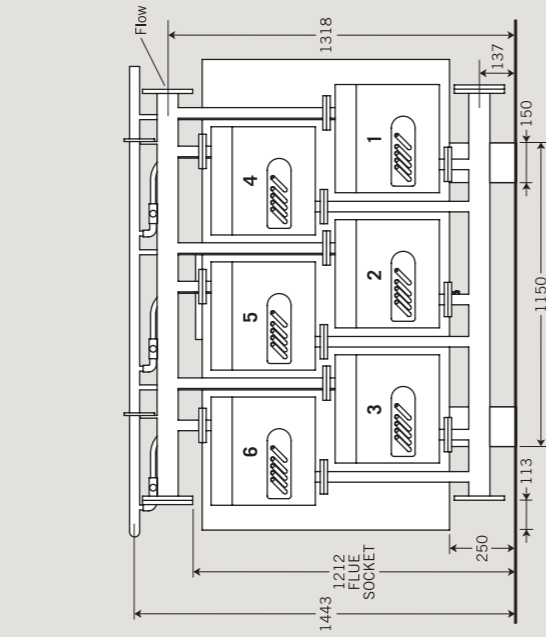

250 / 300 kW  
Horizontal

250 / 300 kW  
Vertical

200 kW  
Vertical

Boiler dimensions 350 kW - 600 kW

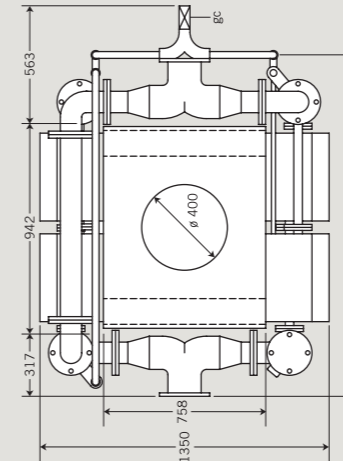
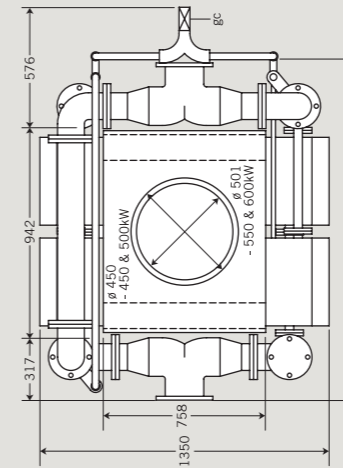
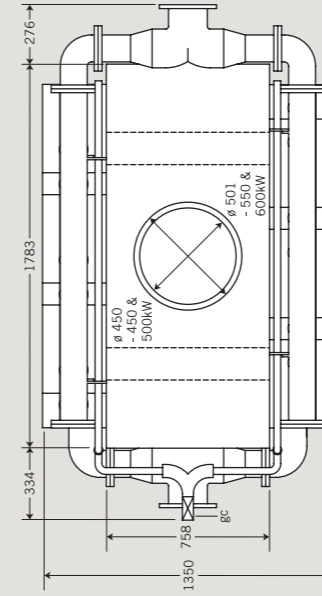

All dimensions in millimetres

gc = gas connection

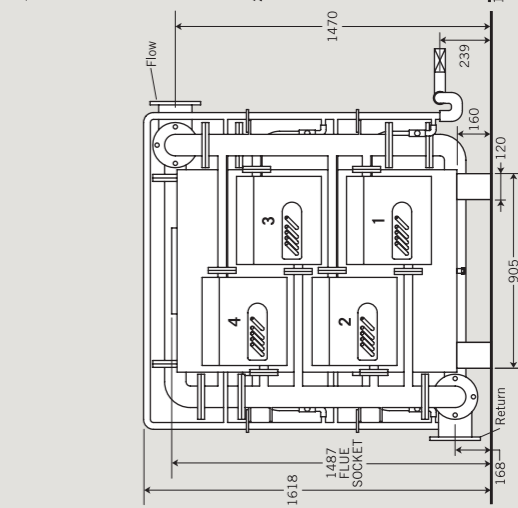
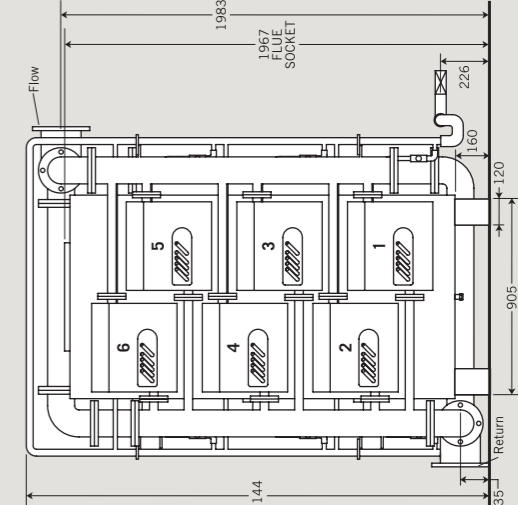
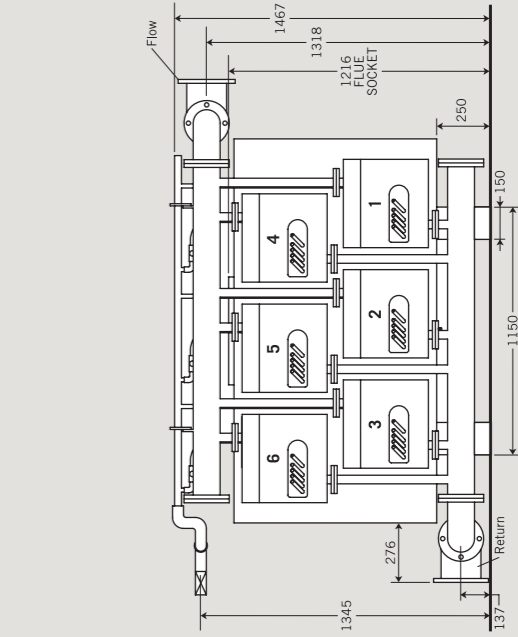

450 / 600 kW  
Horizontal

450 / 600 kW  
Vertical

350 / 400 kW  
Vertical

**Super Series 4 50 - 600 kW**

**Boiler clearances**

All dimensions in millimetres

Diagram applicable for 50 - 300 kW models

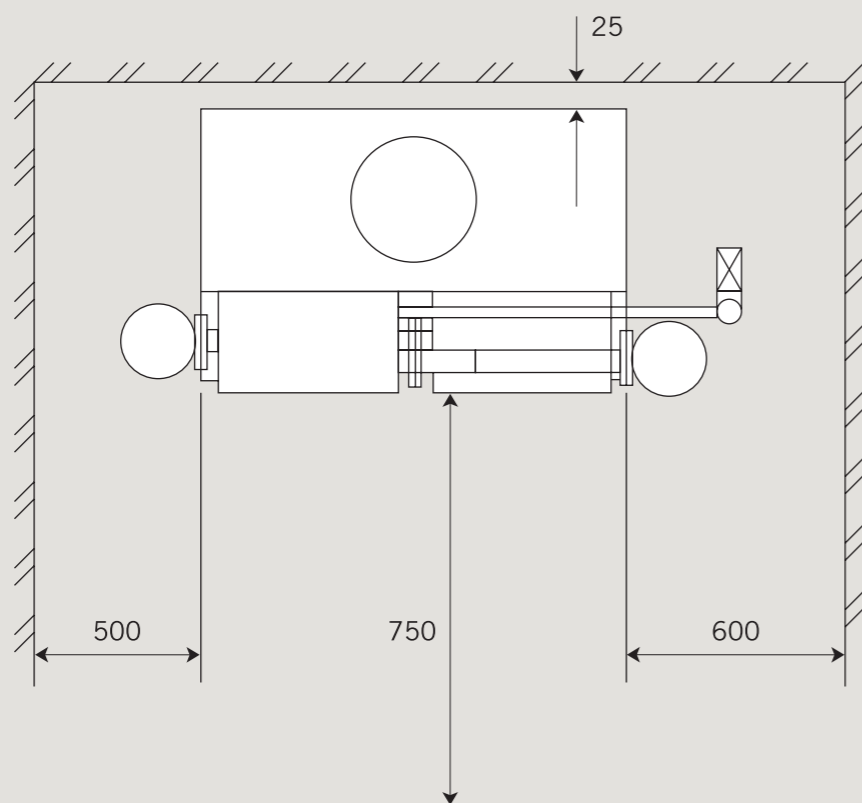
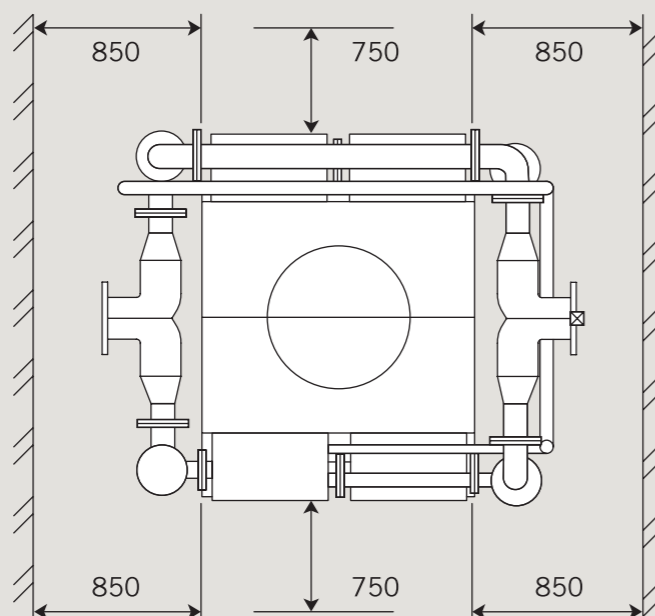

Diagram applicable for 350 - 600 kW models



**Super Range**

**Super Plus 200 - 600 kW**

**Super Plus 200 - 600 kW**

The Super Plus comprises of identical 100 kW modules with outputs from 200 kW to 600 kW.

Heat exchangers are sited in a combined casing/combustion chamber assembly, effectively creating semi-condensing conditions within each module. The Super Plus can achieve efficiencies of up to 85% gross cv (94% nett cv) at full and part load conditions. Maximum system load determines the appropriate number of modules for a given installation up to 600 kW. Sequence controlled operation automatically matches the number of modules firing to requirements, so reducing fuel consumption.

The heat exchanger is constructed in aluminium silicon alloy. The front cover plate is cast iron with similar flow and return elbows to the Super Series 4. The mating surfaces are ground and a seal is made with gaskets. Each module is pressure tested to 11 bars.

Super efficient, straightforward to specify, easy to install and service. Ideal's Super range is an established performer in high efficiency modular boiler systems.



### Super Plus 200 - 600 kW

#### Features and Benefits



- 100 kW modules
- Horizontal assembly
- High efficiency 85% gross cv (94% nett cv)
- Low NOx emissions (class 5)
- Low noise
- Ultra compact
- Sequence controlled
- Easy to install and service
- Complete package - incorporating single flue outlet, gas and water headers included
- Optional remote indication kits



#### General data

Model		200/S	300/3	400/4	300/3 Alternative	400/4 Alternative	500/5	600/6
<b>No. of Modules</b>		<b>2</b>	<b>3</b>	<b>4</b>	<b>3</b>	<b>4</b>	<b>5</b>	<b>6</b>
Boiler Input gross	kW	235	353	471	353	471	588	706
	Btu/h	802.9	1204.4	1607.0	1204.4	1607.0	2006.2	2408.8
Boiler Output	kW	200	300	400	300	400	500	600
	Btu/h	682.4	1023.6	1364.8	1023.6	1364.8	1706.0	2047.2
Gas Rate	m³/h	22.1	33.1	44.2	33.1	44.2	55.1	66.2
	ft³/h	778.8	1168.0	1558.7	1168.0	1558.7	1945.8	2336.4
Approx Flue Gas Volume 8.5% CO <sub>2</sub> 100°C at 120°C (248°F)	8.5% CO <sub>2</sub> 100°C m³/s	0.109	0.164	0.218	0.164	0.218	0.273	0.327
	8.5% CO <sub>2</sub> 212°F ft³/m	231	397	463	347	463	578	694
Hydraulic Resistance	mbar	98						
	in.w.g.	39						
Power Consumption	watts	400	600	800	600	800	1000	1200
Flow Tappings & Return Tappings	mm	65	125	125	125	125	125	125
	in	2½	5	5	5	5	5	5
Maximum Static Water Head	m	61						
	ft	200						
Required Water Flow Rate +/-10%	l/s	4.3	6.5	8.6	6.5	8.6	10.8	12.9
	gal/m	56.8	85.2	113.6	85.2	113.6	142.0	170.4
Gas Inlet Connection	Rc	1½	2	2	2	2	2	2
	in. BSP	1½	2	2	2	2	2	2
Minimum Dynamic Gas Pressure Required at the Boiler Inlet for the Rated Input	mbar (gauge)	14.6	14.8	15.1	14.8	15.1	15.5	16
	in.w.g.	5.8	5.9	6.1	5.9	6.1	6.2	6.4
Electricity Supply		Nominal 230V ~ 50Hz single phase						
Nominal Flue Size (to BS 835)	mm	250	350	350	450	450	450	450
	in	10	14	14	18	18	18	18
Diverter Outlet Socket Internal Diameter	mm	288	401	401	500	500	500	500
	in	11.4	15.8	15.8	19.7	19.7	19.7	19.7
Weight Modules	kg	138.4	207.6	276.8	207.6	276.8	346.0	415.2
	lb	305.0	457.5	610.0	457.5	610.0	762.5	915.0
Weight Casing / Insulation	kg	134	144	144	208	208	208	208
	lb	295	318	318	459	459	459	459
Weight Gas / Water Headers	kg	36.1	47.6	47.6	62.4	62.4	62.4	62.4
	lb	79.7	104.9	104.9	137.5	137.5	137.5	137.5
Water content	l	19.8	29.7	39.6	29.7	39.6	49.5	59.4
	gal	4.4	6.5	8.7	6.5	8.7	10.9	13.1
Seasonal Efficiency	%	84.12	84.69	84.96	84.67	84.96	84.96	84.96

Note: To obtain gas consumption in l/s, divide gross heat input (kW) by a calorific value of 37.8 (MJ/m³).  
 Note: Flange sizes to BS 4504: Part 1: Table 16.



## Super Plus 200 - 600 kW

### Boiler dimensions and clearances

All dimensions in millimetres

#### Super Plus 200/S

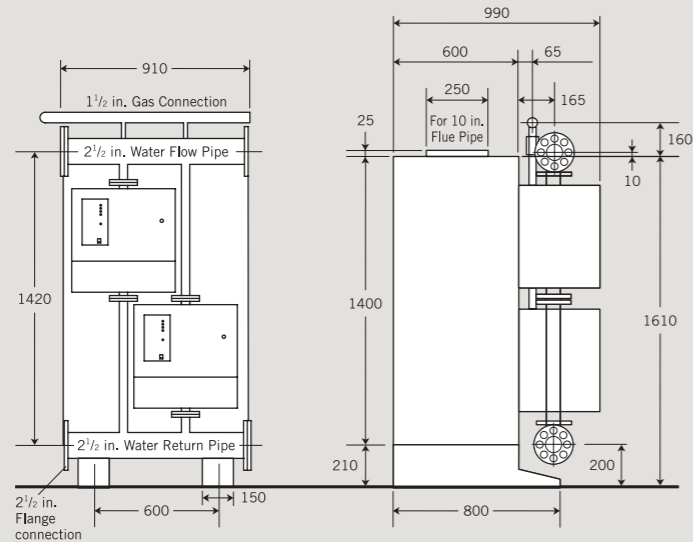

#### Super Plus 300/3 & 400/4

#### Super Plus 500/5 & 600/6

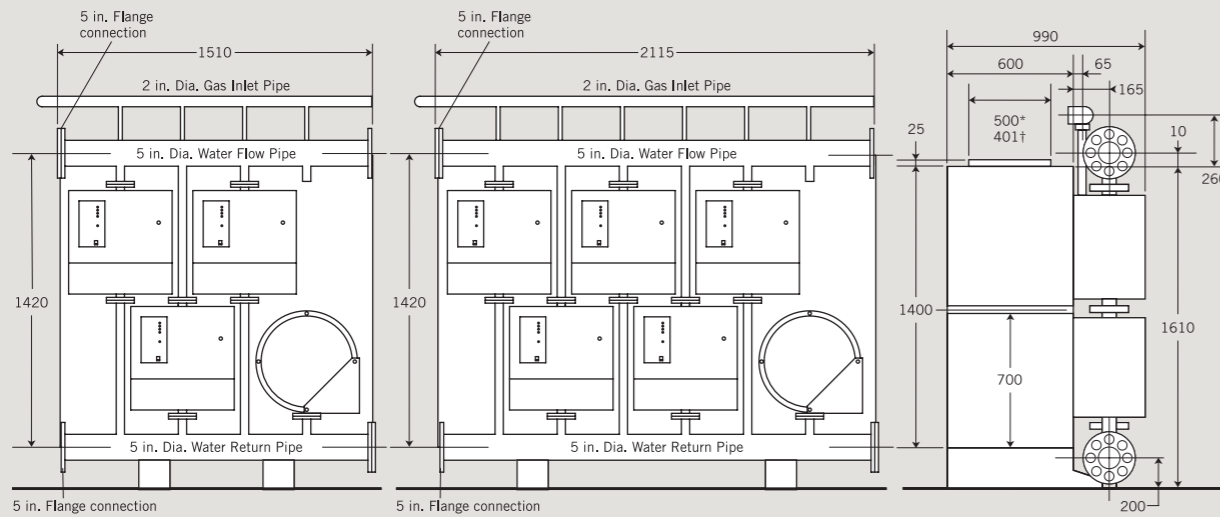

500\* for 18in. Flue pipe = Super Plus 500/5 & 600/6  
400† for 14in. Flue pipe = Super Plus 300/3 & 400/4

Note:  
Headroom must be the boiler height plus any pipework and flue requirements.

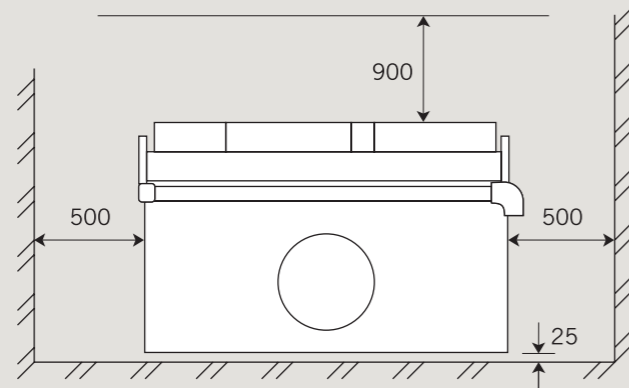

### Product specification

#### Performance

Heat output from each boiler module is 50 kW (Super Series 4) and 100 kW (Super Plus) with the number of modules in use dependent on the maximum load. Fitted on slide rails, the modules are located in an insulated stainless steel boiler casing. The products of combustion first give up their heat to water flowing through the modules then are discharged.

Water flows continuously through all the modules on the reverse return principle. It enters the return header on the left hand side of the boiler and then flows through the modules to the flow header on the right hand side. As the load is satisfied the upper module switches off first, then the middle, and lastly the lower module. Water flowing through the upper modules is kept warm by exhaust gas from lower modules which are firing. There is only a minimal loss of efficiency as modules shut down. Modules are connected in parallel across the two headers via flexible hose connections on boilers of 200 kW output and above.

The Super range complies with Building Regulations 2010 - Conservation of Fuel & Power (Part L2).

Approved efficiency is approx 94% net (85% gross) full load, at part load high efficiencies are maintained at virtually full load levels.

Boiler	Range	Certificate No.	Notified Body	Reference
Super Series 4	50 - 600 kW models	BE-87/97/4/M1	Advantica Technologies Ltd	0087
Super Plus	200 - 600 kW models	BE-87/97/4/M1	Advantica Technologies Ltd	0087

#### Construction

The stainless steel boiler casing is externally insulated with stucco finish, aluminium-faced insulation. Module covers are stove-enamelled orange. Super Series 4 - The heat exchanger consists of extruded copper finned tubes in a circular arrangement around the gas burner. Copper tubes are expanded into cast iron headers, onto which cast iron cover plates are bolted. Super Plus - The heat exchanger is constructed in the same manner but in aluminium alloy. The front cover plate is cast iron with similar flow and return elbows. The mating surfaces are ground and a seal

is made with gaskets. Each module is pressure tested to 11 bars (160 lb/in<sup>2</sup>). The module water inlet and outlet castings are 1 1/2" nominal bore and are connected to the flow and return headers with standard flanges to BS 4504. The buoyancy of hot gases from the gas burner is overcome by using a slotted aluminium distribution screen arranged around the outside of the finned tubes. The slots have sufficient resistance to ensure even gas flows over the finned tubes.

#### Burner

The burner is a perforated stainless steel cylinder producing a perfectly symmetrical gas flame. Gas and air in the correct proportions are pre-mixed in the burner fan which blows the gas/air mixture into the inside of the burner. A mixture distribution cone ensures even flow through holes in the cylindrical burner. Hot products of combustion flow radially outwards

around the finned tubes, giving up their heat to the water flowing through the tubes. Exhaust gases are then discharged into the boiler casing. Ignition and burner performance can be observed through the sight glass mounted on the front plate.

#### Options

Boiler	Super Series 4	Super Plus
Water Flow Switch for Boiler Protection in the event of Pump failure	✓	✓
External Sequence Control Kit	✓	
Remote Indication of Boiler on, Lockout and Overheat of each Module		✓
Module Blanking Off Pack	✓	✓

### Product specification

#### Gas controls

Each module has the following items in the gas supply train:

- Module gas cock on gas header branch
- Twin a.c. solenoid valve
- Gas air control unit
- Gas injector

The positive and negative pressure lines from the fan act on the diaphragm of the gas/air control unit (Super Plus: gas pressure switch). This allows gas to pass to the burner in proportion to the amount of air delivered by the fan, thereby accommodating variations in flue draught. A closed flue will allow no gas to pass. The minimum dynamic gas supply pressure required at the inlet to the boiler is 15 mbar (6 in. w.g.) with all modules firing. Maximum gas supply pressure is 25 mbar (10 in. w.g.).

#### Electrical controls

Each module has its own independent complete control system incorporating:

To achieve correct matching of boiler output and variations in load, modules switch in sequence automatically. The electronic control thermostat senses return water temperature to each module and makes simple adjustments quickly and accurately. The electronic control arrangements also provide step-start ignition of modules on initial light-up.

Boiler	Super Series 4 / Super Plus
2 x 2 PCB with separate Spark Generator	✓
Ignition Electrode	✓
Ionisation Probe	✓
Adjustable Water Temperature Electronic Control Thermostat	✓
Non-adjustable Limit Thermostat with Manual Reset	✓
On/off Switch	✓
LEDs to Provide Visual Indication of Mains On, Burner On	✓
Ignition Lockout and Overheat Lockout	✓
Module Electrical Plug	✓

#### Packing

Boilers are supplied in the following packs:-

Site assembly and commissioning is available on request.

Boiler	Super Series 4 / Super Plus
Boiler Casing	✓
Water Headers	✓
Gas Header	✓
Modules	✓

#### Operation

##### Super Series 4

In certain conditions the normal mode of boiler operation is preceded by a period in which the complete boiler casing is given a three volume air change. In the case of a single 50 kW boiler with no wiring centre, only its own 5 second nominal pre-purge period occurs. When the module electronic thermostat calls for heat the fan switches on and purges the combustion chamber for 15 seconds. Then the ignition spark is generated from the ignition electrode to the burner and the gas valves are opened.

through a multi-hole plate to the burner, where it is ignited. The flame is sensed via the ionisation probe and the PCB control. The valves remain open until the thermostat is satisfied.

**low NOx (Class 5)  
performance for life**

##### Super Plus

When the electronic thermostat calls for heat and no modules are firing, all fans will purge the casing for 70 seconds. The fan from the first module called upon will then purge its own combustion chamber for an additional 35 seconds and each subsequent module likewise prior to the start of the ignition sequence. Then the ignition spark is generated from the ignition electrode to the burner and the gas valves are opened.

The module is protected against blockage of the burner, heat exchanger, or flue and against fan failure by the compensating valve set. This senses the differences in pressure across the multi-hole plate and controls the gas injector pressure according to the amount of air flow. After combustion, the products flow past the finned tubes and through the gas distribution screen into the boiler casing, so giving up heat to the water flowing through the tubes.

Gas is delivered through the injector to the distribution plate at the inlet to the fan. This pre-mixes the gas with the air. It then passes from the fan

#### System application

The Super range is designed for central heating of commercial/industrial premises and also for supplying domestic hot water via a calorifier or plate heat exchanger. It is suitable for open vented and pressurised systems and can be connected to fully pumped, open vented or pressurised central heating, indirect domestic hot water and combined systems.

Note: The Super range is not suitable for direct hot water supply or gravity heating/hot water systems.

Boiler	Super Series 4 / Super Plus
Maximum Static Head	61 metres (200 feet)
Maximum Working Pressure	6 bar (87psi)
Maximum Design Flow Temperature	82°C (180°F)

#### Quality

As with all Ideal Commercial boilers, the Super range is engineered to the highest quality standards. Ideal Commercial boiler products meet or exceed the requirements of all relevant standards. Before dispatch each module is fired and the control system, fan and burner are fully tested. The control valve is also adjusted to give the correct gas flow rate. Ideal Commercial Heating is recognised as a World Class Manufacturer.

**assurance of quality  
BS EN ISO 9001: 2008**

**Environmental  
Management System  
ISO 14001: 2004**

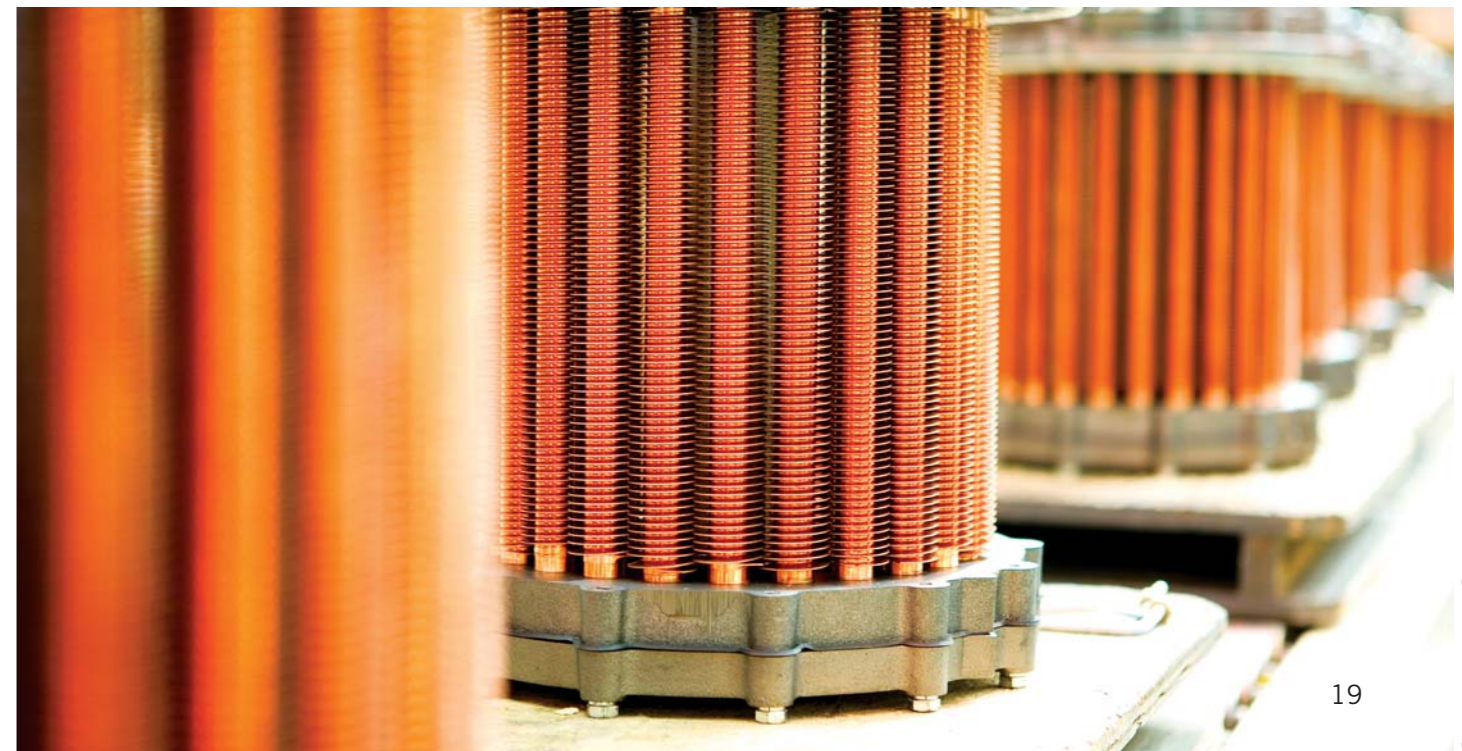

## System requirements

### Installation

For safety, a competent Gas Safe Registered installer must fit this appliance. Gas Safe Register requires its members to work to satisfactory standards.

Boiler installation should comply with relevant British Standard Specifications, Codes of Practice, and current Building Regulations, together with any special regional requirements of the Local Authorities, Gas Supplier and Insurance Company, and in particular:

BS 6891: Low pressure installation pipes, BS 6644: Installation of Gas Fired Boilers, BS 6880: Part 1-3 Central Heating by low pressure hot water, CP 342.2 Centralised hot water supply, British Gas publications IGE/UP/10 Installation of gas appliances in industrial and commercial premises.

All electrical wiring must comply with IEE Regulations for the electrical requirement of buildings.

Manufacturer's notes must not be taken as overriding statutory obligations.

vertical or horizontal models,  
easy to install

Minimum clearances from walls or other fixed objects to allow for installation, maintenance, and the free access of combustion air are shown in the boiler clearance diagram.

The Super range is easy to install. Even the largest boiler in the range will go through a standard doorway. If the water headers and the modules are

removed from the boiler casing, then one man can easily handle up to the 100kW unit, and two men up to the largest size. Assembly on site does not require any special tools. Because of the very high efficiency of the Super range precautions must be taken to provide condensate drains at the lowest bend in the flue system. A drainpipe, suitable for connection to 22mm pipe, is located at the bottom of the boiler casing. Condensation will occur only on warming up, when the return water temperature is below 55°C (131°F) - the dew point of water.

To ensure efficient and reliable boiler operation:

- The constant water flow through the boiler, within 10% of that indicated in the data table, must be maintained at all times when any of the modules are operating. At these flow rates, the hydraulic resistance is Super Series 4 125mbar (50 in. w.g.) or Super Plus 98mbar (39 in. w.g.) plus or minus 20% irrespective of boiler size.
- Protection against circulating pump failure must be provided.
- The chimney system must be CLASS 1 specification and be lined and insulated with the equivalent of 50mm (2in) of mineral wool. A drainage point must be provided.
- The chimney draught must be controlled between neutral and 0.2mbar (0.08 in. w.g.).
- Boiler house cleanliness is important and concrete floors should be sealed to keep dust levels down to a minimum.
- Regular maintenance by competent personnel is essential to the safe and reliable operation of the boiler.

Full details of these requirements are given in the Installation and Servicing Instruction books available on request from Ideal Commercial Heating.

### Ventilation

Detailed recommendations for air supply are quoted in BS 6644:2005

The following notes are for general guidance and the Standard should be consulted for full information.

#### Natural Ventilation

Permanent openings at low and high level communicating directly with the outside air must be provided. The total minimum free area of the openings must be as follows:

#### Low level (inlet)

- Required area (cm<sup>2</sup>) per kW of total rated input (nett).

Boiler Room	Enclosure
4	10

#### High level (outlet)

- Required area (cm<sup>2</sup>) per kW of total rated input (nett).

Boiler Room	Enclosure
2	5

Note: Where a boiler installation is to operate in summer months (e.g. DHW) additional ventilation requirements are stated if operating for more than 50% of time.

#### Mechanical Ventilation

Air can be supplied:

- By a fan connected to a low level opening and discharged naturally via one or more high level openings.
- By a fan connected to a low level opening and discharged by means of a second fan at a high level opening.

Note: Any fan installed for extraction purposes must not cause a negative pressure (relative to the outside atmosphere) to develop in the boiler house as this will affect burner performance.

The air flow rates for forced draught boilers are calculated from the formula.

#### Inlet air

- 2.6m<sup>3</sup>/h per kW of rated heat input (net).

#### Extract air

- 1.35m<sup>3</sup>/h +/- 0.18m<sup>3</sup>/h per kW of rated heat input (net).

All air inlet and extract fans must be fitted with automatic controls causing safety shutdown or lockout of the boiler(s) in the event of inlet or extract air flow failing.

### Water treatment

The Super Plus boiler has an aluminium alloy heat exchanger. The ONLY water treatments Ideal Commercial Heating have approved are 'Ferrox Copal' and 'Sentinel X100' (current suitability should be confirmed with the manufacturer). ANY OTHER treatment will render the guarantee of Ideal Commercial Heating for this product INVALID. The above is not applicable to the Super Series 4.

Water contained in all heating and indirect hot water systems, particularly open vented systems, requires basic treatment. It is wrong to assume that because boilers are operating in conjunction with what is an apparently closed circuit, an open vented system will not under normal circumstances allow damage or loss of efficiency owing to hardness salts and corrosion once the initial charge of water has been heated several times. One millimetre of lime reduces the heat conversion from flame via metal to water by 10%. In practice the accumulation of these salts is liable to cause noises from the boiler body or even premature boiler failure. Corrosion and the formation of black iron oxide sludge will ultimately result in premature radiator failure.

Open vented systems are not completely sealed off from the atmosphere, because it is necessary to provide a tank open to atmosphere if proper venting and expansion of system water is to be achieved. The same tank is used to fill the system with water and it is through the cold feed pipe that system water expands into the tank when the boiler passes heat into the system. Conversely, when the system cools, water previously expanded is drawn back from the tank into the system together with a quantity of dissolved oxygen.

Even if leakage from the heating and hot water system is eliminated there will be evaporation losses from the surface of the tank. Depending on ambient temperature these may be high enough to evaporate a large portion of the system water capacity over a full heating season.

Corrosion will always occur within a heating/hot water system to a greater or lesser degree irrespective of water characteristics, unless the initial fill water from the mains is treated. Even the water in closed systems will promote corrosion unless treated.

For these reasons, Ideal Commercial Heating strongly recommends that when necessary the system be thoroughly cleaned prior to the use of a stable inhibitor which does not require continual topping up to combat the effects of hardness, salts, and corrosion on the heat exchanger and its associated systems.

The company advises direct contact with major water treatment specialists such as Sentinel Performance Solutions, The Heath Business and Technical Park, Runcorn, Cheshire Telephone: 0800 389 4670 or Ferrox Manufacturing Co. Ltd., Cookson Electronics, Forsyth Road, Sheerwater, Woking, Surrey GU21 5RZ Telephone: 01799 521133 for technical information.

### Flue systems

Depending on particular site conditions the flue size required may be as much as two sizes smaller than that required for a conventional atmospheric gas boiler of similar output. The fitting of a draught stabiliser will be necessary on all individual boilers. In certain circumstances it may be possible to use a chimney sized smaller than the flue connection provided on the boiler.

#### Super Plus

- 300/3 (3 in 400 casing)
- 300/3 alternative (3 in 600 casing)
- 400/4 alternative (4 in 600 casing)
- 500/5 (5 in 600 casing)

The output of these boilers can be increased by the removal of blank plates and the fitting of additional modules provided that the flue system is sized for the higher output on initial installation.

Flues and terminal positions should be designed with strict regard to the requirements of BS 6644, IGE UP/10 Edition 3 and the Building Regulations Part J as appropriate. Particular attention should be paid to these for multiple boiler installations and if required, the Clean Air Act.

### single flue outlet

Existing brick chimneys can be used provided they are lined, insulated and drained. Super range boilers are suitable for fan diluted or induced draught fan flue systems. The following sizes of boiler are supplied with one or more blanking plates fitted:

#### Super Series 4

- Alternative 150
- 250 vertical and horizontal
- 350 vertical
- 450 to 550 vertical and horizontal models



### System requirements

#### System design

The Super range is suitable for connection to all types of fully pumped systems provided that the constant water flow through the boiler is not affected by manual or automatic operation of controls within the system. Protection against pump failure must be provided, eg; by the fitting of a water flow switch. A suitable switch can be obtained from Ideal Commercial Heating. The modular arrangement of the boiler and its high tolerance to condensation allows for efficient control of heat output without the use of mixing valves.

Operation should be at constant volume flow rate with 11°C (20°F) temperature difference across boiler and system.

General guidance on system layouts are shown in the diagrams (see Figures 2, 3 and 4).

Figure 2 is intended as a GUIDE ONLY with the following assumptions and conditions applying:

- Open vent and cold feed connections are made to the boiler flow and return manifolds respectively.
- The pump is positioned on the flow. The water velocity is assumed to be below 1.5m/s (5ft/s) and the volume flow rate to be 1.07 l/s (14.1 gal/m - Super Series 4) or 2.15 l/s (28.4 gal/m - Super Plus) per boiler module.
- In an existing system a filter/strainer should be positioned into the common return pipework to prevent debris entering the heat exchangers.

Note:

- Single module boiler requirements are as for multi-module boilers.
- Hydraulic resistance for all Super Series 4 boilers is 125 mbar (50 in.w.g.) or Super Plus boilers is 98 mbar (39 in.w.g.) at the design flow rate.
- Minimum tank height dimensions shown may have to be increased to comply with pump manufacturer's requirements to avoid cavitation. It may also be necessary to consider the requirements of Guidance. Note: PM5, issued by the Health & Safety Executive. Refer also to the Installation Instructions.
- Mixing headers should be sized at 1 standard pipe size larger than the common flow and return pipework.
- Super Series 4: 2000mm (79 in.), Super Plus: 1600mm (63 in.).

Figure 4:

Example 1 shows an application with independent boiler primary pumps based on 11°C (20°F) temperature difference across boiler. Boiler primary pumps (dual sets) are rated at 4.28 l/s (56.4 gal/m) against 125 mbar (50 in.w.g - Super Series 4) or 8.6 l/s (113.8 gal/m) against 98 mbar (39 in.w.g - Super Plus) plus pipework resistance. Example 2 shows an application with common boiler primary pump based on an 11°C (20°F) temperature difference across the boiler. Boiler primary pump (dual set) is rated at 8.56 l/s (112.8 gal/m) against 125 mbar (50 in.w.g - Super Series 4) or 17.2 l/s (227.6 gal/m) against 98 mbar (39 in.w.g - Super Plus) plus pipework resistance. Note: In both cases modules should be switched on each boiler simultaneously to give a variety of turndown ratios. Boiler primary pumps must run at all times, irrespective of the number of modules firing on either boiler.

Figure 2: Simple combined heating and DHW System

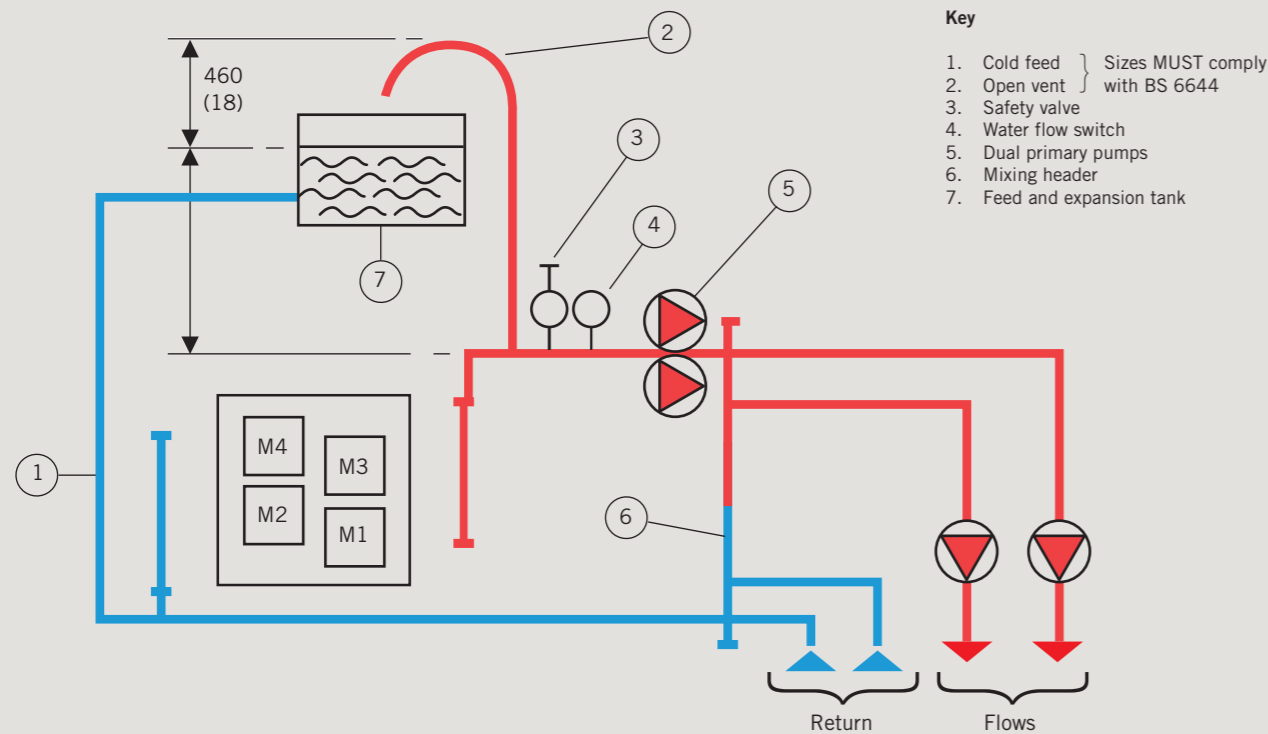
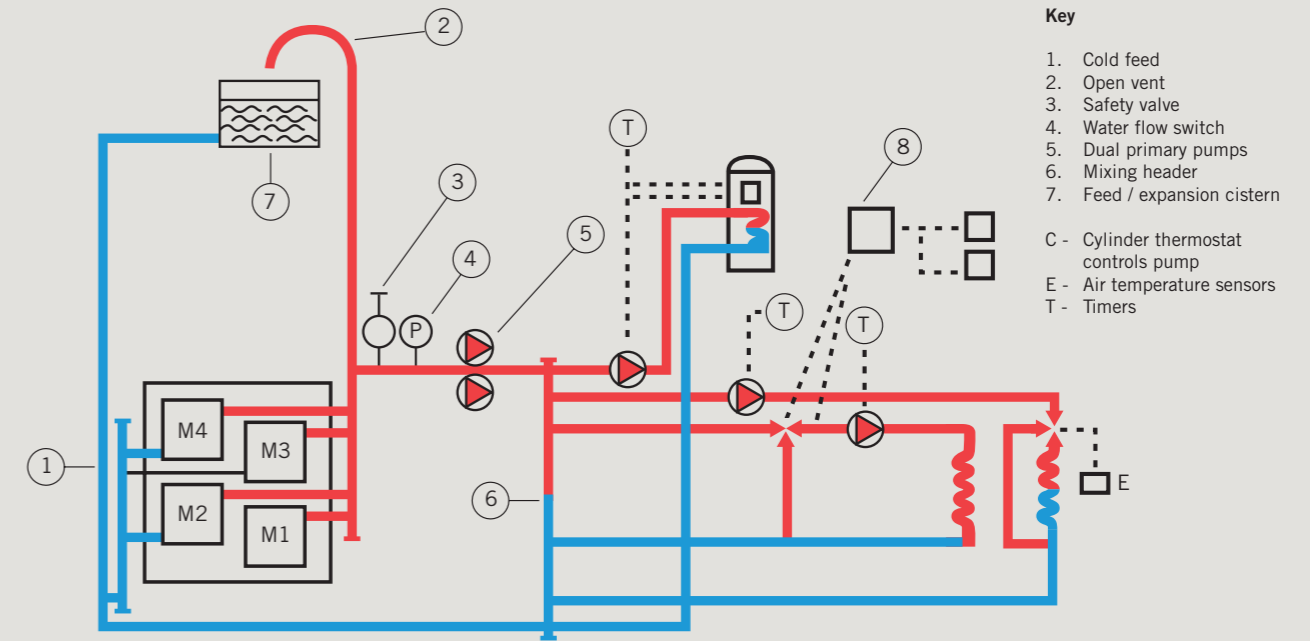

Figure 3: Example of multi-zone heating and DHW System connected to multi-module boiler



Note:

**Super Series 4**

The primary pump is 1.07 l/s x 4 modules and 4.28 l/s (56.6 gal/m) against 125 mbar (50 in. w.g.) plus pipework resistance.

**Super Plus**

The primary pump is 2.15 l/s x 4 modules and 8.6 l/s (113.8 gal/m) against 98 mbar (39 in. w.g.) plus pipework resistance.

Figure 4: Example of multi-zone heating and DHW System connected to two multi-module boilers

Example 1

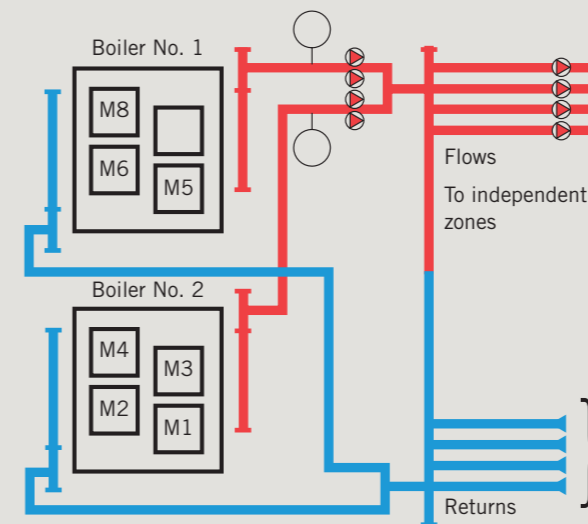

Example 2

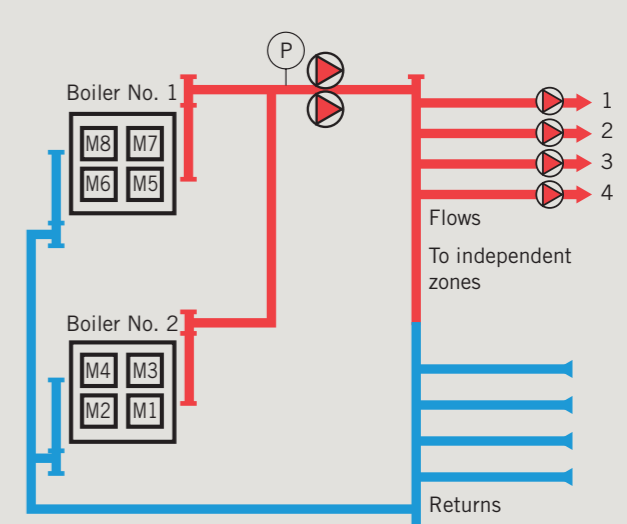

Open vents, cold feed and safety valves OMITTED for clarity.

## The Ideal Commercial Heating product range

Boiler output	kW	20	40	100	150	200	600	800	1000	1500	3500
	Btu/h (000)	68	136	340	511	682	2047	2729	3412	5118	11942
<b>Atmospheric Boilers</b>											
Concord CXA/H			40-120								
Concord CXS/H			40-120								
Concord CXSi/H				110-180							
Concord ESi				140-380							
Concord Modular				80-720							
<b>High Efficiency Boilers</b>											
Concord Super Series 4			50-600								
Concord Super Plus				200-600							
<b>Condensing Boilers</b>											
Evomax		30-150									
Evomod				250-1000							
Imax plus III				95-330							
Imax xtra				80-560							
<b>Pressure Jet Boilers</b>											
Buccaneer GTE	21-39										
Falcon GTS		40-100									
Harrier GTS				105-330							
Viceroy GTS					300-780						
Viscount GTS							754-1450				
Vanguard L							130-3500				

### Approval

These appliances are certified to G.A.D. 90/396 and B.E.D. 92/42 Safety and Performance Directives for gas boilers.

Ideal Commercial Heating pursues a policy of continuous improvement in design and performance of its products and reserves the right to vary specification without notice. Statutory rights of the consumer are not affected.

### Please note:

The information in this brochure was correct at the time of going to print.

Ideal Commercial Heating reserve the right to make any modifications to product specifications or any other details, without prior notification. For further clarification, please enquire in writing to the head office address on the reverse of this brochure.

## Ideal Service & Support

At Ideal Commercial Heating, we are committed towards delivering the highest levels of customer service. With over a century of experience in the heating industry, we know how important confidence and trust is to our customers.

You can be confident to know that you're partnering with a British manufacturer that's supported by a dedicated national service team, delivering help and advice to you and your customers throughout the year.

Our rigorous research and development procedures and manufacturing quality control checks, ensures that all of our products are produced to the highest standards; delivering total comfort and peace of mind.

The call centre team, based in Hull, East Yorkshire, is comprehensively trained to provide tailored advice. All calls will be answered by trained members of staff who will take ownership of the call. All of our trained staff are on-hand to assist with enquiries or help diagnose and resolve faults over the telephone. Should that not be possible, we will arrange an appointment for one of our engineers to visit. Our dedicated team of engineers are fully trained to exacting standards and are all Gas Safe registered.

### Ideal Commercial Heating Service

#### Sales

Tel: 01482 498690  
Fax: 01482 498299

#### Technical

Tel: 01482 498376  
Fax: 01482 498621

#### Training

Tel: 01482 498432  
Fax: 01482 498605

[commercial\\_services@idealheating.com](mailto:commercial_services@idealheating.com)



## Training at Ideal Heating



Here at Ideal, we understand that having the confidence to be able to specify and install a wide range of products is an essential part of your day-to-day job.

With this in mind, we have created a wide range of comprehensive training courses, utilising both classroom and hands-on learning techniques to enable you to become a more efficient, skilled heating engineer.

All of our training courses have been designed to ensure that you get the most out of the time spent off the road and can be easily adapted to suit the desired knowledge level. So, if you're looking to refresh your existing knowledge, or to learn how to install something completely new, Ideal Heating has a course for you.

### Commercial Boiler Training Courses

1 and 2 days

#### Courses are available on the following products:

- Evomax range (1 day)
- Evomod range (1 day)
- Imax range (2 days - Hull only)
- Concord CX range (2 days - Hull only)
- Concord Super range (2 days - Hull only)

These comprehensive one-day courses can be mixed and matched for individual installation and servicing companies. The courses use a simple step-by-step approach with hands on training to ensure all aspects of commissioning, servicing, and fault finding can be dealt with quickly and efficiently.

Each course covers the following:

- Product range overview
- Product specification
- Application and installation of products
- Electronic circuits and components
- Flue and accessory options
- Component overview, change and repair
- User controls
- Sequence of operation
- Fault finding
- Commissioning

The course involves discussion with tutors and demonstrations with practical advice. Lunch and refreshments are provided and a certificate is awarded upon completion.

**Price £80.00 for 1 day**

(including VAT) per person

**Price £160.00 for 2 days**

(including VAT) per person

## Ideal Commercial Heating

---

P.O. Box 103  
National Avenue  
Kingston Upon Hull  
HU5 4JN

**T: 01482 492251**

**F: 01482 448858**

[www.idealcommercialheating.com](http://www.idealcommercialheating.com)

