

users guide

imax plus III

Your Ideal users guide

See reverse for **i**max plus III installation & servicing guide

**Models F95, F145, F190
& F235, F285, F330**

When replacing any part on this appliance, use only spare parts that you can be assured conform to the safety and performance specification that we require. Do not use reconditioned or copy parts that have not been clearly authorised by Ideal Boilers.

i BOILERS *Ideal*
The High Efficiency Pioneers

Contents

INDICE

1 Symbols used in this guide	2
2 Correct use of the appliance	2
3 Water treatment	2
4 Information to be passed over to the person in charge of the appliance	3
5 Safety warnings	3
6 Operating instructions	4
6.1 Other possible information	20
6.2 Introduction of access code	20
6.3 Displaying of error codes	21
7 QUICK GUIDE	22

1 - SYMBOLS USED IN THIS GUIDE

When reading this guide particular care has to be given to the parts marked with the followings symbols:



DANGER!
Indicates serious danger
for your personal safety
and for your life



WARNING!
Indicates a potentially dangerous
situation for the product and the
environment



NOTE!
Suggestions for the
user

2. - CORRECT USE OF THE APPLIANCE



The Imax Plus appliance has been designed utilizing today's heating technology and in compliance with the current safety regulations. However, following an improper use, dangers could arise for the safety and life of the user or of other people, or damage could be caused to the appliance or other objects. The appliance is designed to be used in pumped hot water central heating systems. Any other use of this appliance will be considered improper. Ideal Boilers declines any responsibility for any damage or injuries caused by an improper use; in this case the risk is completely at the user's responsibility. In order to use the appliance according to the scopes it was designed for it is essential to carefully follow the instructions indicated in this guide.

3 - WATER TREATMENT



- The Imax Plus III boiler has an Aluminium alloy heat exchanger.
- Ideal Boilers strongly recommends the system is thoroughly cleaned prior to the use of a suitable inhibitor.
- For further details see section 3.17.

4 - INFORMATION TO BE HANDED OVER TO THE USER



The user has to be instructed on the use and operation of his heating system, in particular:

- Hand over these instructions to the end user, together with any other literature regarding this appliance, placed inside the envelope contained in the packaging. **The user has to keep these documents in a safe place in order to always have them at hand for future reference.**
- Inform the user on the importance of air vents and of the flue outlet system, stressing the fact that is absolutely forbidden to make any alterations to the boiler.
- Inform the user how to check the system's water pressure as well as informing him how to restore the correct pressure.
- Explain the function of time and temperature controls, thermostats, heating controls and radiators, to ensure the greatest possible fuel economy.
- Remind the user that the appliance should be serviced annually by a Gas Safe Registered Engineer or in IE by a competent person.
- If the appliance is sold or transferred to another owner or if the present user moves home and leaves the appliance installed, ensure yourself that the manual always follows the appliance so that it can be consulted by the new owner and/or installer.

Failure to follow the instructions indicated in this guide, which is supplied with the boiler, could cause injury to persons, animals or damage to property. The manufacturer shall not be held liable for any such injury and/or damage.

5 - SAFETY WARNINGS



WARNING!

The installation, adjustment, and servicing of this appliance must be carried out by a competent person and installed in accordance with the current standards and regulations. Failure to correctly install this appliance could cause injury to persons, animals or damage to property. The manufacturer shall not be held liable for any such injury and/or damage.



DANGER!

NEVER try to service or repair the appliance yourself.

All types of servicing or repairs must be carried out by a Gas Safe Registered Engineer or in IE by a competent person. Ideal Boilers recommends drawing up a service contract. Bad or irregular servicing could compromise the safe operation of the appliance, and could cause injury to persons, animals or damage to property for which Ideal Boilers shall not be held liable.



Modifications to parts connected to the appliance

Do not carry out any modifications to the following parts:

- the boiler
- to the gas, air, water supply pipes and electrical current
- to the flue pipe, safety relief valve and its drainage pipe
- to the constructive components which influence the appliance's safe operation



Smell of gas

If you smell gas follow these safety indications:

- Do not turn on or off electrical switches
- Do no smoke
- Do not use the telephone
- Close the On/Off gas cock
- Open all windows and doors where the gas leakage has occurred
- Inform the gas society or a specialized company



Explosive and easily inflammable substances

Do not use or leave explosive or easily inflammable material (as for example: petrol, paint, paper) in the room where the appliance has been installed.

Operating instructions

6 - AREAS AND LEVELS DESCRIPTION FOR THE HEATING CONTROLLER E8

For additional information refer to the instruction manual delivered with the E8 heating controller

AREAS

General

Value selection summary
Service => for service engineers
Date/Time/Holiday => for users

Display

System value display (e.g. sensor values and setpoints). No adjustments can be made. Operating errors are therefore excluded in this area.

User

Summary of settings that can be made by the operator.

Time programs

Summary of time programs for heating circuits, the hot water circuit and extra functions where applicable

Expert

Summary of values for which expert knowledge is required to make settings (installation technician). E Values in the expert level are protected by a code no. (damage/malfunction possible).

Expert FA (only for FA via BUS)

Summary of values transmitted by the automatic firing device.

LEVELS

The settings in the different areas are sorted into operating levels

- INSTALLATION
- HOT WATER
- HEATING CIRCUIT I
- HEATING CIRCUIT II
- SOLAR/MF

Installation

All display values and settings that relate to the heat generator or the entire system and cannot be assigned to a consumer circuit.

Hot water All display values and settings that affect central hot water preparation and circulation.

Heating circuit I / II

All indicator and set values that relate to the corresponding consumer circuit (also, for example, as decentral hot-water circuit).

Solar/MF

All indicator and set values that relate to solar energy recovery and settings for the multifunction relay.

	General	SERVICE DATA/HOUR/HOLIDAY
Open operating Flap	turn anticlockwise	
	turn clockwise	
	Display	INSTALLATION HOT WATER HEAT CIRCUIT I HEAT CIRCUIT II SOLAR/MF
	User	INSTALLATION HOT WATER HEAT CIRCUIT I HEAT CIRCUIT II SOLAR/MF
	Time programs	CIRCL TIME HOTW-PROGR HOTW-PROGR I ₁ etc
	Expert	INSTALLATION HOT WATER HEAT CIRCUIT I HEAT CIRCUIT II SOLAR/MF
		INSTALLATION

Parameter change procedures

Select the AREA with the searching Knob



The parameter to be changed is displayed

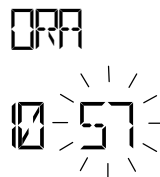

Go to the next parameter to be changed, with the searching knob, and repeat the a.m. procedure.

Once the AREA is reached, e.g. LATE HOUR depress the programming button



Change the parameter value with the searching knob



Depress the programming button, the red led lights



Depress the push button to record the parameter value (the led switches off)



Operating instructions



When the operating flap is first opened after voltage is applied, the level **INSTALLATION** is displayed once only. Once the values grouped here have been set the controller is operable.



Warning:
In the following tables are shown the factory set parameters. For additional information refer to the E8 instruction manual supplied with the boiler.



Set the parameters:
ENGLISH, HOUR, YEAR, MONTH, DAY.

BUS - ID HS has to be left blank _ _

The remaining parameters are already set.

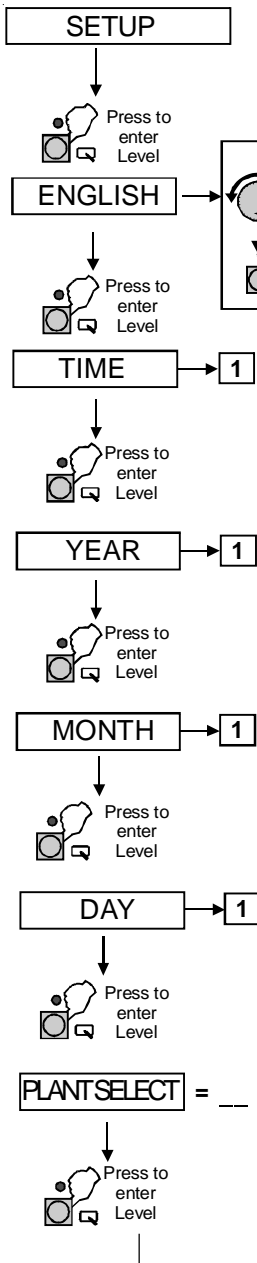

	Imax Plus E8 master	Imax Plus E8 slave
BUS-ID HS =	---	01 - 08
HS 1 TYPE =	06	06
HS 1 BUS =	02	02
HS 2 TYPE =	00	00
STORAGE Hs2 =	00	00
BUFFER TYPE =	00	00
HC FUNCTION 1 =	00	00
HC FUNCTION 2 =	00	00
CAP/MODULE =	"SCAN"	"SCAN"
RELAY FUNC 1 =	00	00
T-MF 1 SETP =	30.0	30.0
MF 1 HYST =	5.0	5.0
RELAY FUNC 2 =	00	00
T-MF 2 SETP =	30.0	30.0
MF 2 HYST =	5.0	5.0
RELAY FUNC 3 =	01	01
T-MF 3 SETP =	30.0	30.0
MF 3 HYST =	5.0	5.0
RELAY FUNC 4 =	02	02
T-MF 4 SETP =	30.0	30.0
MF 4 HYST =	5.0	5.0
BUS 1 ID =	01	---
BUS 2 ID =	---	---
5 K SENSOR =	00	00

Press 'Enter'
02 = 2 Stage (Not used)
01 = 50 (kW)
Continue until all are set
02 = 50
03 = 50 etc.
until Return reached.
Press 'Enter' to access the
next parameter screen

Operating instructions

Description AREAS: GENERAL



Area GENERAL it contain 2 area:
DATA/TIME and SERVICE.

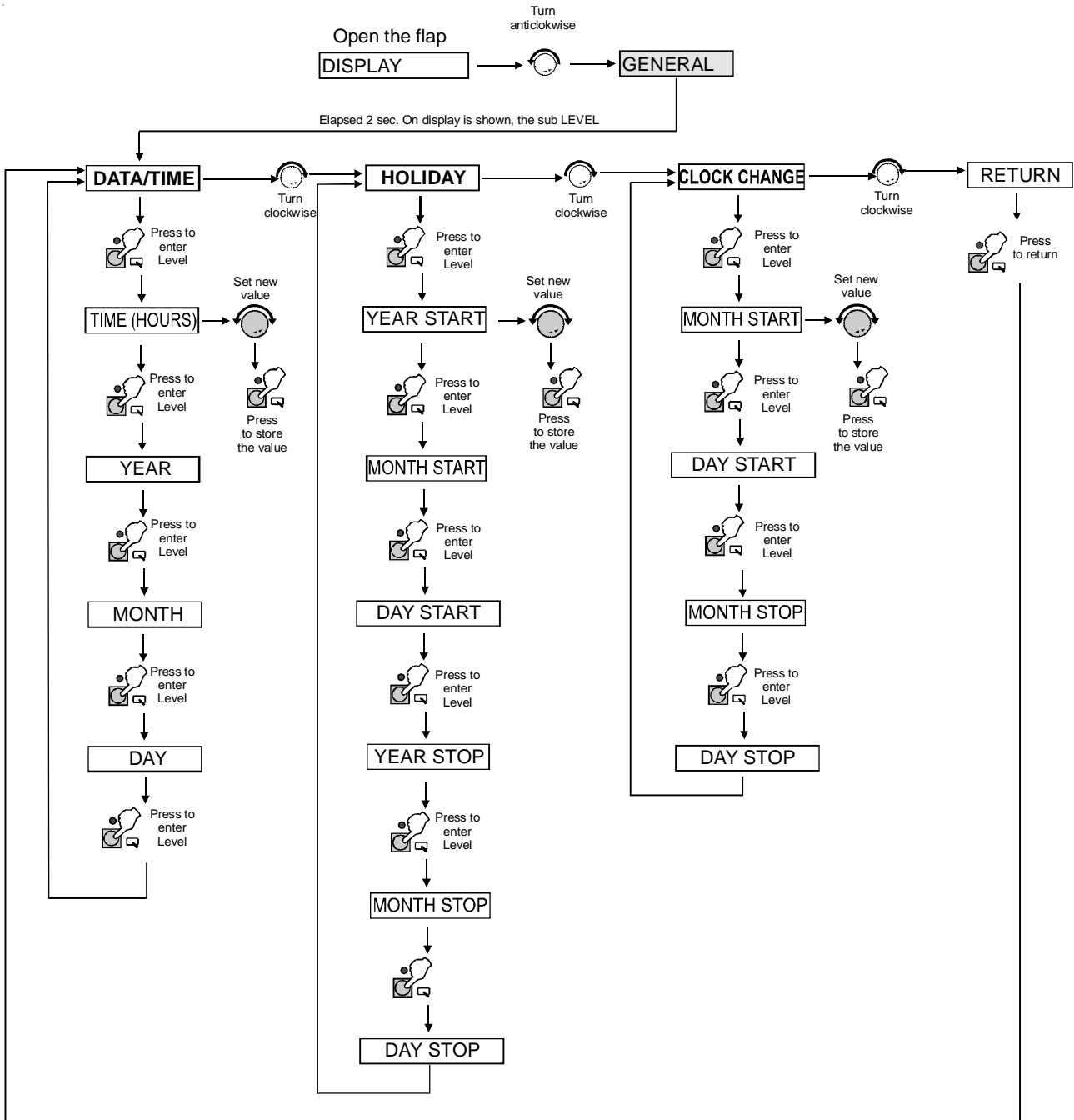

(*) Only place on the symbol with the flap CLOSED.

AREA GENERAL

LEVEL	DESCRIPTION	REGULATION
DATE/TIME		
TIME (HOURS)	Current hours blink and can be adjusted	00:00 - 24:00
YEAR	Adjust current year	XXXX
MONTH	Adjust current month	01 - 12
DAY	Adjust current day	01 - 31
HOLIDAY		
YEAR START	Set current holliday start year	XXXX
MONTH START	Set current holliday start month	01 - 12
DAY START	Set current holliday start day	01 - 31
YEAR STOP	Set current holliday end year	XXXX
MONTH STOP	Set current holliday end year	12 - 31
DAY STOP	Set current holliday end day	01 - 31
CLOCK CHANGE		
MONTH START	Set month for start of summer time	01 - 12
DAY START	Set earliest day for start of summer time	01 - 31
MONTH STOP	Set month for start of winter time	12 - 31
DAY STOP	Set earliest day for start of winter time	01 - 31

Operating instructions

Description AREAS: SERVICE

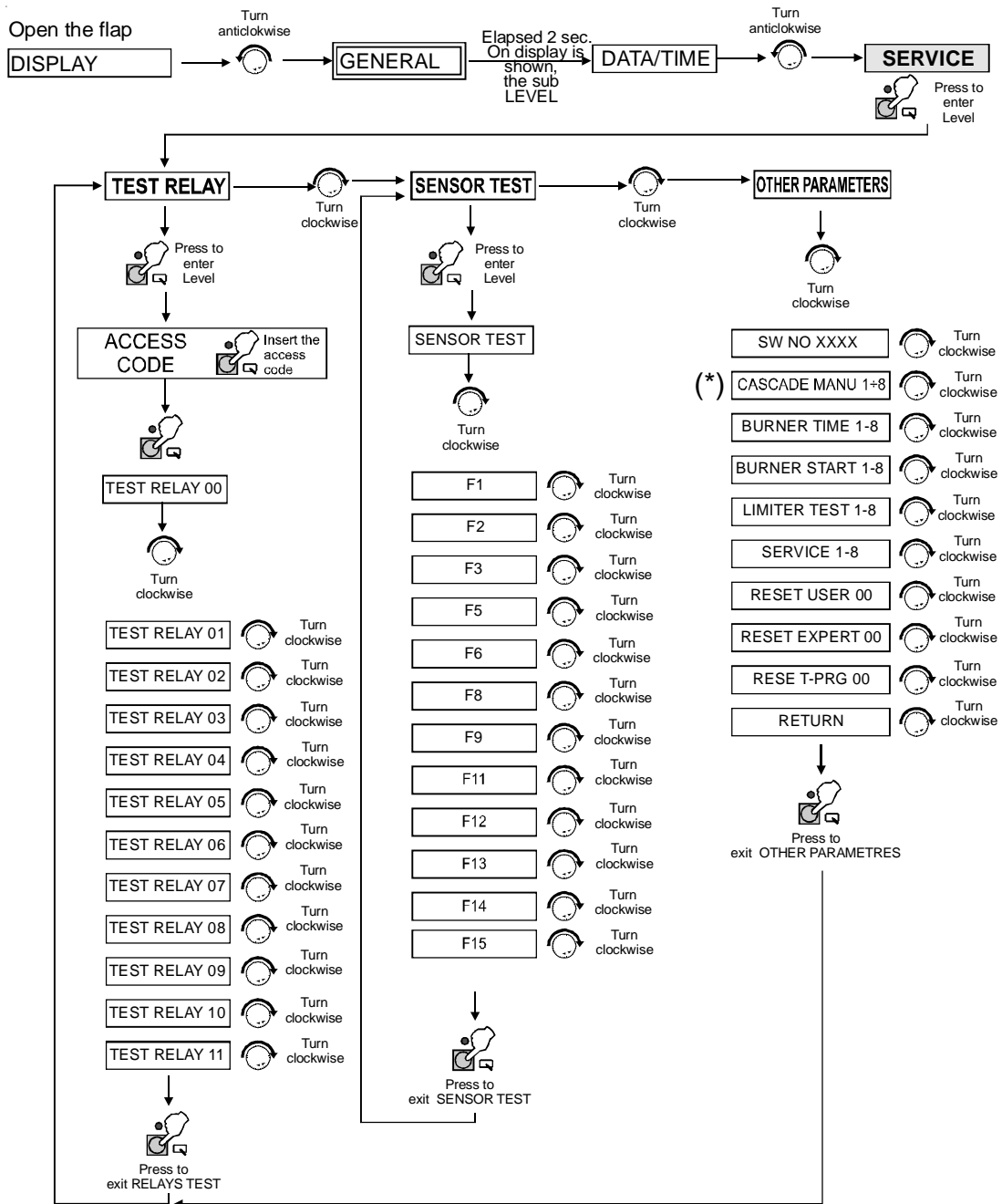

NOTE: Some menus are visible only if the relevant sensor is wired.
 E.g. HOT WATER is displayed only if the DHW storage sensor is wired.

AREA SERVICE

LEVEL	DESCRIPTION
TEST RELAYS	Boiler in stand-by mode
RELAY TEST 00	No relay
RELAY TEST 01	A1: Pump heating circuit 1
RELAY TEST 02	A2: Pump heating circuit 2
RELAY TEST 03	A3: Hot water charging pump
RELAY TEST 04	A4: Mixer OPEN heating circuit 2
RELAY TEST 05	A5: Mixer CLOSED heating circuit 2
RELAY TEST 06	A6: Heat Source 1 ON
RELAY TEST 07	A7: Heat Source 2 ON [2 stage: HS 1+2 (after 10s) ON]
RELAY TEST 08	A8: Mixer OPEN heating circuit 1 / Multifunction 1
RELAY TEST 09	A9: Mixer CLOSED heating circuit 1 / Multifunction 2
RELAY TEST 10	A10: Multifunction 3
RELAY TEST 11	A11: Collector pump / Multifunction 4
SENSOR TEST	
F1	Buffer storage temperature Lower
F2	Buffer storage temperature Middle or room temperature heating circuit 1
F3	Upper buffer storage temperature
F5	Flow temperature heating circuit 2
F6	Upper hot water temperature
F8	Boiler/Header temperature
F9	Outside temperature
F11	Flow temperature heating circuit 1 or temperature multifunction 1
F12	Hot water temperature lower or temperature multifunction 2
F13	Solid fuel boiler temperature or collector 2 or temperature multifunction 3
F14	Collector 1 temperature or temperature multifunction 4
F15	Room temperature heating circuit 2 or measured value of the lighth sensor or voltage value 0-10V input
OTHER PARAMETERS	
SW NO XXX-XX	Software number with index
CASCADE MANU	Starting different burner stages of the cascade
BURNER TIME (1-8)	burner time for all stages
BURNER START (1-8)	burner start for all stages
LIMITER TEST (1-8)	Safety temperature limiter test: press the botton hold down
SERVICE	Date/Hour setting for service purposes
RESET USER 00	do not use
RESET EXPERT 00	do not use
RESET T-PRG 00	do not use
RETURN	

AREAS DISPLAY

LEVEL	DESCRIPTION
INSTALLATION	
T-OUTSIDE	Outside temperature
T-EXT DES	External set value specification (0-10 V)
T-COLL DES	HS / Header set value (cascade)
T-COLLECTOR	HS / Header temperature (cascade)
T-BOIL	Temperature and status of the HS (HS1 - HS8)
T-SOLID FUEL	For HS2 = Solid fuel boiler
T-RETURN 1	Return flow temperature of HS 1
T-RETURN 2	Return flow temperature of HS 2
T-BUFFER T	Buffer storage tank temperature: top position
T-BUFFER M	Buffer storage tank temperature: middle position
T-BUFFER L	Buffer storage tank temperature: lower position
T-STORAGE 3	Temperature of storage tank 3 (e.g. solar pool-heating)
MODGRAD	Modulation level for hetch modul
RETURN	
HOT-WATER	
T-DHW RATED	Hot water set temperature value
T-DHW	Hot water temperature value
T-DHW L	Hot water temperature in infeed area
T-CIRC	Recirculating temperature
RETURN	
HTG CIRCUITC 1/2	
T-ROOM DES A	Current value for set room temperature
T-ROOM	Room temperature
HUMIDITY	Display of room humidity (if value is available)
T-POOL DES	Pool set temperature
T-POOL	Pool temperature
T-DHW RATED	Hot water set temperature value
T-DHW	Hot water temperature value
T-FLOW RATED	Current flow temperature setting
T-FLOW	Current flow temperature
N-OPT-TIME	Display of the time last required for heating-up
RETURN	
SOLAR / MF	
T-MF1	Temperature MF sensor 1 (=F11)
T-MF2	Temperature MF sensor 2 (=F12)
T-MF3	Temperature MF sensor 3 (=F13)
T-MF4	Temperature MF sensor 4 (=F14)
T-COLLECTOR	Temperature collector 1
T-DHW	Upper hot water temperature
T-DHW L	Hot water temperature infeed
RETURN	



Warning:
For additional informations refer to the E8 instruction manual supplied with the boiler.

Operating instructions

Description AREAS: **USER**

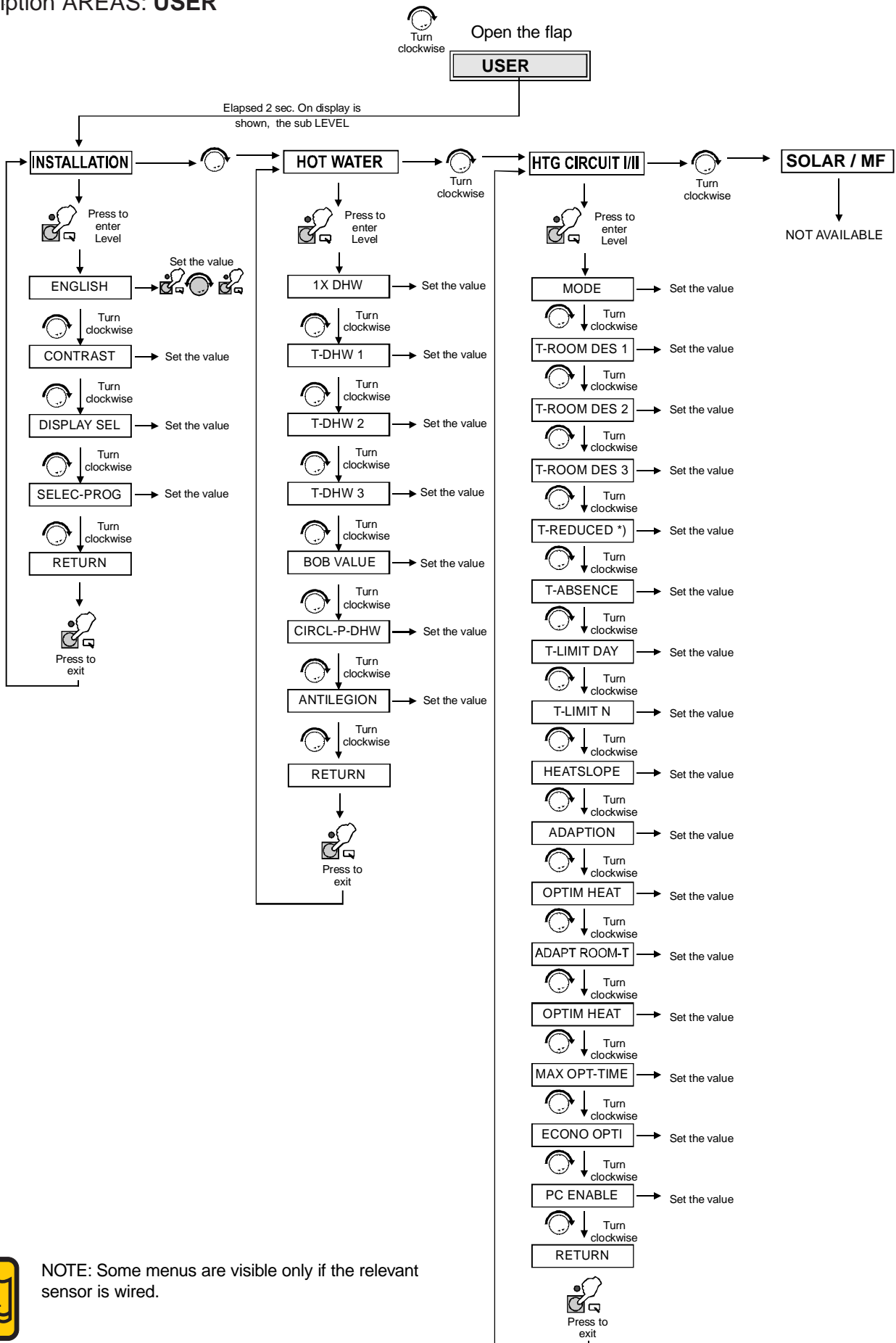

NOTE: Some menus are visible only if the relevant sensor is wired.

AREAS USER

LEVEL	DESCRIPTION	REGULATION	
		Set	Range
INSTALLATION		Set	Range
ENGLISH	According to version	ENG	
CONTRAST	Adjust intensity of display	00	(-20) / (20)
DISPLAY SEL	Select additional display in standard operation	----	
SELEC-PROG	Heating circuit 1 or Heating circuit 2	01	(01 - 02)
RETURN			
HOT WATER			
1-DHW	If set the value 01 => the boiler switch on immediatly	00	(01 - 02)
T-DHW 1	Hot water temperature setting in first enable time	60	(10 - 70)
T-DHW 2	Hot water temperature setting in second enable time	60	(10 - 70)
T-DHW 3	Hot water temperature setting in third enable time	60	(10 - 70)
BOB VALUE	Operation without burner (solar or solid fuel integration)	0	(0 - 70)
CIRCL-P-DHW	Ig set the value 01 => the circulation pump runs when the hot water is enable, but the circulation program is disabled	0	(0 - 1)
ANTILEGION	If the value 01 => every 20th time that heating takes place or once per week on Saturday at 01:00 hrs the storage tank is heated up to 149 °F	0	(0 - 1)
RETURN			
HTG CIRCUIT 1/2			
MODE	When setting an alternative operating mode this only applies to the assigned heating circuit	-----	
T-ROOM DES 1	Room temperature setting in first enable time	20	(5 - 40)
T-ROOM DES 2	Room temperature setting in second enable time	20	(5 - 40)
T-ROOM DES 3	Room temperature setting in third enable time	20	(5 - 40)
T REDUCED	Required room temperature setting during night reduction	10	(5 - 40)
T-ABSENCE	Required room temperature setting during holidays	15	(5 - 40)
T-LIMIT DAY	Set the temperature value during heating time	19	(-5 - 40)
T-LIMIT N	Set the temperature value during reduction time	10	(-5 - 40)
HEATSLOPE	Set the Heatslope according to the installation	1,20	(0 - 3)
ADAPTION	Only active if an FBR analogue room device is connected and an outdoor sensor	0	(0 - 1)
OPTIM HEAT	Activation of function for automatically bringing forward the start of heating	10	(0-20)
ADAP ROOM-T	Room sensor adaptation	0	(5K--5K)
OPTIM HEAT	Heating optimisation	0	(00 - 02)
MAX OPT-TIME	The start of heating is brought forward by no more than this time	2	(00 - 03)
ECONO OPTI	Automatic reduction of burner disabling to the end of set heating time	0	(00 - 02)
PC-ENABLE	Code number for enabling access to heating circuit data from a PC (0000= access is blocked)	0000	(0000-9999)
SOLAR / MF			
RETURN	NOT USED		

Operating instructions

Description AREAS: TIME PROGRAM

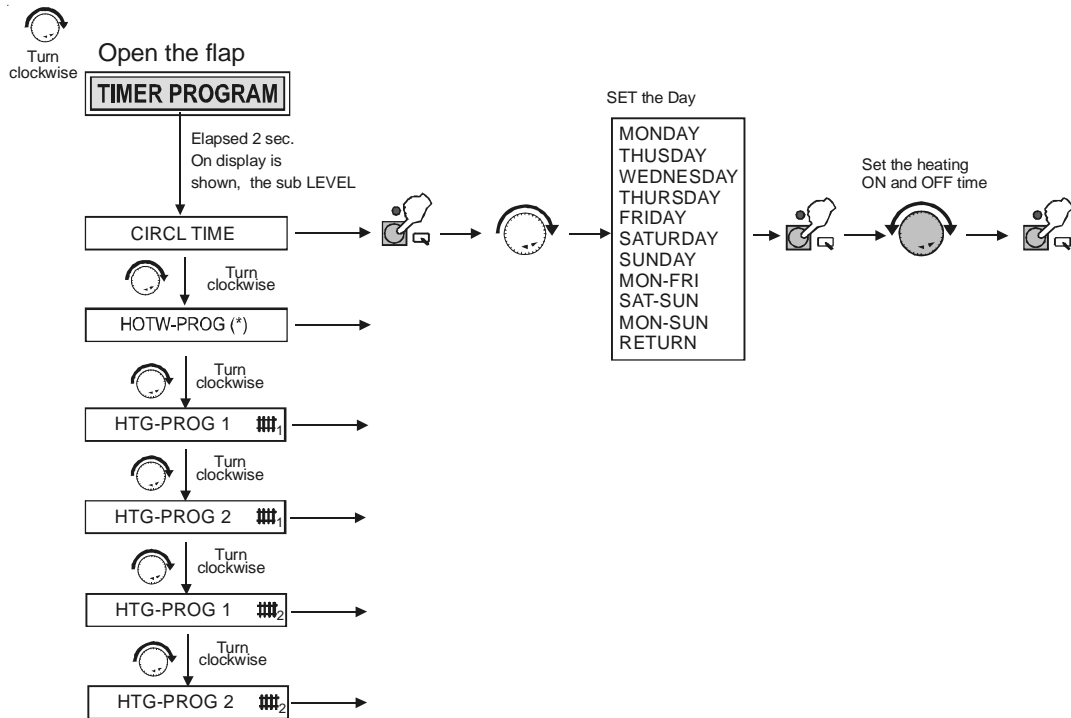

By leaving the hour _ _ : _ _ the heating period is bypassed

CIRCL TIME	Prg for circulation pump
HOTW-PROG (*)	Prg for hot water charging pump
HTG-PROG 1	1st Heating program for first controller heating circuit
HTG-PROG 2	2nd Heating program for first controller heating circuit
HTG-PROG 1	1st Heating program for second controller heating circuit
HTG-PROG 2	2nd Heating program for second controller heating circuit

(*) Active only with parameter 1 x HW = 00



NOTE: Some menus are visible only if the relevant sensor is wired.

Description AREAS: EXPERT

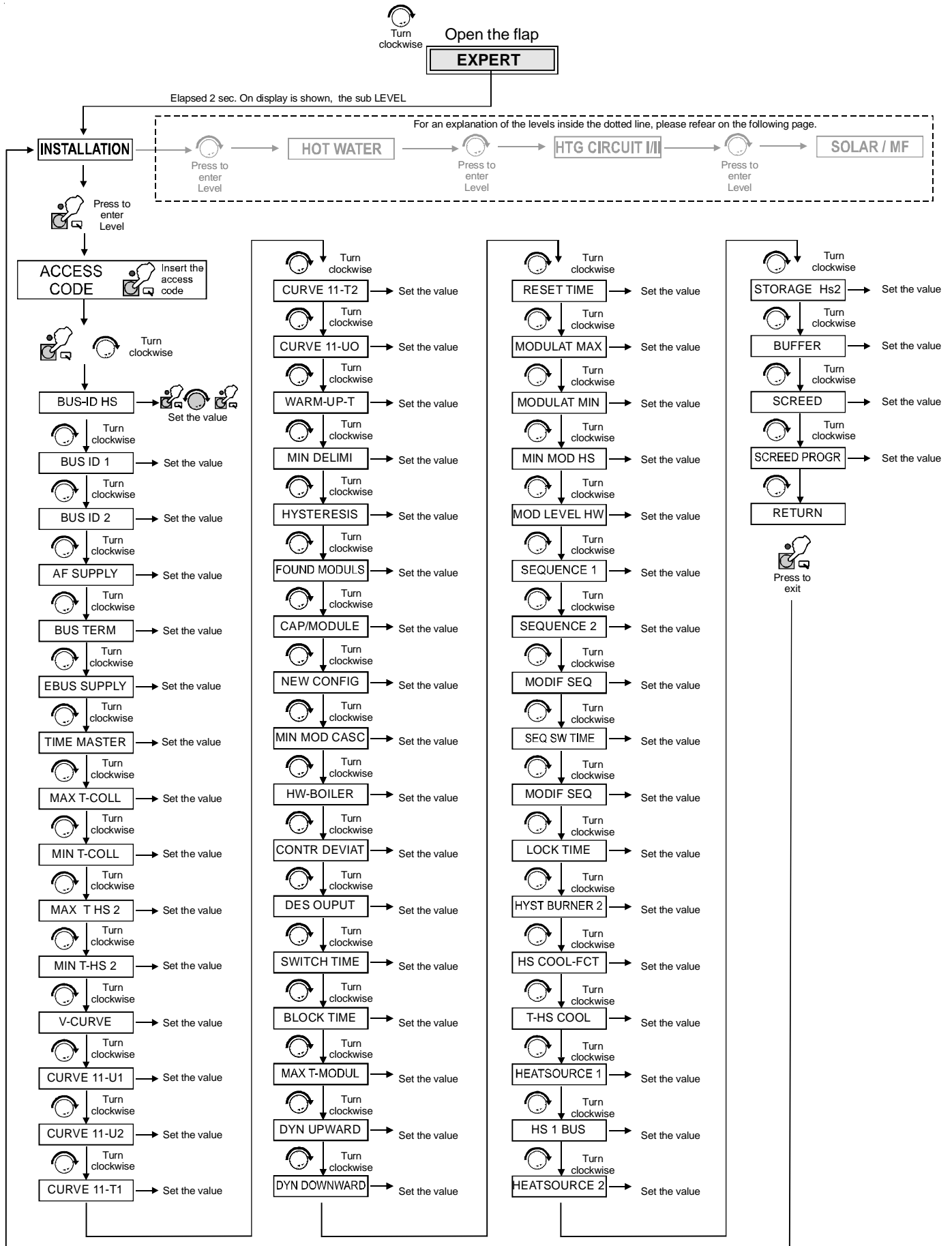

Operating instructions



Open the flap

EXPERT

For an explanation of the levels inside the dotted line, please refer on the following page.

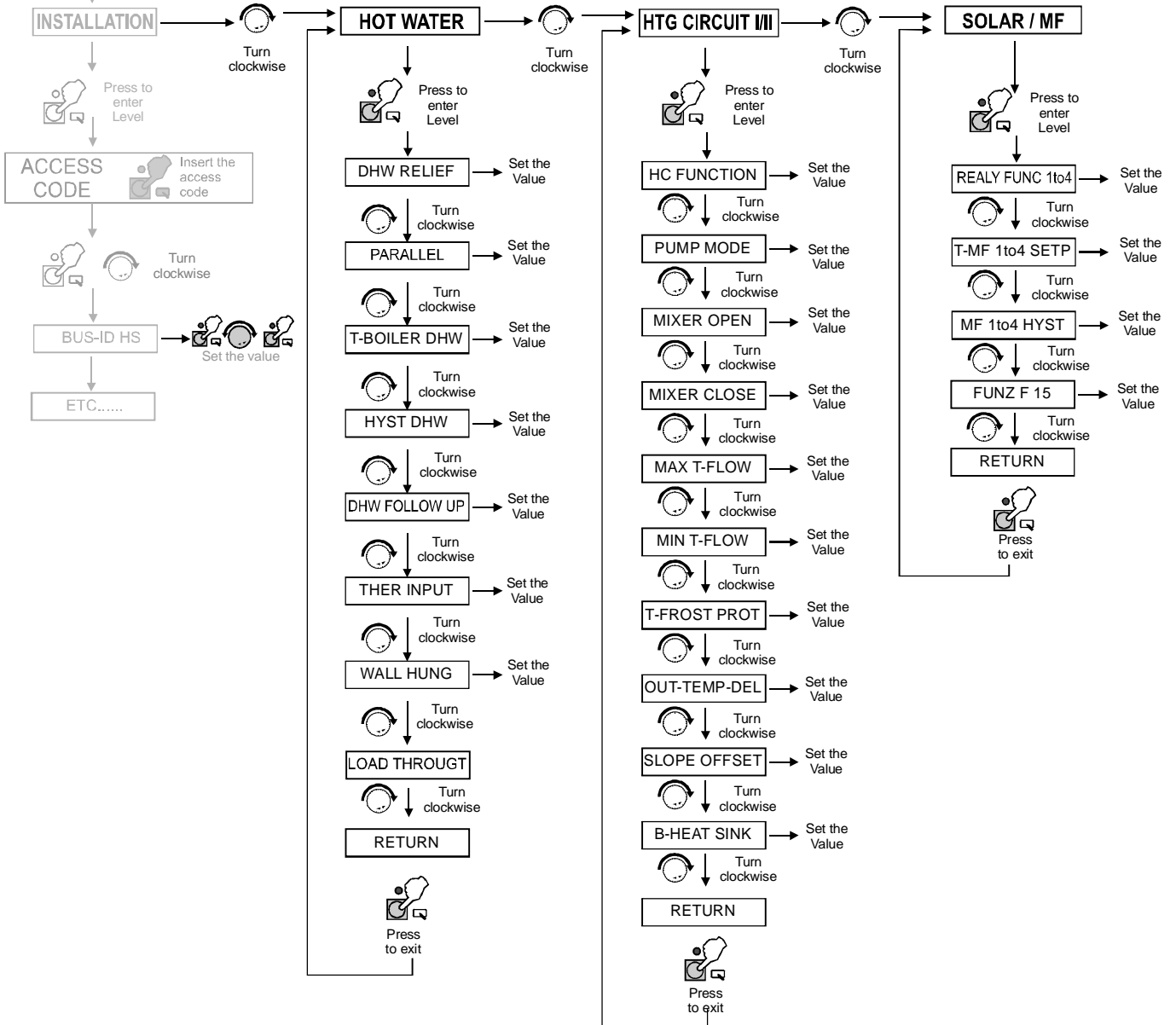

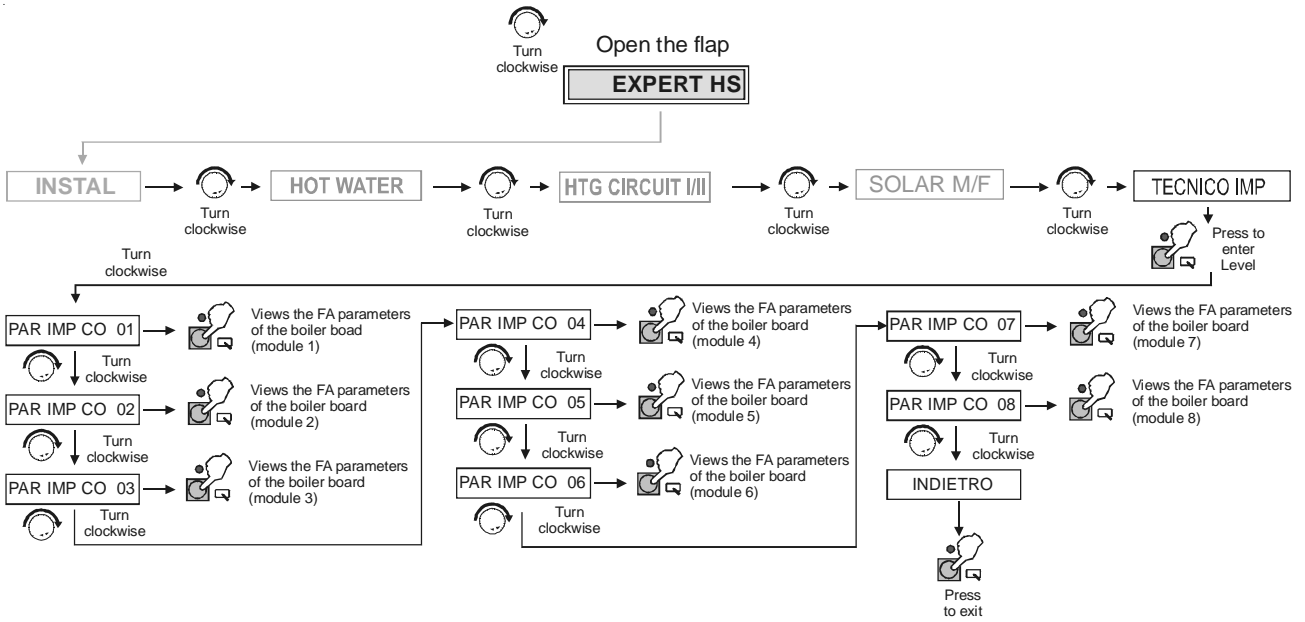

PAR IMP CO:

01 - 02 - 03 - 04 - 05 - 06 - 07 - 08 :

FAN MOD IGN
FAN MOD STBY
FAN MAX
FAN MIN
MAX DIFF PRO
MIN FLOW PRO
MIN FLOW RAT
BOIL HYS
BOIL SLP LIM
BOIL P VAL
BOIL I VAL
BOIL D VAL
PUMP OVERRUN
PUMP MIN MOD
CAP FLOW RATE
FAN P VAL
FAN I VAL
FAN SLP
FAN SLP POS
FAN SLP NEG
FAN START PW
FAN ADAPT
RESTARTS
SW NO
SW RWV

Operating instructions

AREA EXPERT:

LEVEL	DESCRIPTION	REGULATION	
		Set	Range
INSTALLAZ			
BUS-ID HS	Boiler Bus address only for cascade of E8 controllers	----	(01 - 08)
BUS ID 1	The heating circuits are sequentially numbered.....	01	(01 - 15)
BUS ID 2	The heating circuits are sequentially numbered.....	--	(01 - 15)
AF SUPPLY	Outdoor sensor power supply	01	(01 - 15)
BUS TERM	Bus terminating resistor	01	(00 - 01)
EBUS SUPPLY	Switching eBUS supply on/off in realtion to connected	01	(00 - 01)
TIME MASTER	00 no time master; 01 controller is time master	00	(01 - 01)
MAX T-COLL	Protects the HS from overheating	85°C	(30 - 110)
MIN T-COLL	Decreased condensation build-up in HS with low heat requirem.	10°C	(10 - 80)
MAX T-HS2	Protects the HS from overheating	85°C	(30 - 110)
MIN T-HS2	Decreased condensation build-up in HS with low heat requirem.	10°C	(10 - 80)
V-CURVE	Only for 0-10V input/output	11°C	(00 - 11)
CURVE 11 - U1	Low voltage set	1 V	(0 V-10 V)
CURVE 11 - U2	High voltage set	10 V	(0 V-10 V)
CURVE 11 - T1	Low temperature level	20°C	(0 - 120)
CURVE 11 - T2	High temperature level	85°C	(0 - 120)
CURVE 11 - UO	Starting with this voltage level	2 V	(0 V-10 V)
WARM-UP-T	Warm-up relief	35°C	(10 - 85)
MIN-DELIMI	Minimum delimiter HS	0	(01 - 03)
HYSTERESIS	Dyn. Switching hysteresys stage 1	5	(2K - 20K)
FOUND MODULS	Display of heat generators automatically reported via BUS	0	(0-30 min)
CAP/MODULE	After restarting the controller searches the bus systems	----	(0-1000)
NEW CONFIG	If the BUS configuration was modified, the automatic ..		(00 - 01)
MIN MOD CASC	When the casacade is started the number of stages.....	0	(00 - 100)
HW-BOILER	Number of stages for HW operation	0	(00 - 08)
CONTR DEVIAT	Header control variance		(00 - 08)
DES OUPUT	Required system output [in %]		(0 - 100)
SWITCH TIME	Internal control value: only for switching cascade		(-99 - 99)
BLOCK TIME	Currently remaining value		
MAX T-MODUL	Maximum temperature of the heat generator	90°C	(50 - 110)
DYN UPWARD	Dynamic heat generator connection	300	(20 - 500)
DYN DOWNWARD	Dynamic heat generator deactivation	200	(20 - 500)
RESET TIME	Resetting time for I-Controller	50	(5 - 500)
IMODULAT MAX	If this modulation degree is exceeded, the next heat	30	(5 - 100)
MODULAT MIN	If values drop this modulation degree, the last heat	35	(10 - 60)
IND MOD MIN	Connection of the next heat generator	35	(0 - 60)
MOD LEVEL HW	Entry of the set modulation degree for the heat generators	80	(40 - 100)
SEQUENCE 1	Boiler sequence 1		12345678
SEQUENCE 2	Boiler sequence 2		87654321
MODIF SEQ	Sequence change mode	06	(01 - 06)
SEQ SW TIME	Time to sequence change	200	(10 - 800)
LOCK TIME	Min. delay time after switching on or with switching HS	00	(00 - 30)
HYST BURNER2	Solid fuel integration: hysteresiys for the charging pump	2	(2 - 20)
HS COOL-FCT	not used	0	(0 - 1)
T-HS COOL	not used	80	(50 - 95)
HEATSOURCE 1	Primary heat generator type	06/02	(00 - 06)
HS 1 BUS	connections for HS	02/03	(00 - 04)

AREA EXPERT:

LEVEL	DESCRIPTION	REGULATION	
		Set	Range
INSTALLATION			
HEATCOURSE 2	secondary heat generator type	0	(00 - 05)
STORAGE HS 2	heat accumulator for HS2	0	(00 - 03)
BUFFER	heater buffer storage tank	0	(00 - 03)
SCREED	activation of screed drying process	0	(00 - 01)
SCREED PROGR	program setting		
RETURN			
HOT-WATER			
DHW RELIEF	The charging pump is not switched until.....	0	(00 - 01)
PARALLEL	Pump parallel running	0	(00 - 03)
T-BOILER DHW	Boiler temperature setting with hot water preparation	20	(00 - 50)
HYST DHW	Hot water hysteresys	5	(5 - 30)
DHW FOLLOWUP	Pump run-down time	0	(00 - 30)
THER INPUT	Storage tank with thermostat	0	(00 - 01)
WALL HUNG	Boiler temperature setting with hot water preparation	0	(00 - 01)
LOAD THROUGH	The charge through function can be activated by...	0	(00 - 01)
RETURN			
HTG CIRCUIT 1/2			
HC FUNCTION	heating circuit function selection	0	(00 - 04)
PUMP MODE	Pump operating mode	02	(00 - 03)
MIXER OPEN	Open mixer dynamic	18	(5 - 25)
MIXER CLOSE	Close mixer dynamic	12	(5 - 25)
MAX T-FLOW	max flow temperature setting	80	(20 - 110)
MIN T-FLOW	min flow temperature setting	10	(10 - 110)
T-FROST PROT	frost protection temperature	0	(-15 - -5)
OUT-TEMP-DEL	outside temperature delay	0	(0 - 24)
SLOPE OFFSET	Heating slope distance	5	(0 - 50)
B-HEAT SINK	Circuit enable	0	(00 - 01)
RETURN			
SOLAR / MF			
REALY FUNC 1 to 4	Function selection relay 1 to 4	--	(00 - 26)
T-MF1 to 4 SETP	Switching temperature relay MF1 to 4	30	(30 - 90)
MF 1 to 4 HYST	Hysteresys relay MF1 to 4	5	(2 - 10)
FUNZ. F15	Sensor function F15	0	(00 - 02)
RETURN			



NOTE:

The parameters on shaded AREAS of the previous page change according to the boiler type and the use as single or in cascade boiler.



Warning:

For additional informations refer to the E8 instruction manual supplied with the boiler.



NOTE: Some menus are visible only if the relevant sensor is wired.

Operating instructions

6.1 OTHER POSSIBLE SETTINGS

Settings for heating circuit 1 \ 2

Heating adjustment with constant flow temperature (without outer sensor)

It offers the possibility to have a constant flow temperature on the selected heating circuit.

⇒ HC FUNC "01"

For additional informations refer to the E8 instruction manual supplied with the boiler.

temperature Settings for heating circuits (Only after function selection)

User Area ⇒ Heating circuit I / II ⇒ FLOW TEMP DAY

User Area ⇒ Heating circuit I / II ⇒ FLOW TEMP NIGHT

A second DHW storage tank (Only after function selection)

It offers the possibility to use one of the heating zone for the preparation of a second DHW storage tank

Expert area ⇒ Heating circuit I/II ⇒ HC FUNC. "03"

For additional informations refer to the E8 instruction manual supplied with the boiler.

Temperature setting for second DHW storage tank

User AREA ⇒ Heating circuit / II ⇒ T- HW

Swimming pool

It offers the possibility to use one of the heating zone for the heating of a swimming pool

Wires the pool temperature sensor to connector (III 1+2)

Expert area ⇒ Heating circuit I/II ⇒ HC FUNC "02"

(For additional informations refer to the E8 instruction manual supplied with the boiler.

Swimming pool temperature setting (Only after function selection)

User Area ⇒ Heating circuit I / II ⇒ T- POOL 1 / 2 / 3

Screed dry programm (floor heating installation)

Setting of a program for drying the screed

Expert area ⇒ Installation ⇒ SCREED "01"

For additional informations refer to the E8 instruction manual supplied with the boiler.

Temperature setting for screed program

User Area ⇒ Heating circuit I / II

Signal 0 – 10 V

Inlet of 0-10 V signal for slope control trough en outer regulator (connect F15)

Expert area ⇒ Solar/MF ⇒ FUNC. F15 "01"

For additional informations refer to the E8 instruction manual supplied with the boiler.

Slope and temperature setting with 0 – 10 V signal

Expert Area ⇒ Installation ⇒ TENS SLOPE (0 to 11)

Expert Area ⇒ Installation ⇒ SLOPE 11 – XX (freely settable)

N°	U1	U2	T1	T2	UA
0	2,0	10,0	0	90	2,0
1	2,5	0,3	38	80	5,0
2	2,5	0,3	38	75	5,0
3	2,5	0,3	38	45	5,0
4	4,0	0,1	20	85	5,0
5	4,0	0,1	20	75	5,0
6	4,0	0,1	20	55	5,0
7	4,0	0,1	30	87	5,0
8	4,0	0,1	38	87	5,0
9	4,0	0,1	38	73	5,0
10	4,0	0,1	38	53	5,0
11	4,0	0,1	20	90	5,0

U1 = Volt min

U2 = Volt max

T1 = T min (volt min)

T2 = T max (volt max)

UA = Off

(U = tension;

T = temperature;

1 = Min;

2 = Max;

UA = Off;)

Setting of DHW circuit

Operation of pumps in parallel

Possibiliti to keep in operation the heating pumps also during DHW production.

Expert area ⇒ Hot water ⇒ F-PUMP PARAL "00,01,02,03"

For additional informations refer to the E8 instruction manual supplied with the boiler.

Use of a DHW storage tank thermostat (on/off)

It is possible to use an ON - OFF thermostat instead of DHW sensor

Expert area ⇒ Hot water ⇒ THER INPUT "01"

For additional informations refer to the E8 instruction manual supplied with the boiler.

Antilegion

Activation of an antilegion program

Expert area ⇒ Hot water ⇒ ANTILEGION "01"

For additional informations refer to the E8 instruction manual supplied with the boiler.

Setting for solar panel use

Use as solar panel sensor a PT 1000 sensor

Expert area ⇒ Solar/ MF ⇒ FUNC RELAY 4 "23"

For additional informations refer to the E8 instruction manual supplied with the boiler.

6.2 ACCESS CODE SETTING



Depress the programming push button to set the access code



NOTE:
To modify or to display some parameters is necessary to set the access code

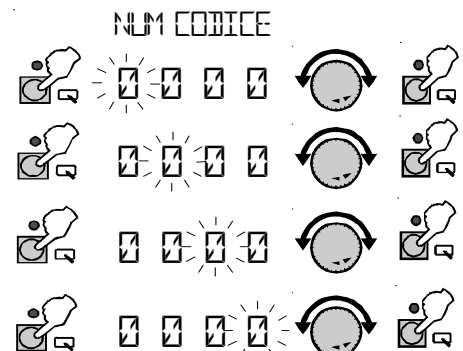

6.3 - DISPLAY OF ERROR CODES ON HEATING CONTROLLER E8

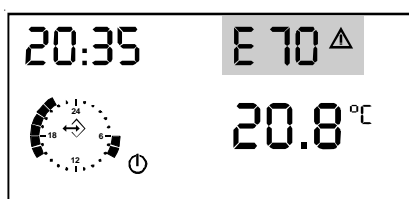

If a fault or error occurs in the heating system a blinking warning triangle and the related error code will appear on the E8 display.

Here below are listed the boiler's error codes, relative meanings and corrective actions.

For the error codes relative to the heating system please refer to the paragraph "Fault finding" in the "Users guide" supplied together with the heating controller E8.5064 V1.

Cod: **Significato:**

E1	Intervention of the high limit thermostat(TL)	E30	Alteration of the operating parameters caused by EMC disturbances
E2	Insufficient gas pressure	E32	Mains supply voltage < 190 Vac
E4	No flame detected during the ignition phase.	E69	E8: F5 – Flow temperature sensor heating circuit 2
E5	Loss of flame signal during boiler operation	E70	E8: F11 – Flow temperature sensor heating circuit 1
E6	Over high water temperature detected by the heating sensor (SR) (>95°C)	E71	E8: F1 – Lower storage temperature sensor (Buffer)
E10	Internal failure of the local control PCB (BMM)	E72	E8: F3 – Higher storage temperature sensor (Buffer)
E11	Flame signal detected before the ignition cycle	E75	E8: F9 – Outer temperature sensor (AF)
E12	Heating sensor failure (SR)	E76	E8: F6 – DHW storage temperature sensor (SPF)
E13	DHW sensor failure (only if the boiler is combined with an external storage tank)	E78	E8: F8 – Boiler temperature sensor (KF)
E14	Failure of the heating return sensor (SRR)	E80	E8: F2 – Room temperature sensor heating circuit 1
E15	Difference between the global return heating temperature global sensor and the heating flow sensor > 30°C (rp +10).	E81	E8: EEPROM fault. The invalid value has been replaced by the standard value
E16	Boiler body temperature very low: Ice forming risk	E83	E8: F15 – Room temperature sensor heating circuit 2
E20	Flame signal detected after burner OFF	E90	E8: BUS addresses 0 and 1. The BUS codes 0 and 1 cannot be used at the same time.
E22	The air pressure switch doesn't change over within 30 s from starting of the burner ignition cycle	E91	E8: BUS code occupied. The set BUS code is already used by another appliance
E23	Air pressure switch contact always closed	E99	E8: Internal failure
E24	Modulating fan speed failure: it doesn't reach the correct speed within 30 s from starting of burner ignition cycle	E135	E8: F12 – Lower DHW storage temperature sensor MF2
E26	Modulating fan speed failure: it doesn't stop within 30 s from end of operation	E136	E8: F13 – Boiler 2, Manifold 2 MF 3
E27	Air pressure switch detects an anomaly during the burner ignition cycle.	E137	E8: F14 – Manifold 1, Multifunction 4.
		E200	E8: Intervention os safety devices (fans rotating at maximum speed) / communication error module 1
		E201	E8: communication error module 2
		E203	E8: communication error module 3
		E204	E8: communication error module 4
		E205	E8: communication error module 5
		E206	E8: communication error module 6
		E207	E8: communication error module 7

7

QUICK GUIDE

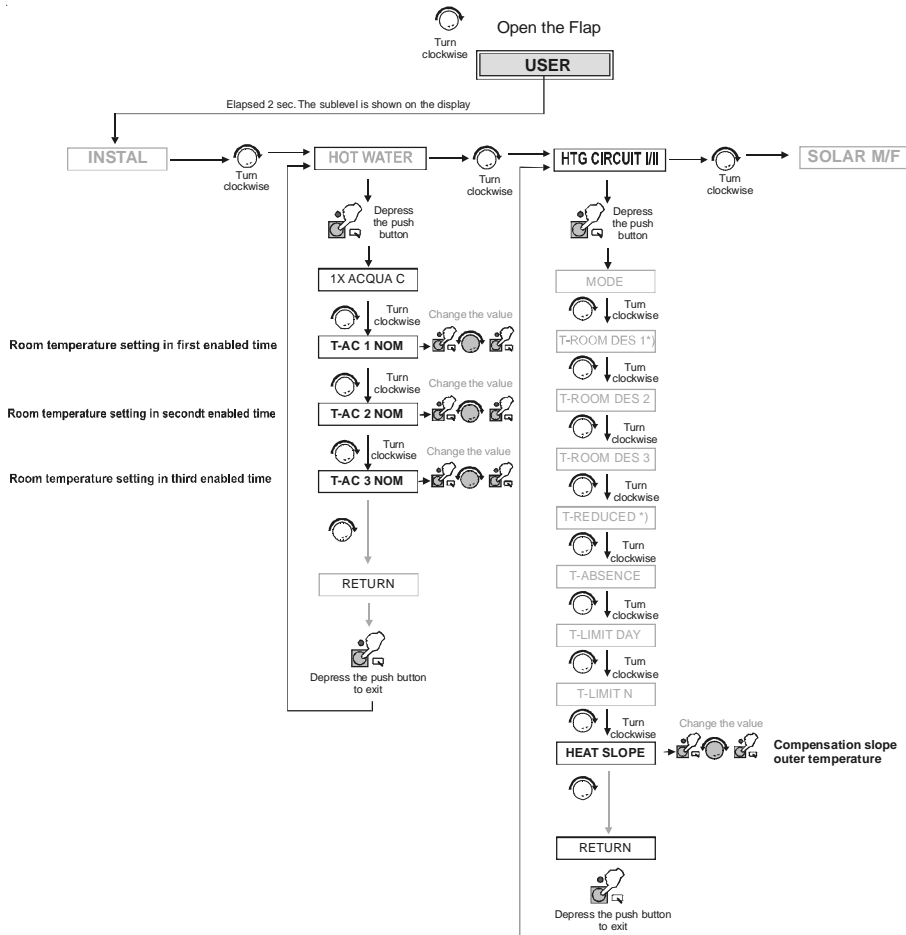
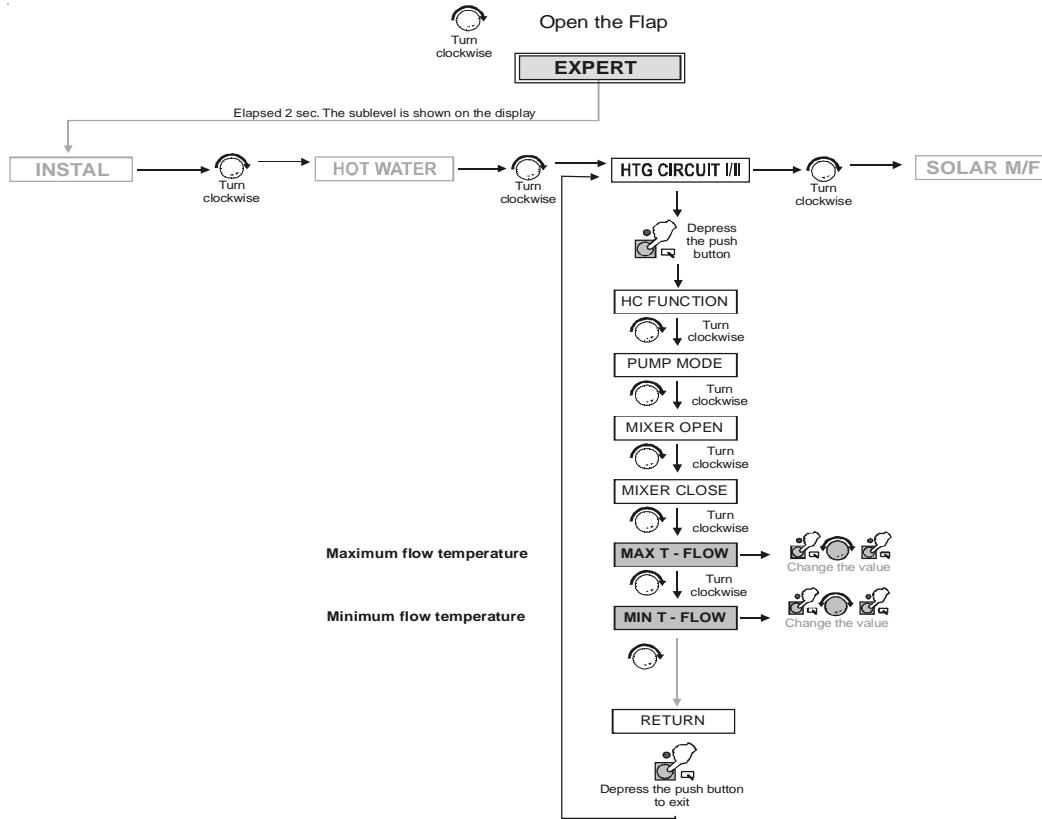

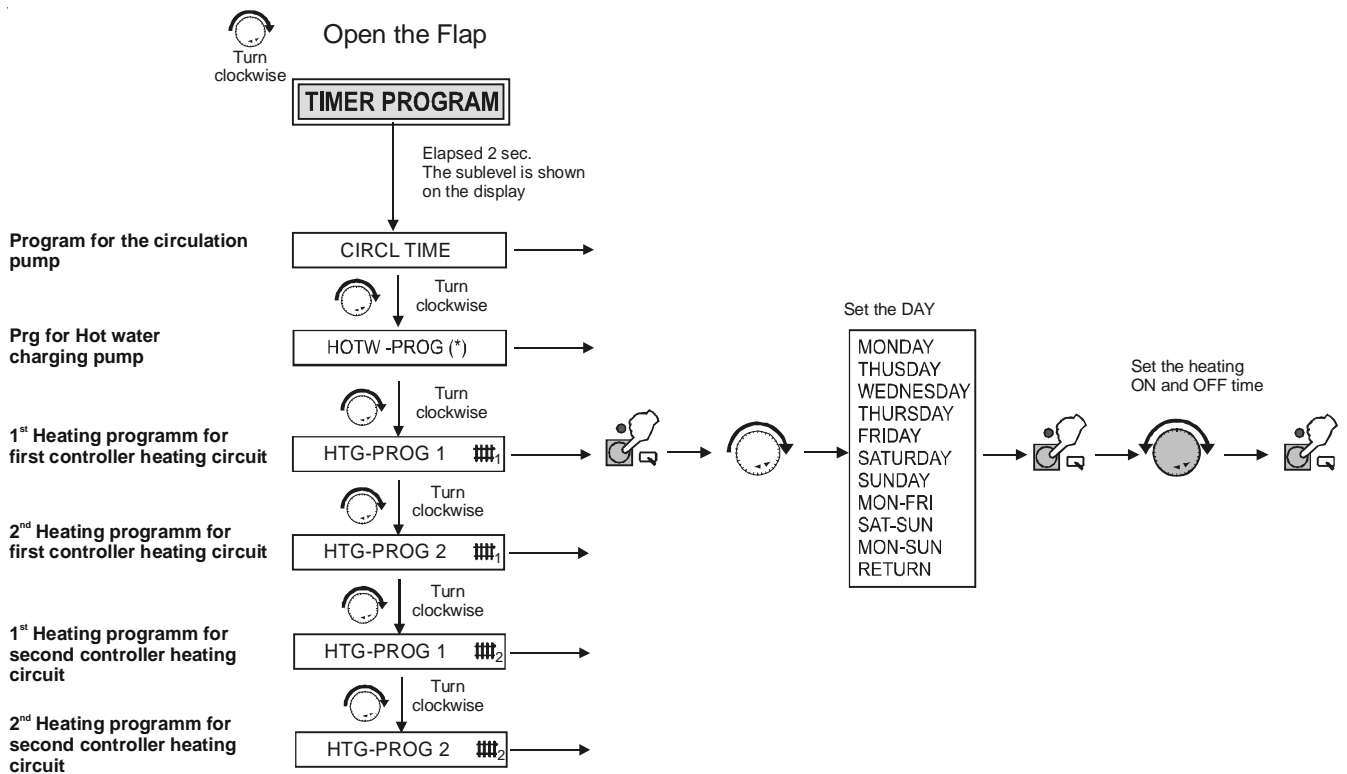
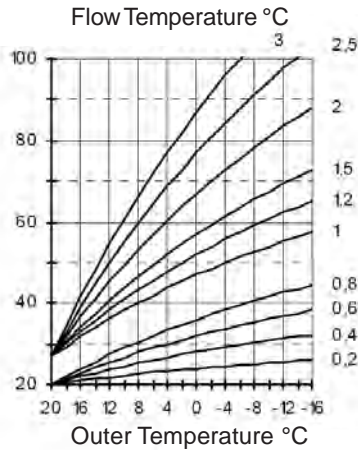

Notes:

1. This instruction manual does not replace the one supplied with the E8 heating controller, but is an integration with intended to simplify the operations and the comprehension.
2. For the electrical wiring make always reference to the boiler installation and servicing instructions
3. This instruction manual doesn't make any reference to a specific model of boiler, but to a series of products which use the same E8 heating controller
4. This model of E8 heating controller is used on different types of boiler; it is therefore necessary to always verify the boiler model on which it is use in order to select the most convenient setting.



Ideal Consumer Helpline
Tel: 01482 498376
www.idealboilers.com

Ideal Stelrad Group pursues a policy of continuing improvement in the design and performance of its products. The right is therefore reserved to vary specification without notice.

Ideal Boilers, P.O. Box 103, National Ave, Kingston Upon Hull, HU5 4JN. Tel. 01482 492251 Fax. 01482 448858. Registration No. London 322 137.

