

INSTALLATION AND SERVICING

VANGUARD L

170, 240, 290, 340, 420, 510, 630, 760,
870, 970, 1100, 1320, 1570, 1850, 2200,
2650, 3000, 3500

When replacing any part on this appliance, use only spare parts that you can be assured conform to the safety and performance specification that we require. Do not use reconditioned or copy parts that have not been clearly authorised by Ideal.

For the very latest copy of literature for specification and maintenance practices visit our website www.idealheating.com where you can download the relevant information in PDF format.



GENERAL

Table 1 Performance Data

Boiler Size		170	240	290	340	420	510	630	760	870	970	1100	1320	1570	1850	2200	2650	3000	3500
Maximum Heat Output	kW	170	240	290	340	420	510	630	760	870	970	1100	1320	1570	1850	2200	2650	3000	3500
	Btu/hx10 ³	580	819	990	1160	1433	1740	2150	2593	2969	3301	3753	4504	5357	6312	7507	9042	10236	11942
Minimum Heat Output	kW	130	180	220	255	315	385	480	580	660	750	860	1000	1200	1400	1700	2000	2300	2700
	Btu/hx10 ³	444	614	751	870	1075	1314	1638	1980	2252	2559	2934	3412	4095	4777	5800	6824	7848	9212
Hydraulic resistance 11K	mbar	27.5	60.4	38.4	51.2	31.1	45.8	69.5	47.6	60.4	75.0	54.9	64.1	60.4	82.4	62.2	87.9	113.5	153.7
	in wg	11.0	24.2	15.4	20.5	12.4	18.3	27.8	19.0	24.2	30.0	22.0	25.6	24.2	32.9	24.9	35.1	45.4	61.5
Hydraulic resistance 20K	mbar	8.3	18.3	11.6	15.5	9.4	13.8	21.0	14.4	18.3	22.7	16.6	19.4	18.3	24.9	18.8	26.6	34.3	46.5
	in wg	3.3	7.3	4.7	6.2	3.8	5.5	8.4	5.8	7.3	9.1	6.6	7.8	7.3	10.0	7.5	10.6	13.7	18.6
Combustion chamber resistance (at zero draught)	mm w.g.	15	28	25	34	29	43	55	51	57	49	52	67	60	73	65	76	60	74
	in w.g.	0.59	1.10	0.98	1.34	1.14	1.69	2.17	2.01	2.24	1.93	2.05	2.64	2.36	2.87	2.56	2.99	2.36	2.91
Flow connection	(T1) DN PN16	65	65	80	80	100	100	100	125	125	125	150	150	175	175	200	200	200	200
Return connection	(T2) DN PN16	65	65	80	80	100	100	100	125	125	125	150	150	175	175	200	200	200	200
Max. operating pressure	bar	6	6	6	6	6	6	6	6	6	6	6	6	6	6	6	6	6	6
Max. boiler therm. setting	°C	60-90	60-90	60-90	60-90	60-90	60-90	60-90	60-90	60-90	60-90	60-90	60-90	60-90	60-90	60-90	60-90	60-90	60-90
Safety thermostat setting	°C	100	100	100	100	100	100	100	100	100	100	100	100	100	100	100	100	100	100
High-low setting	°C	54-84	54-84	54-84	54-84	54-84	54-84	54-84	54-84	54-84	54-84	54-84	54-84	54-84	54-84	54-84	54-84	54-84	54-84
Min. draught at smokehood outlet (for max. output)	mbar	0.0	0.0	0.0	0.0	0.0	0.0	0.0	0.0	0.0	0.0	0.0	0.0	0.0	0.0	0.0	0.0	0.0	0.0
	in w.g.	0.0	0.0	0.0	0.0	0.0	0.0	0.0	0.0	0.0	0.0	0.0	0.0	0.0	0.0	0.0	0.0	0.0	0.0
Safety valve & expansion	(T3) BSP/DN PN6	1 1/2"	1 1/2"	2"	2"	2"	2"	2"	2"	65	65	65	80	80	100	100	125	125	125
Drain	(T4) in	3/4	3/4	3/4	3/4	3/4	3/4	3/4	1 1/4	1 1/4	1 1/4	1 1/2	1 1/2	1 1/2	1 1/2	1 1/2	1 1/2	1 1/2	1 1/2
Flue outlet	(T5) mm	200	200	250	250	250	250	300	350	350	350	400	400	450	450	520	520	570	620
	in	7.8	7.8	9.8	9.8	9.8	9.8	11.8	13.8	13.8	13.8	15.7	15.7	17.7	17.7	20.5	20.5	22.4	24.4
Boiler water content	l	190	251	264	298	398	462	565	671	753	836	1040	1242	1418	1617	2086	2324	2667	4142
	gal	41.8	55.2	58.1	65.6	87.5	101.6	124.3	147.6	165.6	183.9	228.8	273.2	311.9	355.7	458.9	511.2	586.7	911.1
Boiler DRY weight less burner unit	kg	435	510	588	629	796	919	1049	1341	1447	1553	1821	2030	2780	3280	4145	4465	5110	6700
	lb	959	1124	1296	1387	1755	2026	2313	2956	3190	3424	4015	4475	6129	7231	9138	9844	11266	14771

Table 2 Oil Firing Data

Boiler Size		170	240	290	340	420	510	630	760	870	970	1100	1320	1570	1850	2200	2650	3000	3500
Maximum oil rate	l/h	19.1	27.0	32.5	38.1	47.1	57.2	70.8	85.2	97.4	108.6	123.2	147.9	176.0	207.4	247.1	297.3	336.6	393.1
	gal/h	4.2	5.9	7.2	8.4	10.4	12.6	15.6	18.7	21.4	23.9	27.1	32.5	38.7	45.6	54.4	65.4	74.0	86.5
Maximum flue gas volume	m ³ /sec	0.10	0.14	0.17	0.20	0.25	0.31	0.37	0.44	0.52	0.56	0.64	0.76	0.91	1.07	1.26	1.52	1.72	1.99
	ft ³ /min	209	299	356	417	523	648	775	932	1102	1189	1348	1620	1926	2255	2670	3213	3638	4221
Flue Gas CO ₂ at 195°C	%	13.0	12.8	13.0	13.0	12.8	12.5	13.0	13.0	12.5	13.0	13.0	13.0	13.0	13.1	13.2	13.2	13.2	13.3

Table 3 Gas Firing Data

Boiler Size		170	240	290	340	420	510	630	760	870	970	1100	1320	1570	1850	2200	2650	3000	3500
Maximum Gas Rate Gross	m ³ /h	19.1	26.9	32.4	38.0	47.0	57.0	70.5	84.9	97.1	108.3	122.8	147.5	175.4	206.7	246.3	296.4	335.6	391.9
	ft ³ /h	673.2	949.4	1144.7	1340.6	1657.9	2013.1	2489.5	2996.7	3426.7	3820.6	4332.6	5204.8	6190.6	7294.6	8693.5	10460.4	11841.9	13830.5
Maximum flue gas volume	m ³ /sec	0.10	0.14	0.17	0.19	0.25	0.30	0.37	0.45	0.52	0.57	0.65	0.78	0.93	1.08	1.26	1.51	1.75	2.04
	ft ³ /min	211	293	360	411	519	633	775	946	1098	1211	1368	1657	1967	2299	2671	3203	3717	4332
Flue Gas CO ₂ at 195°C	%	10.0	10.1	10.0	10.2	9.9	9.9	10.2	9.9	9.8	10.0	10.0	10.0	10.0	10.1	10.2	10.2	10.2	10.2

Note.

Fuel rates and flue gas data relate to maximum output ratings. Gas firing data relates to the use of NATURAL GAS ONLY. Details for the use of LPG are available on request from Ideal. Natural gas consumption is calculated using a calorific value of 38.7MJ/m³ (1038Btu/ft³) gross or 34.9MJ/m³ (935Btu/ft³) nett at 15°C and 1013.25mbar.

HEALTH & SAFETY DOCUMENT NO. 635

The electricity at work regulations, 1989. The manufacturer's notes must NOT be taken, in any way, as overriding statutory obligations.

IMPORTANT. These appliances are CE certified for safety and performance. It is, therefore, important that no external control devices, e.g. flue dampers, economisers etc., are directly connected to these appliances unless covered by these Installation and Servicing Instructions or as otherwise recommended by **Ideal** in writing. If in doubt please enquire.

Any direct connection of a control device not approved by **Ideal** could invalidate the certification and the normal appliance warranty. It could also infringe the Gas Safety Regulations and the above regulations.

Assembly and Installation Instructions for Ideal Vanguard L heating boilers should be read in conjunction with the general technical data tables enclosed and any other technical publication supplied with the burner.

CONTENTS

Assembly.....	15-23
Boiler Clearances.....	9
Boiler Dimensions.....	6-8
Burner Connection.....	24
Commissioning and Testing.....	28 & 29
Electrical Connections.....	25
Electrical Supply.....	5
Flue Installation.....	5
Fluing.....	12
Gas Safety Regulations.....	4
Gas Supply.....	4
Hydraulic Resistance.....	2
Initial Start Up Lighting.....	29
Introduction.....	3
Installation.....	13
Performance Data.....	2
Positioning of the Turbulators.....	28
Servicing.....	31
Ventilation.....	11
Water Circulation.....	5
Water Connections.....	6
Water System Requirements.....	10 & 11
Water Treatment.....	5
Wiring Diagrams.....	25 & 26

Vanguard 'L'

Gas and Fuel Oil

PI No. 0461BN0658

Destination Countries: GB, IE

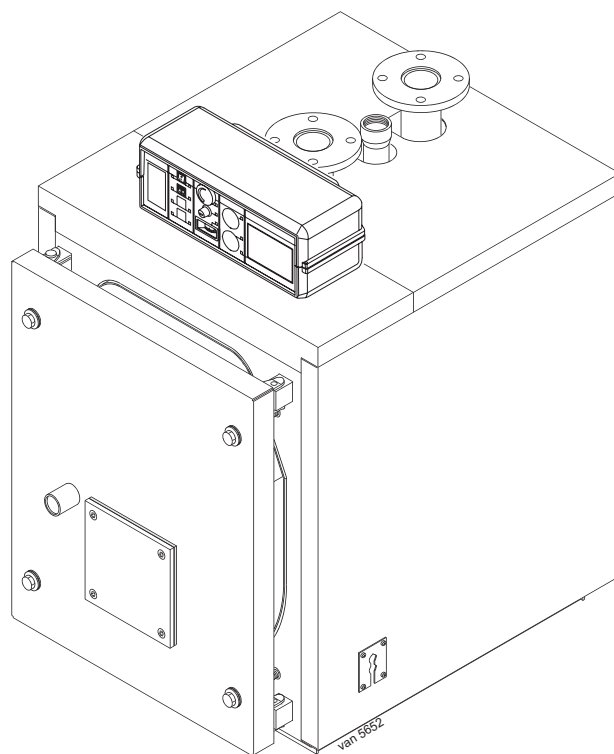

INTRODUCTION

The Vanguard L boilers are a range of steel shell pressure jet boilers offering high efficiency operation, ease of maintenance, fuel flexibility and low emissions.

Suitable for oil or gas operation the Vanguard L range is supplied in a choice of 18 standard models, rated in outputs from 130kW (443,000 Btu/h) to 3500 kW (11,942,000 Btu/h). The range has a maximum operation pressure of 6 bar.

Designed with a large combustion chamber that is positioned in the lower part of the heat exchanger, the Vanguard L range ensures maximum heat transfer efficiency (up to 92.5% net).

Through the use of an increased number of flue ways tubes which are positioned in the hottest area of the heat exchanger and constructed from a thicker steel construction than that of traditional boilers, the Vanguard L range is capable of an impressive output to size ratio.

Duty

The range of boiler is suitable for: combined indirect pumped domestic hot water and central heating systems; independent indirect pumped domestic hot water or central heating systems.

Fully pumped systems may be open vented or sealed.

The range of boilers is NOT suitable for:

1. Gravity DHW systems.
2. Gravity heating systems.
3. Direct domestic hot water supply.

CAUTION. To avoid the possibility of injury during the installation, servicing or cleaning of this appliance, care should be taken when handling edges of sheet steel components.

GENERAL

SAFETY

Current Gas Safety (Installation and Use) Regulations or rules in force.

It is law that all gas appliances are installed and serviced by a Gas Safe Registered Engineer in accordance with the regulations below. Failure to install appliances correctly could lead to prosecution. It is in your own interest, and that of safety, to ensure the law is complied with.

The following must be conformed with:

Current Building Regulations and Clean Air Act

Water Authority Regulations

Local Authority Regulations and Regional Bylaws

Gas Safety Regulations

Any special regional requirements of local Electricity and Gas undertaking.

Fire Service and Insurance Company requirements.

In the interests of safety, a competent installer should be employed to effect the installation of the appliance. Manufacturer's notes must NOT, in any way, be taken as overriding statutory obligations.

The installation of the boiler MUST also be in accordance with the latest I.E.E. (BS7671) Wiring Regulations, local buildings regulations, bye-laws of the local water authority, the building regulations and the Building Standards (Scotland) and any relevant requirements of the local authority.

Detailed recommendations are contained in the following Codes of Practice:

BS 799 Pt4 & 7	Oil burning equipment.
BS 799 Pt5	Oil storage tanks.
BS 5410 Pt2	Installation for space heating, hot water and steam supply.
BS 5854	Flues and flue structures in buildings.
BS 5885 Pt1	Gas burners - with inputs 60kW and above.
BS 6644	Installation of gas fired hot water boilers of rated input between 70kW and 1.8MW net (2nd and 3rd family gases).
BS 6880	Low temperature hot water heating systems of output greater than 45kW.
Part 1	Fundamental and design considerations.
part 2	Selection of equipment.
part 3	Installation, commissioning and maintenance.
BS 6891	Installation of low pressure gas pipework of up to 28mm (R1) in domestic premises (2nd family gas).
EN 303.1	Heating boilers with forced draught burners. General requirements.
EN 303.2	Heating boilers with forced draught burners with atomizing oil burners.

EN 304	Test code for heating boilers for atomizing oil burners.
73/23 EEC	Low voltage directive. (Relevant standard is EN60335.1)
89336 EEC	Electromagnetic Compatibility Directive. (Relevant standards are EN50081.1, EN50082.1 and EN55014.)
90396 EEC	Gas Devices Directive. (Relevant standards are EN303.1, EN303.2 and EN304.)
IGE/UP/1	Soundness testing and purging of industrial and commercial gas installation.
IGE/UP/2	Gas installation pipework, boosters and compressors on industrial and commercial premises.
IGE/UP/10	Installation of gas appliances in industrial and commercial premises.

SAFE HANDLING OF SUBSTANCES

Care should be taken when handling the boiler insulation panels, which can cause irritation to the skin. No asbestos, mercury or CFCs are included in any part of the boiler or its manufacture.

GAS SUPPLY

The local gas supplier should be consulted, at the installation planning stage, in order to establish the availability of an adequate supply of gas. An existing service pipe must NOT be used without prior consultation with the local gas supplier.

A gas meter can only be connected by the local gas supplier or by a Gas Safe Registered Engineer.

An existing meter should be checked, preferably by the gas supplier, to ensure that the meter is adequate to deal with the rate of gas supply required. A minimum working gas pressure of 17.5mbar MUST be available at the boiler inlet for Natural gas and 37mbar for Propane.

Do not use pipes of smaller size than the burner inlet gas connection.

The complete installation MUST be tested for gas soundness and purged in accordance with the appropriate standards listed above.

Gas Boosters

A gas booster is required if the gas pressure available at the burner is lower than that required by the burner manufacturer to attain the flow rate for maximum burner input rating.

Location of the booster requires careful consideration but should preferably be closer to the burner rather than the gas meter. Ventilation should also be considered to ensure ambient temperatures do not exceed designed recommendations. Further guidance is provided in IGE/UP/2 as listed above.

Assembly and Installation Instructions for Ideal Vanguard L heating boilers should be read in conjunction with the general technical data tables enclosed and any other technical publication supplied with the burner.

NOTE TO THE INSTALLER: LEAVE THESE INSTRUCTIONS ADJACENT TO THE BOILER.

FLUE INSTALLATION

IMPORTANT

It is the responsibility of the installer to ensure that products of combustion discharging from the terminal cannot re-enter the building or any other adjacent building.

Fan dilution systems may be incorporated into the flue system. However, ventilation must take into account the additional air requirement of the boiler house and interlocking must be provided to ensure adequate air flow is attained before burner operation proceeds.

The flue must be installed in accordance with the appropriate standards listed on page 4.

WATER CIRCULATION SYSTEM

The system pump **MUST** be connected to the boiler.

The boiler must **NOT** be used for direct hot water supply. The calorifier **MUST** be of the indirect type.

The appliances are **NOT** suitable for gravity central heating nor are they suitable for the provision of gravity domestic hot water.

The calorifier and ancillary pipework, not forming part of the useful heating surface, should be lagged to prevent heat loss and any possible freezing - particularly where pipes run through roof spaces and ventilated underfloor spaces.

The boiler must be vented.

Draining taps **MUST** be located in accessible positions, which permit the draining of the whole system - including the boiler and hot water storage vessel. They should be at least 1/2" BSP nominal size and be in accordance with BS. 2879.

The central heating system should be in accordance with the relevant standards listed on page 4.

Due to the nature of the boiler the heat stored at the point of shutdown of the burner must be dissipated in order to avoid overheating. In order to allow pump operation after burner shutdown the boiler control box incorporates a pump overrun facility. In order to make use of this, the pump must be supplied from the terminals inside the boiler. Note: for pumps requiring greater than 1.0amp current or using 3 phase they must be connected via a relay.

WATER TREATMENT FOR HOT WATER AND HEATING BOILERS

There is a basic need to treat the water contained in all heating and indirect water systems, particularly open vented systems. It is assumed, incorrectly, that because boilers are operating in conjunction with what is apparently a closed circuit an open vented system will not, under normal circumstances, allow damage or loss of efficiency due to hardness salts and corrosion once the initial charge of water has been heated up a few times.

1mm of lime reduces the heat transfer from metal to water by 10%.

In practice the deposition of these salts is liable to cause noises from the boiler body or even premature boiler failure. Corrosion and the formation of black iron oxide sludge will ultimately result in premature radiator failure.

Open vented systems are not completely sealed from the atmosphere if proper venting and expansion of system water is to be achieved. The same tank is used to fill the system with water and it is through the cold feed pipe that system water expands into the tank when the boiler passes heat into the system.

Conversely, when the system cools, water previously expelled is drawn back from the tank into the system together with a quantity of dissolved oxygen.

Even if leakage from the heating and hot water system is eliminated there will be evaporation losses from the surface of the tank which, depending upon ambient temperature, may be high enough to evaporate a large portion of the system water capacity over a full heating season.

There will always be corrosion within a heating or hot water system to a greater or lesser degree, irrespective of water characteristics, unless the initial fill water from the mains is treated. Even the water in closed systems will promote corrosion unless treated. For the reason stated, **Ideal** strongly recommend that when necessary the systems is thoroughly cleaned, prior to the use of stable inhibitor, which does not require continual topping up to combat the effects of hardness salts and corrosion on the heat exchangers of the boiler and associated systems.

Ideal advise contact directly with specialists on water treatment such as:

Betz Dearborn Ltd	or	Fernox Manufacturing Co. Ltd.
Widnes, Cheshire, Tel: 0151 424 5351		Tandem House, Marlowe Way, Croydon, Surrey, CR0 4XS Tel: 0870 601 5000

ELECTRICAL SUPPLY

WARNING This appliance must be earthed.

Control Panel:

A 230V - 50Hz. Fused at 4 amps.

Wiring external to the appliance **MUST** be in accordance with the current I.E.E. (BS7671) Wiring Regulations and any local regulations which apply.

Burner and Pump:

These may be 1ph or 3ph. Refer to manufacturer's instructions.

The point of connection to the mains should be readily accessible and adjacent to the boiler.

LOCATION OF THE BOILER

The boiler must stand on a non-combustible floor (i.e. concrete or brick) which must be flat, level and of a suitable load bearing capacity to support the weight of the boiler (when filled with water) and any ancillary equipment.

If the boiler is mounted on a plinth then the dimensions must exceed the plan area of the boiler by at least 75mm on each side.

The boiler must not be fitted outside.

GENERAL

1 BOILER WATER CONNECTIONS

The Vanguard L boilers are provided with flanged connections for both flow and return.

Dimensions vary depending on the boiler's output and details can be found in the General Data Table on page 4.

The boiler shell is also provided with separate connections for a drain and safety valve.

Dimensional details can also be found in the General Data Table on page 4.

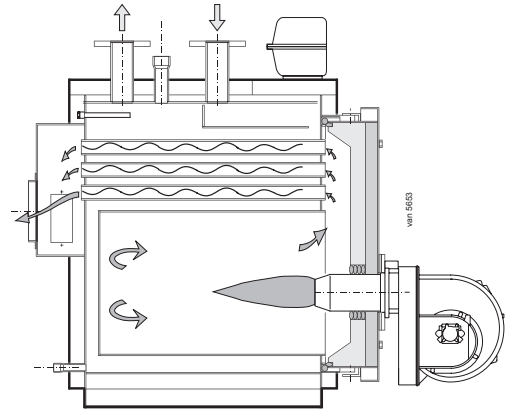

2 BOILER DIMENSIONS

Vanguard L 170 - 630

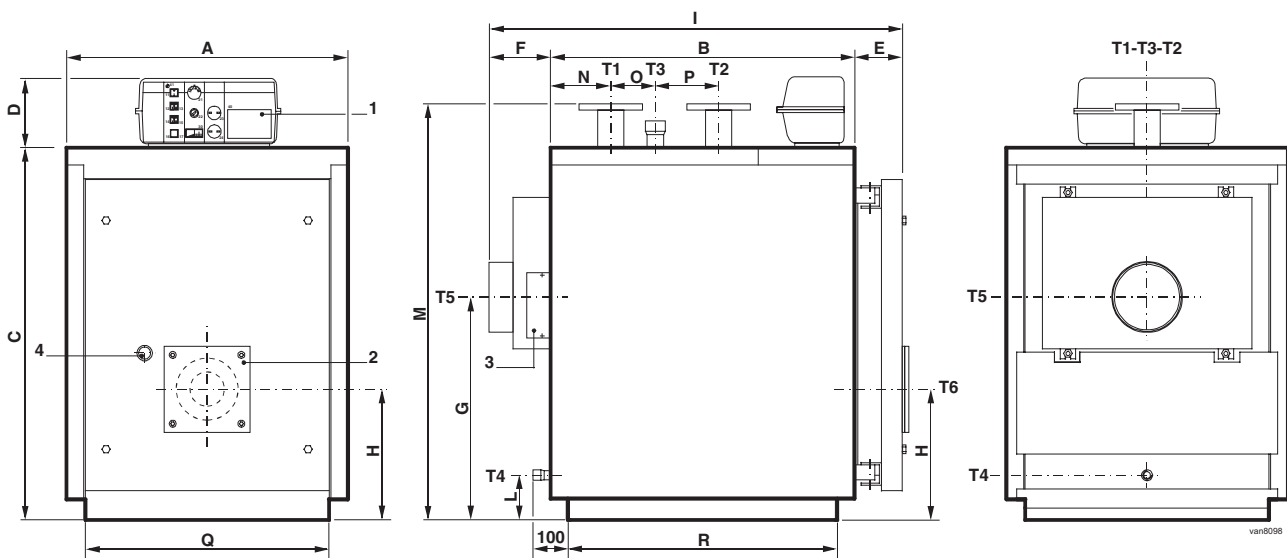

1. Control Panel
2. Burner mating flange with gasket
3. Flue collector hood cleaning door
4. Flame inspection tube with pressure test nipple and cooling line connection

- T1. Flow connection
- T2. Return connection
- T3. Safety valve and expansion connection
- T4. Drain connection
- T5. Flue connection
- T6. Burner connection

Boiler Size		170	240	290	340	420	510	630
Dimension A	mm	820	820	860	860	890	890	890
Dimension B	mm	885	1145	1080	1210	1275	1470	1780
Dimension C	mm	1082	1082	1182	1182	1352	1352	1352
Dimension D	mm	190	190	190	190	190	190	190
Dimension E	mm	139	139	139	139	139	139	139
Dimension F	mm	190	190	190	190	190	190	190
Dimension G	mm	648	648	708	708	748	748	748
Dimension H	mm	380	380	400	400	440	440	440
Dimension I	mm	1214	1474	1411	1541	1606	1801	2113
Dimension L	mm	130	130	130	130	125	125	125
Dimension M*	mm	1210	1210	1310	1310	1485	1485	1485
Dimension N	mm	175	175	215	215	255	255	255
Dimension O	mm	130	390	210	340	285	480	790
Dimension P	mm	185	185	250	250	315	315	315
Dimension Q*	mm	710	710	750	750	780	780	780
Dimension R*	mm	785	1045	982	1112	1177	1372	1682

* Minimum dimensions for boiler room access requirements.

GENERAL

3 BOILER DIMENSIONS CONT'D

Vanguard L 760 - 970

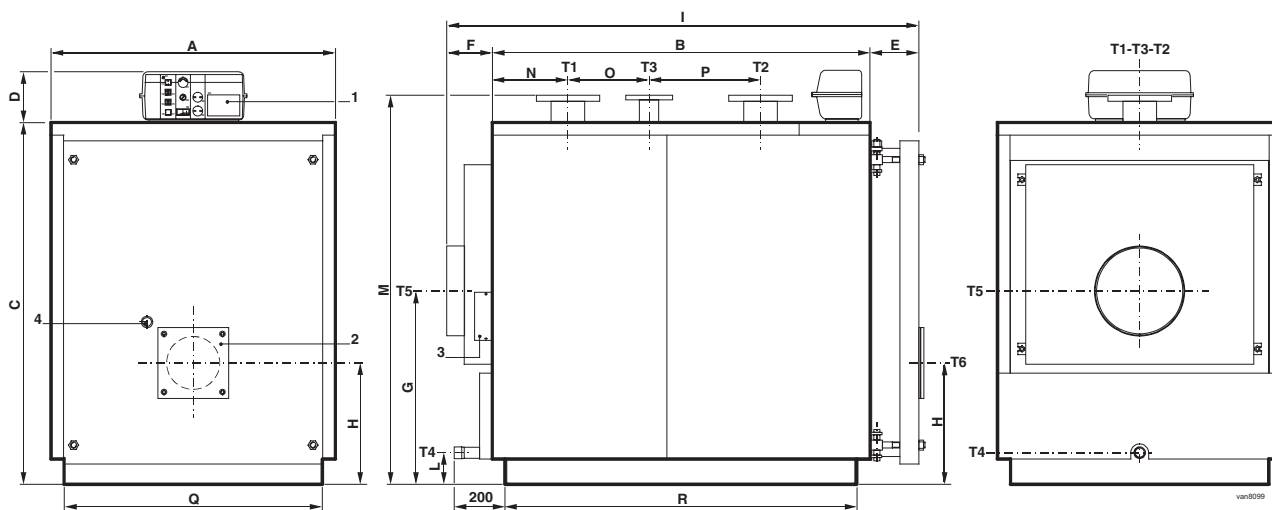

- | | |
|--|---|
| 1. Control Panel | T1. Flow connection |
| 2. Burner mating flange with gasket | T2. Return connection |
| 3. Flue collector hood cleaning door | T3. Safety valve and expansion connection |
| 4. Flame inspection tube with pressure test nipple and cooling line connection | T4. Drain connection |
| | T5. Flue connection |
| | T6. Burner connection |

Boiler Size		760	870	970
Dimension A	mm	1122	1122	1122
Dimension B	mm	1605	1800	1995
Dimension C	mm	1432	1432	1432
Dimension D	mm	190	190	190
Dimension E	mm	195	195	195
Dimension F	mm	190	190	190
Dimension G	mm	765	765	765
Dimension H	mm	480	480	480
Dimension I	mm	1989	2184	2379
Dimension L	mm	125	125	125
Dimension M*	mm	1540	1540	1540
Dimension N	mm	298	298	298
Dimension O	mm	435	630	825
Dimension P	mm	440	440	440
Dimension Q*	mm	1020	1020	1020
Dimension R*	mm	1504	1699	1894

* Minimum dimensions for boiler room access requirements.

GENERAL

4 BOILER DIMENSIONS CONT'D

Vanguard L 1100 - 2650

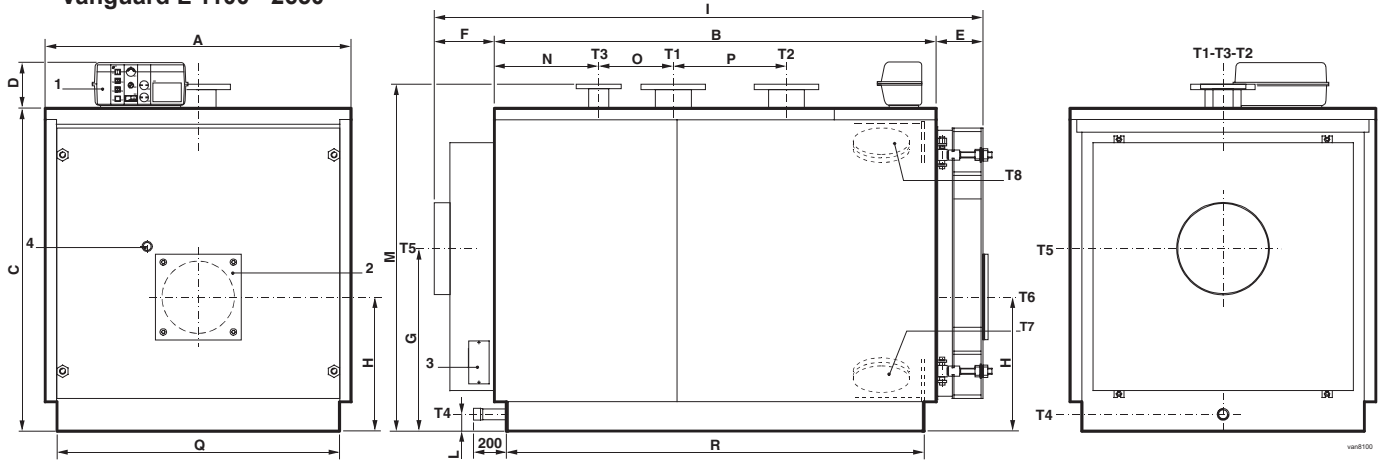

Vanguard L 3000 - 3500

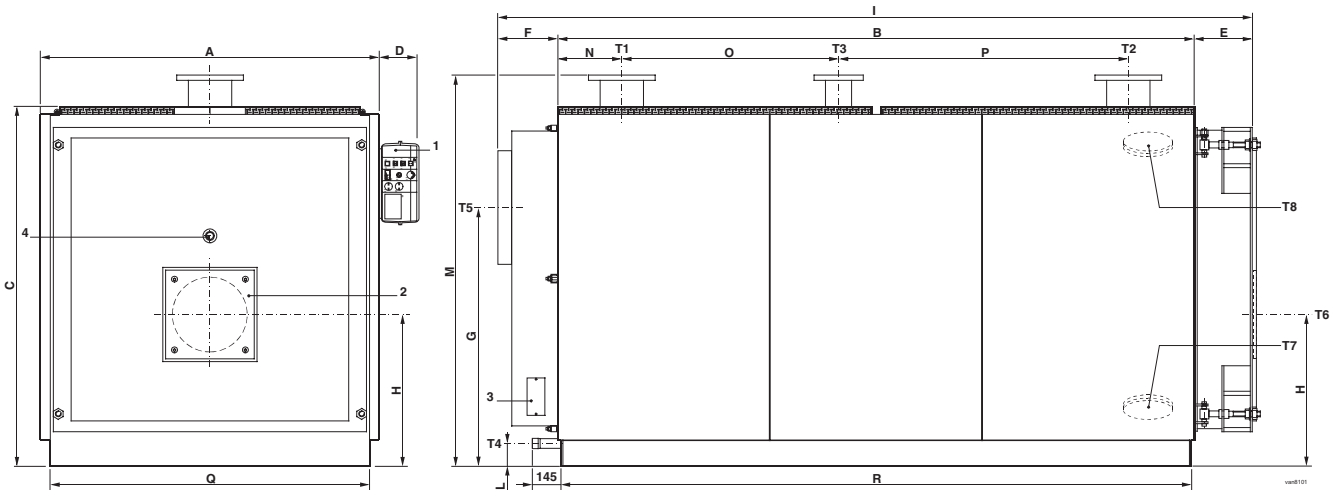

1. Control Panel
2. Burner mating flange with gasket
3. Flue collector hood cleaning door
4. Flame inspection tube with pressure test nipple and cooling line connection

- T1. Flow connection
- T2. Return connection
- T3. Safety valve and expansion connection
- T4. Drain connection

- T5. Flue connection
- T6. Burner connection
- T7. Sludge hole
- T8. Handhole

Boiler Size		1100	1320	1570	1850	2200	2650	3000	3500
Dimension A	mm	1352	1352	1462	1462	1622	1622	1720	1970
Dimension B	mm	1952	2292	2282	2652	2692	3014	3230	3194
Dimension C	mm	1432	1432	1542	1542	1702	1702	1830	2090
Dimension D	mm	190	190	190	190	190	190	190	190
Dimension E	mm	207	207	227	227	259	258	295	325
Dimension F	mm	187	187	272	272	274	273	340	390
Dimension G	mm	810	810	880	880	950	950	1315	1535
Dimension H	mm	595	595	640	640	690	690	772	915
Dimension I	mm	2346	2686	2781	3151	3225	3545	3835	3879
Dimension L	mm	180	180	75	75	75	75	115	144
Dimension M*	mm	1540	1540	1650	1650	1810	1810	1990	2271
Dimension N	mm	461	461	561	561	661	662	325	377
Dimension O	mm	330	670	510	880	670	990	1100	1060
Dimension P	mm	500	500	550	550	700	700	1470	1420
Dimension Q*	mm	1250	1250	1360	1360	1520	1520	1620	1870
Dimension R*	mm	1846	2186	2176	2546	2590	2910	3200	3164

* Minimum dimensions for boiler room access requirements.

5 BOILER LOCATION AND CLEARANCES

Positioning the Boiler

The boiler body should be positioned as near as possible to the installation site. The boiler can be moved into position by the use of rollers under the longitudinal L profiles running the length of the boiler. If it is necessary, due to the dimensions of the boiler, it is possible to remove the front door and the flue collector hood to facilitate moving the boiler into the boiler house.

The boiler must have sufficient space as shown below to maintain minimum clearance. It must also comply to relevant

local by laws and safety regulations. It is advisable to install the boiler as close as possible to the chimney connection on a non combustible floor (i.e. concrete or brick).

The surface must be flat, level, and of a suitable load bearing capacity to support the weight of the boiler (when filled with water - see general data table).

If the boiler is mounted on a plinth then the dimensions (see Frame 2) must exceed the plan area of the boiler by at least 75 mm on each side.

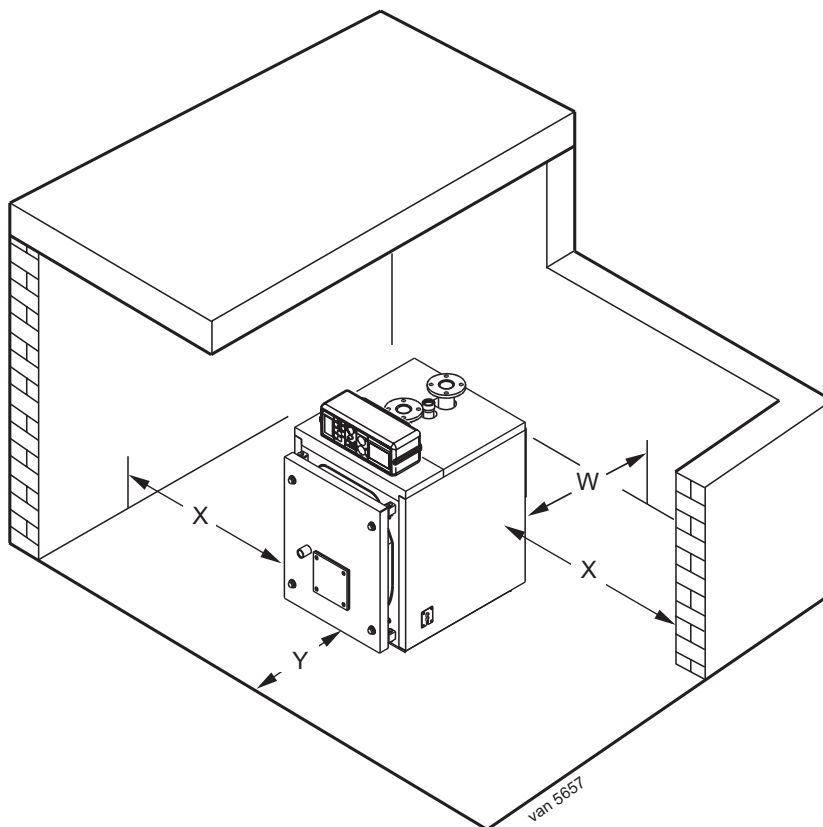

Clearances

The boiler must be positioned so that there is enough space available to allow the following:

- Access around the boiler for servicing.
- Space to open the boiler front door.
- Space to access the burner.

Recommended minimum clearances are as follows:

Rear - All Models

(W) 500mm or adequate space to make the flue connections and access to the flue sample point, drain connection and any safety or control devices.

Sides - Models 170 to 970 and 3000 and 3500

(X) One side may be 100mm (normally the left) to permit access to the burner cable clamp plate, the other side must be 200mm plus the burner projection to allow the burner door to be swung open and maintain access to the rear. In multiple installations consideration must also be given to the burner door hinge position and consequent clearance.

Models 1100 to 2650

One side may be 100mm (normally the left) to permit access to the burner cable clamp plate, the other side must be 200mm plus the burner projection to allow the burner door to be swung open and maintain access to the rear. However, due consideration must be made on the left hand side to provide access to the sludge hole. In multiple installations consideration must also be given to the burner door hinge position and consequent clearance.

Front - All Models

(Y) Not less than the length of the boiler body or 1200mm whichever is the smaller dimension

6 OPEN VENTED SYSTEM - minimum static head requirements

The Vanguard L boiler has a minimum static head requirement of 2.5 metres (8 feet approx.) depending on the particular characteristics of the system design (see diagram).

The information provided is based on the following assumptions:

1. An open vent/safety pipe connection is made from the Safety Valve and Expansion connection point on the boiler body.
2. A cold feed/expansion pipe connection is made to the system return pipe within 0.75m of the boiler return connection.
3. The maximum flow rate through the boiler is based on a temperature difference of 11°C (20°F) at full boiler output with the circulating pump positioned in the flow of the system.

4. The boiler is at the highest point of the system. Systems designed to rise above the flow connections will, of course, automatically require a minimum static head higher than shown.
5. The position of the open vent/safety pipe above the expansion cistern water level is given as a guide only. The final position will depend upon particular characteristics of the system. Pumping over of water into the expansion cistern should be avoided.
6. Both open vent/safety pipe and cold feed/expansion pipes must be of adequate diameter to suit the output of the boiler (see table below).

Boiler Output kW	Open Vent (mm)	Cold Feed (mm)
151 to 300	38	32
301 to 600	50	38
above 600	63	50

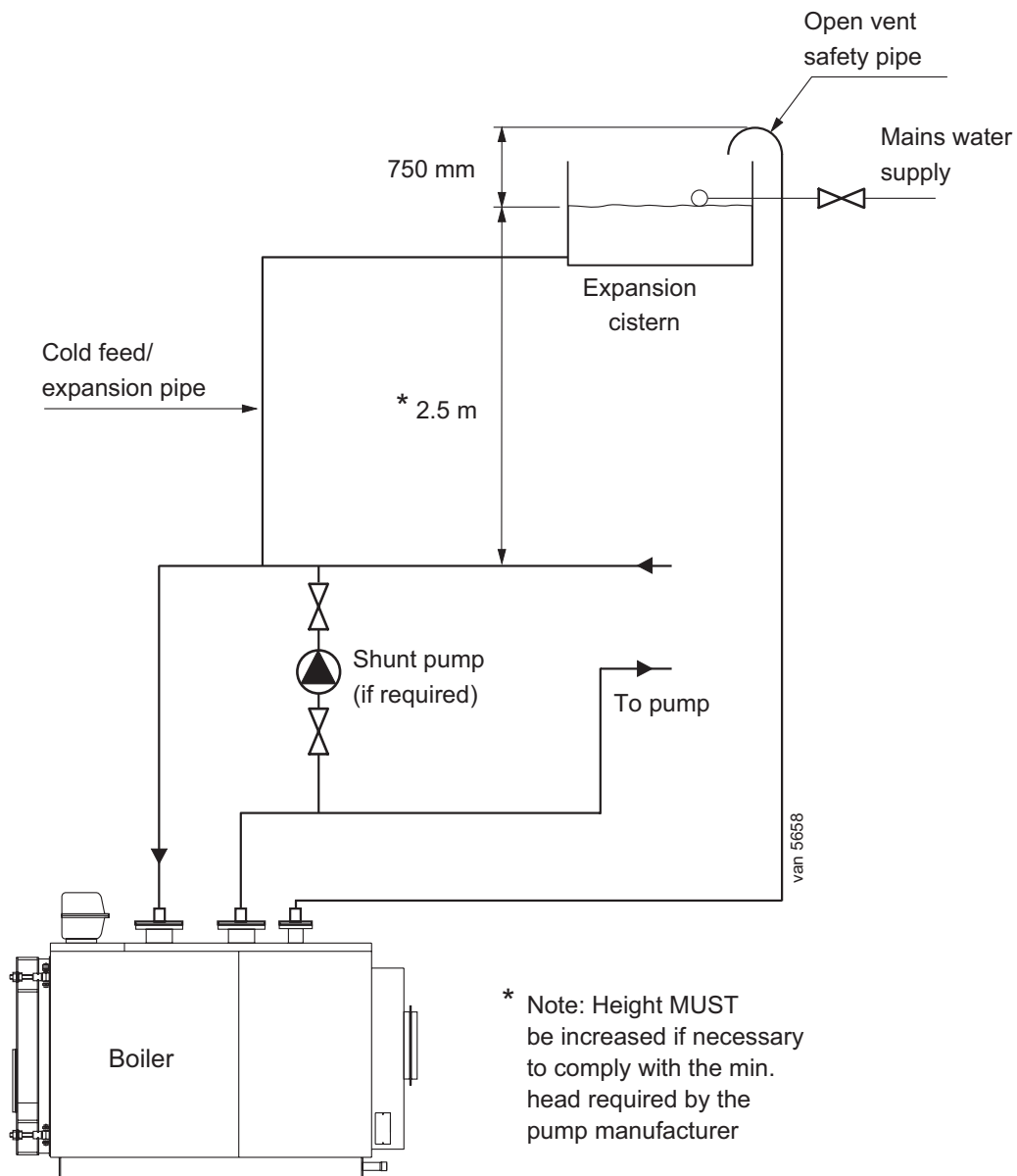

* Note: Height MUST be increased if necessary to comply with the min. head required by the pump manufacturer

7 SEALED (PRESSURISED) SYSTEM

Working pressure 6 bar maximum.

Particular reference should be made to BS 6644: Section 6 and Guidance note PM5 "automatically controlled steam and hot water boilers" published by the Health and Safety Executive.

The information and guidance given below is not intended to override any requirements of either of the above publications or the requirements of the local authority, gas or water undertakings.

In general commercial closed pressurised systems are provided with either manual or automatic water make up.

In both instances it will be necessary to fit automatic controls intended to protect the boiler, circulating system and ancillary equipment by shutting down the boiler plant if a potentially hazardous situation should arise.

Examples of such situations are low water level and operating pressure or excessive pressure within the system.

Depending on circumstances, controls will need to be either manual or automatic reset.

In the event of a shutdown both visual and audible alarms may be necessary.

Expansion vessels used must comply with BS. 4814 and must be sized on the basis of the total system volume and initial

charge pressure.

Initial minimum charge pressure should not be less than 0.5 bar (7.2 psi) and must take account of the static head and specification of the pressurising equipment. The maximum water temperatures permissible at the point of minimum pressure in the system are specified in Guidance Note PM5.

When make up water is not provided automatically it will be necessary to fit controls which shut down the plant in the event of the maximum system pressure approaching to within 0.5 bar (5 psi) of the safety valve setting.

Other British Standards applicable to commercial sealed systems are:

BS6880: Part 2

BS 1212

BS 6281: Part 1

BS 6282: Part 1

BS 6283: Part 4

8 VENTILATION

Safe, efficient and trouble-free operation of conventionally flued gas boilers is vitally dependent on the provision of an adequate supply of fresh air to the room in which the appliance is installed.

Ventilation by grilles communicating directly with the outside air is required at both high and low levels. The minimum free areas of these grilles must be according to the following scale in Table 4.

Table 4 - Ventilation Requirements

Required area (cm²) per kW of total rated input (net)

	Boiler Room	Enclosure
Low level (inlet)	4	10
High level (outlet)	2	5

Note.

Where a boiler installation is to operate in summer months (e.g. DHW) additional ventilation requirements are stated, if operating for more than 50% of time. (Refer to BS 6644)

Position ventilation grilles to avoid the risk of accidental obstruction by blockage or flooding. If further guidance on ventilation is required then consult BS 6644.

The supply of air by mechanical means to a space housing the boiler should be by mechanical inlet with natural or mechanical extraction. Mechanical extract ventilation with natural inlet must not be used.

Where a mechanical inlet and a mechanical extract system is applied, the design ventilation flow rates should be as in BS 6644.

Note.

For mechanical ventilation systems an automatic control should be provided to cause safety shutdown or lockout of the boiler(s) in the event of failure of air flow in either inlet or extract fans.

IMPORTANT. The use of an extractor fan in the same room as the boiler (or in an adjacent communicating room) can, in certain conditions, adversely affect the safe operation of the boiler.

Where such a fan is already fitted (or if it is intended to fit an extractor fan after installation of the appliance) the advice of the gas supplier should be obtained.

9 FLUING

General

Flues shall be constructed of suitable materials. The installer must respect the usual precautions (dilution, piping, 'T' for removal of condensation) in order to prevent deterioration of the chimney.

Routing

The route of any flue shall be as direct as practicable avoiding horizontal runs and 90° bends.

Entry into a masonry chimney shall be inclined upwards at 45°.

Flue Size

Refer to applicable regulations while determining the size and height of the flue. Please note that Vanguard L boilers have pressurised and sealed combination chambers and that the pressure at the outlet must not exceed 0 mbar.

Detailed recommendations relating to the design of flues for GAS fired appliances are quoted in BS. 6644 and IGE/UP/10, whilst BS. 5410 Pt. 2 similarly applies to OIL fired boilers.

Flues should not be less in diameter than the boiler outlet connection size. Refer to Table 1.

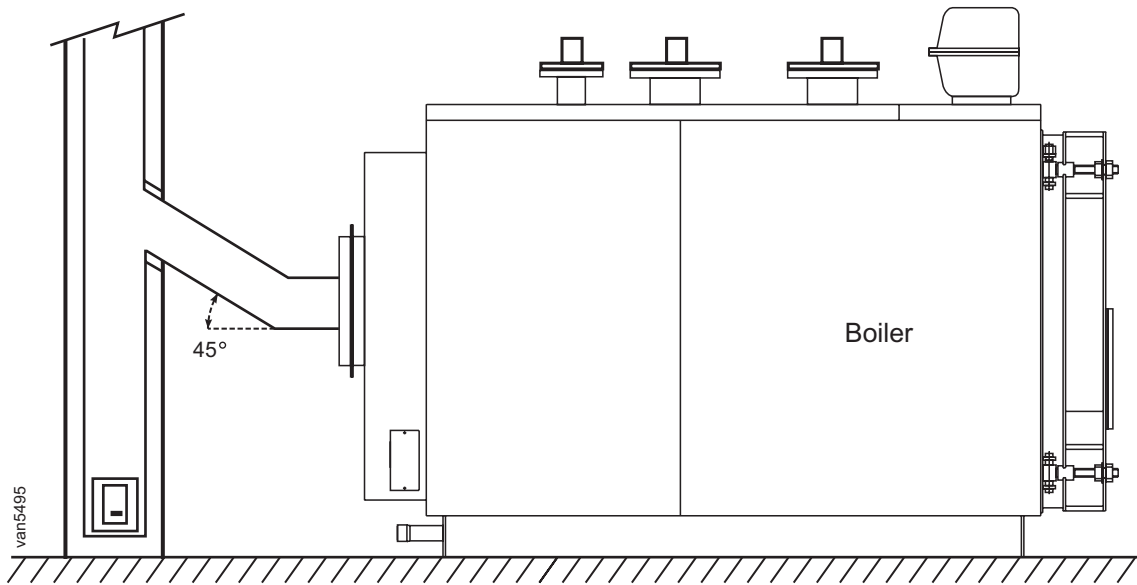

INSTALLATION

10 PACKAGING

The boiler is supplied in the following packages:

- Boiler body assembly
- Separate jacket parts
- The control pack, accessory pack, literature pack and hardware items are stored inside the combustion chamber.

Check that all these packages are complete and have been correctly received on site.

Refer to Frames 11 and 12.

INSTALLATION

11 JACKET COMPONENTS

LIST OF JACKET'S COMPONENTS

BOILER MODEL No.	170	240	290	340	420	510	630	760	870	970	1100	1320	1570	1850	2200	2650	3000	3500
Box Code VAL	01	02	03	04	05	06	09	12	14	16	19	21	24	26	29	31	35	38
Right Side Jacket	1	1	1	1	1	1	-	-	-	-	-	-	-	-	-	-	-	-
Left Side Jacket	1	1	1	1	1	1	-	-	-	-	-	-	-	-	-	-	-	-
Upper Rear Jacket	1	1	1	1	1	1	1	1	1	1	1	1	1	1	1	1	-	-
Lower Rear Jacket	1	1	1	1	1	1	1	1	1	1	-	-	-	-	-	-	-	-
Upper Front Jacket	1	1	1	1	1	1	1	1	1	1	1	1	1	1	1	1	-	-
Upper Rear Right Jacket	1	1	1	1	1	1	1	1	1	1	1	1	1	1	1	1	-	-
Upper Rear Left Jacket	1	1	1	1	1	1	1	1	1	1	1	1	1	1	1	1	-	-
Upper Rear Central Right Jacket	-	-	-	-	-	-	-	-	-	-	-	-	-	-	-	1	-	-
Upper Rear Central Left Jacket	-	-	-	-	-	-	-	-	-	-	-	-	-	-	-	1	-	-
Support for the Upper Jacket	-	-	-	-	-	-	-	-	-	-	-	-	-	-	-	1	-	-
Body Insulation	1	1	1	1	1	1	-	-	-	-	-	-	-	-	-	-	-	-
Front Insulation	1	1	1	1	1	1	-	-	-	-	-	-	-	-	-	-	-	-
Rear Insulation	1	1	1	1	1	1	-	-	-	-	-	-	-	-	-	-	-	-
Central Body Insulation	-	-	-	-	-	-	-	-	-	-	-	-	-	-	-	-	1	1
Rear Side Jacket	-	-	-	-	-	-	-	-	-	-	-	-	-	-	-	-	2	2
Spare Parts Plastic Bag	1	1	1	1	1	1	-	-	-	-	-	-	-	-	-	-	-	-
Box Code VAL							07	10	10	10	17	17	22	22	27	27	33	36
Front Right Side Jacket	-	-	-	-	-	-	1	1	1	1	1	1	1	1	1	1	1	1
Front Left Side Jacket	-	-	-	-	-	-	1	1	1	1	1	1	1	1	1	1	1	1
Front/Rear Jacket	-	-	-	-	-	-	-	-	-	-	-	-	-	-	-	-	-	-
Upper Front Jacket	-	-	-	-	-	-	-	-	-	-	-	-	-	-	-	-	-	-
Supp. for the Right Side Jacket	-	-	-	-	-	-	-	-	-	-	-	-	-	-	-	-	-	-
Supp. for the Left Side Jacket	-	-	-	-	-	-	-	-	-	-	-	-	-	-	-	-	-	-
Front Insulation	-	-	-	-	-	-	1	1	1	1	-	-	-	-	-	-	-	-
Front Body Insulation	-	-	-	-	-	-	1	1	1	1	1	1	1	1	1	1	1	1
Upper Front Insulation	-	-	-	-	-	-	-	-	-	-	1	1	1	1	1	1	-	-
Lower Front Insulation	-	-	-	-	-	-	-	-	-	-	1	1	1	1	1	1	-	-
Spare Parts Plastic Bag	-	-	-	-	-	-	1	1	1	1	1	1	1	1	1	1	-	-
Box Code VAL							08	11	13	15	18	20	23	25	28	30	-	-
Rear Right Side Jacket	-	-	-	-	-	-	1	1	1	1	1	1	1	1	1	1	-	-
Rear Left Side Jacket	-	-	-	-	-	-	1	1	1	1	1	1	1	1	1	1	-	-
Rear Insulation	-	-	-	-	-	-	1	1	1	1	-	-	-	-	-	-	-	-
Rear Body Insulation	-	-	-	-	-	-	1	1	1	1	1	1	1	1	1	1	-	-
Central Body Insulation	-	-	-	-	-	-	-	-	-	-	-	-	-	1	1	-	-	-
Box Code VAL																32	34	37
Central Side Jacket	-	-	-	-	-	-	-	-	-	-	-	-	-	-	-	-	2	2
Central Right Side Jacket	-	-	-	-	-	-	-	-	-	-	-	-	-	-	-	1	-	-
Central Left Side Jacket	-	-	-	-	-	-	-	-	-	-	-	-	-	-	-	1	-	-
Central Body Insulation	-	-	-	-	-	-	-	-	-	-	-	-	-	-	-	1	-	-
Rear Body Insulation	-	-	-	-	-	-	-	-	-	-	-	-	-	-	-	-	1	1

INSTALLATION

12 ACCESSORIES BOX COMPONENTS

in Combustion Chamber

BOILER MODEL No.		170	240	290	340	420	510	630	760	870	970	1100	1320	1570	1850	2200	2650	3000	3500		
Box Code	VAL	41	41	42	42	43	43	44	44	44	44	45	45	46	46	47	47	48	49		
PLASTIC BAG	Arcuated Spring	2	2	2	2	2	2	2	2	2	2	2	2	2	2	2	2	1	1		
	Elastic Claw for Ins. Fastening	9	10	10	16	16	16	18	18	18	20	20	22	22	26	26	29	29			
	Round Brush \varnothing 41 mm	1	1	1	1	1	1	1	1	1	1	1	1	1	1	1	1	1	1	-	
	Round Brush \varnothing 56 mm	-	-	-	-	-	-	-	-	-	-	-	-	-	-	-	-	-	-	1	
	Nut	-	-	-	-	-	-	-	-	-	-	-	16 M20	16 M20	16 M20	16 M20	24 M20	24 M20	24 M20	24 M20	
	Nut	8 M16	8 M16	16 M16	16 M16	16 M16	16 M16	16 M16	20 M16	20 M16	20 M16	20 M16	16 M16	16 M16	16 M16	16 M16	16 M16	16 M16	16 M16	16 M16	16 M16
	Screw	8 M12x60	8 M12x60	8 M16x70	8 M16x70	8 M16x70	8 M16x70	8 M16x70	16 M16x70	16 M16x70	16 M16x70	16 M16x70	16 M20x80	16 M20x80	16 M20x80	16 M20x80	16 M20x80	16 M20x80	16 M20x80	16 M20x80	
	Screw	-	-	-	-	-	-	-	4 M16x60	4 M16x60	4 M16x60	4 M16x60	4 M16x70	4 M16x70	4 M16x70	4 M16x70	4 M16x70	4 M16x70	4 M16x70	4 M16x70	
	Plastic Strap 160x3	6	6	6	6	6	6	6	6	6	6	6	6	6	6	6	6	6	6	-	
	Flange Gasket	-	-	-	-	-	-	-	1 DN65	1 DN65	1 DN65	1 DN80	1 DN80	1 DN100	1 DN100	1 DN125	1 DN125	1 DN125	1 DN125	1 DN125	
Flange Gasket	2 DN65	2 DN65	2 DN80	2 DN80	2 DN100	2 DN100	2 DN100	2 DN125	2 DN125	2 DN125	2 DN150	2 DN150	2 DN175	2 DN175	2 DN175	2 DN200	2 DN200	2 DN200	2 DN200		
Multiple Cable Clamp	4	4	4	4	4	4	4	4	4	4	4	4	4	4	4	4	4	4	-		
Flange	-	-	-	-	-	-	-	1 DN65	1 DN65	1 DN65	1 DN80	1 DN80	1 DN100	1 DN100	-	-	-	-	-		
Flange	2 DN65	2 DN65	2 DN80	2 DN80	2 DN100	2 DN100	2 DN100	-	-	-	-	-	-	-	-	-	-	-	-		
Ceramic Fiber 25x25	-	-	-	-	-	-	-	-	-	-	-	-	-	-	-	-	-	-	1 lg.3660		
Ceramic Fiber 25x25	1 lg.3660	1 lg.3660	1 lg.3660	1 lg.3660	1 lg.3660	1 lg.3660	1 lg.3660	1 lg.3660	1 lg.3660	1 lg.3660	1 lg.3660	1 lg.7320	1 lg.7320	1 lg.7320	1 lg.7320	1 lg.7320	1 lg.7320	1 lg.7320	1 lg.7320		

13 HARDWARE ITEMS

in Combustion Chamber

BOILER MODEL No.	170	240	290	340	420	510	630	760	870	970	1100	1320	1570	1850	2200	2650	3000	3500
Brush Handle	1 lg.700	1 lg.700	1 lg.600	1 lg.700	1 lg.800	1 lg.500	1 lg.700	1 lg.600	1 lg.700	1 lg.900	1 lg.900	1 lg.700	1 lg.700	1 lg.500	1 lg.600	1 lg.900	1 lg.600	1 lg.600
Brush Handle Extension	1 lg.275	1 lg.550	1 lg.550	1 lg.550	1 lg.550	1 lg.1100	1 lg.1100	1 lg.1100	1 lg.1100	1 lg.1100	1 lg.1100	1 lg.550	1 lg.550	1 lg.1100	1 lg.1100	1 lg.1100	1 lg.550	1 lg.550
Brush Handle Extension	-	-	-	-	-	-	-	-	-	-	-	1 lg.1100	1 lg.1100	-	-	-	2 lg.1100	2 lg.1100
Flange	-	-	-	-	-	-	-	-	-	-	-	-	-	-	1 DN125	1 DN125	1 DN125	1 DN125
Flange	-	-	-	-	-	-	2 DN125	2 DN125	2 DN125	2 DN150	2 DN150	2 DN150	2 DN175	2 DN175	2 DN200	2 DN200	2 DN200	2 DN200
Turbulator Extractor	-	-	-	-	-	-	-	-	-	-	-	-	1 lg.1000	1 lg.1000	1 lg.1000	1 lg.1000	1 lg.980	1 lg.1000
Turbulator Extractor	1 lg.390	1 lg.570	1 lg.570	1 lg.570	1 lg.570	1 lg.570	1 lg.570	1 lg.570	1 lg.570	1 lg.570	1 lg.570	1 lg.570	1 lg.570	-	-	-	-	-
Turbulator Core	26 lg.700	26 lg.700	33 lg.700	33 lg.700	44 lg.700	44 lg.700	46 lg.700	58 lg.700	58 lg.700	-	-	-	-	-	-	-	-	-
Tubulator	26	26	33	33	44	44	46	58	58	58	69	69	84	84	109	109	123	99

Control Pack (all models)

- Control Panel
- 7 Way Burner Cable
- Instruction Sheet

Literature Pack (all models)

- Ideal Installation and Servicing Instructions
- Ideal User's Instructions
- Ideal Data Plate
- Ideal Log Book - Pressure Jet
- Ideal Warranty Literature
- Ideal Casing Badge
- 7 Pole Burner Plug
- 4 Pole Burner Plug
- 4 Way Burner Cable

INSTALLATION

14 FLUE CONNECTION

1. Complete the secondary flue connection.
2. Seal with an approved boiler putty.
3. A split socket should be fitted immediately above the boiler to facilitate disconnection of the flue.

15 CASING ASSEMBLY

Vanguard L 170 to 630

For boiler models 170 to 510 the casing and insulation are contained in one carton and for model 630 in 3 cartons.

Assembly of the casing should be carried out in the following steps:

Refer to diagram below for details

- A.** Fit the insulation blanket (1) onto the boiler shell and secure in to place using the elasticated straps (2) provided, ensuring that the metal clips grip in to the external surface of the insulation.
- B.** Locate the side panels (3) and (4) with the lower bend inside the bottom L profiles and the upper bend in the seats of front and rear tube plates.
To determine which is the left and right panel ensure that the cable clamp plates are positioned toward the front edge.
- C.** Open the combustion chamber door and fit the front insulation (5), inserting the hinges in the pre-cuts. Insert the side end of the insulation under the bend of the two side panels (3 and 4).
- D.** Fit the rear insulation (6), fix the rear lower and upper retaining strips (7 and 8), with the self tapping screws. Fit the plastic cable clamps (9) to the upper rear panel (8).
- E.** Fit the 'Ideal' badge to the front edge of the front top panel (10) and secure with the rubber fixings.
- F.** Fit the control panel to front top panel. Refer to Frame 16. Remove the upper shell of the control panel and insert the capillaries of thermometer and thermostats through the slots. Position the front top panel and press on to the side panels.
- G.** Insert the thermometer and thermostat bulbs in the sensor pockets as shown in Frame 16 and connect the mains, the burner, the pump(s) and any equipment to the control panel. Refit the upper shell of the control panel.
Guide the burner plug through the side cable clamp plate (11) and clamp the cable using the cable clamp supplied. Fix the side cable clamp plates to the casing side panels. Fit the cables leaving the boiler from rear panel, with the plastic screws of the cable clamps (9).
- H.** Position the top panels (12 and 13) and press them against the side panels.
- I.** Remove the protective paper film from data plate and ventilation requirement label (14 and 15) and fit them at the top front corner of the most accessible side panel after removal of dust from the surface.
Data plate and ventilation requirements labels are in the plastic bag containing the documents.

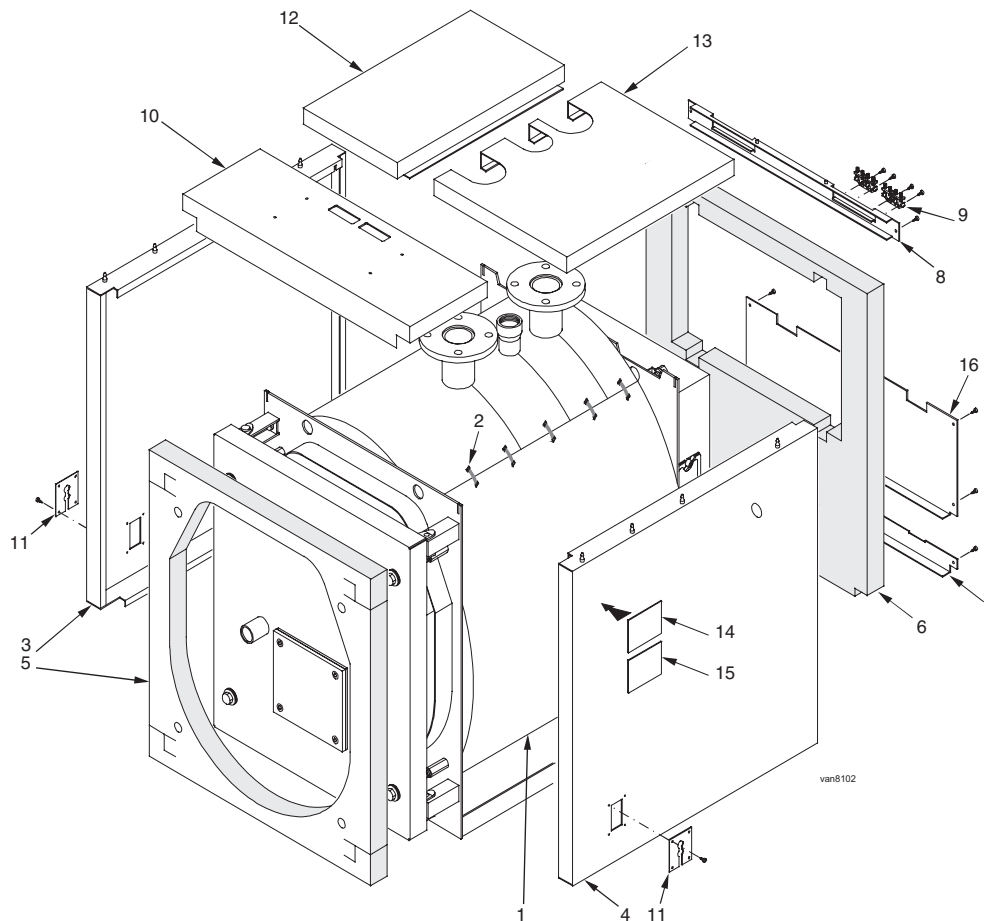

INSTALLATION

16 POSITION OF THERMOMETER/THERMOSTAT SENSOR IN THE BULB HOLDER

Vanguard L 170 to 970

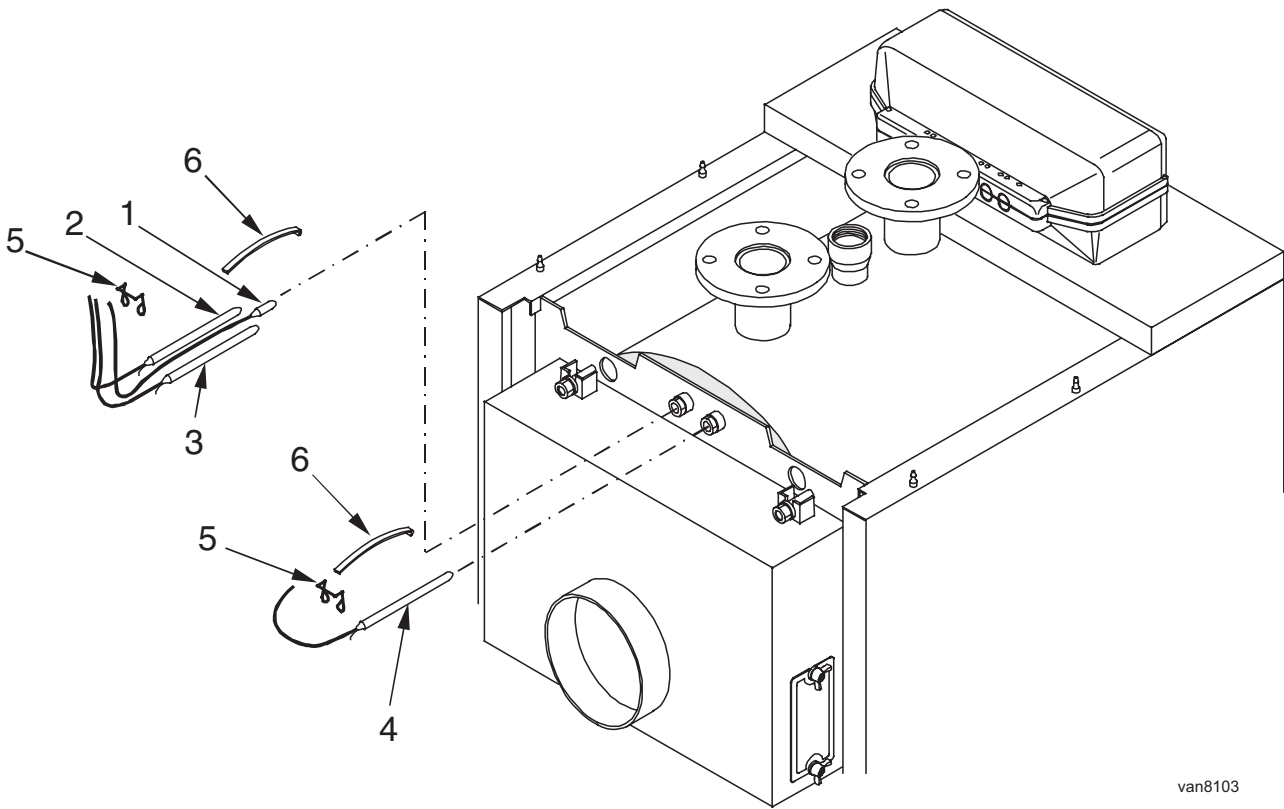

van8103

LEGEND

1. Thermometer bulb
2. Operation thermostat bulb
3. Safety thermostat bulb
4. Minimum temp. thermostat bulb
5. Sensor retaining clip
6. Contact spring

17 CASING ASSEMBLY

Vanguard L 760 to 970

For these boiler models the casing and insulation are contained in 3 cartons.

Assembly of the casing should be carried out in the following steps:

Refer to diagram below for details.

A. Fit the insulation blanket (1) onto the boiler shell and secure into place using the elasticated straps (2) provided, ensuring that the metal clips grip into the external surface of the insulation.

B. Locate the side panels (3) and (4) with the lower bend inside the bottom L profiles and the upper bend inside the upper L profile. The head of the self tapping screw fixed to the L profile has to coincide with the slot on the bend of the side panel.

To determine which is the left and right panel ensure that the cable clamp plate (5) is positioned toward the front edge.

Fix the countersink screws (8) to the side panels pos. 3b and 4b, inner rear side.

C. Open the combustion chamber door and fit the front insulation (6), inserting the hinges in the precuts.

Insert the side end of the insulation under the bend of the two side panels (3 and 4).

D. Fit the rear insulation (7), fix the rear lower panels (9) with pins and springs and the upper panel (10) with the self tapping screws (8). Fit the plastic cable clamps (11) to the upper rear panel (10).

E. Fit the 'Ideal' badge to the front edge of the front top panel (12) and secure with the rubber fixings.

F. Fit the control panel to front top panel (12). Remove the upper shell of the control panel and insert the capillaries of thermometer and thermostats through the slots.

G. Insert the thermometer and thermostat bulbs in the bulb holders as shown in Frame 16 and connect the mains, the burner, the pump(s) and any equipment to the control panel. Refit the upper shell of the control panel.

Guide the burner plug through the side cable clamp plate (5) on the left or right side opposite the burner door hinge and clamp the cable using the cable clamp supplied.

Fix the side cable clamp plates to the casing side panels.

Fit the cables leaving the boiler from the rear panel, with the plastic screws of the cable clamps (11).

H. Position the top panels (13 and 14) and press them against the side panels.

I. Remove the protective paper film from data plate and ventilation requirement label (15 and 16) and fit them at the top front corner of the most accessible side panel after removal of dust from the surface.

Data plate and ventilation requirements labels are in the plastic bag containing the documents.

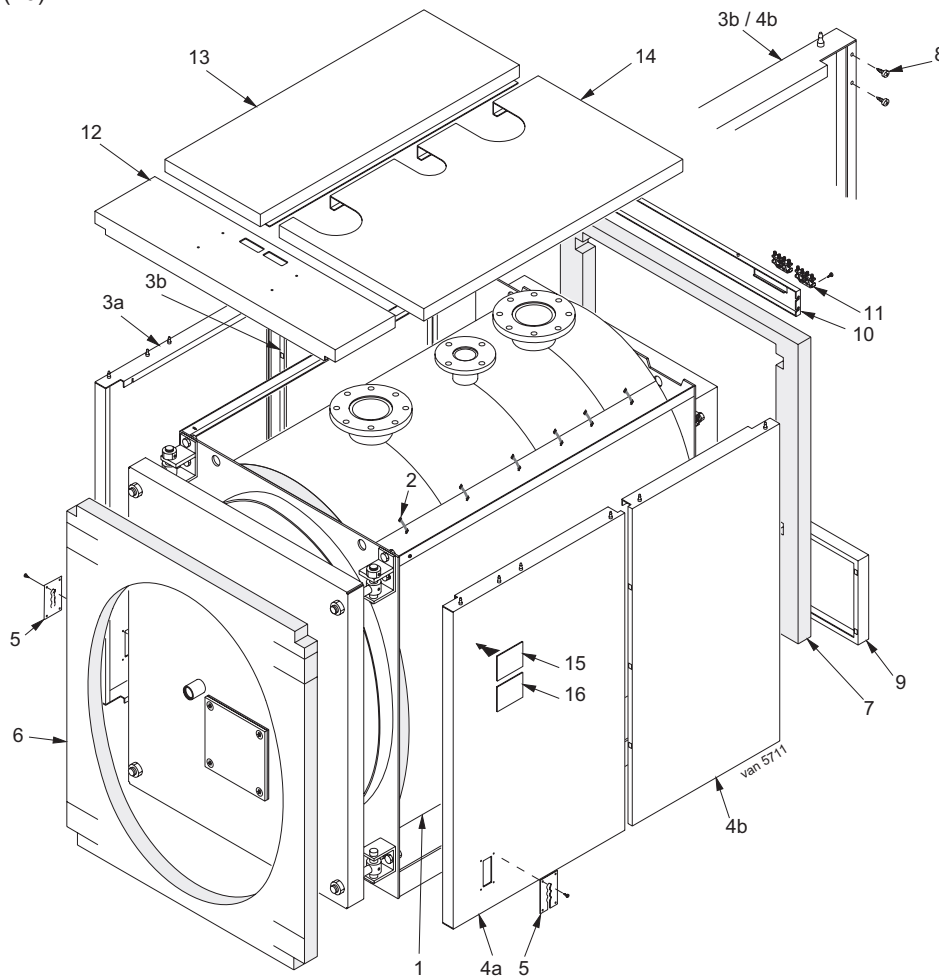

INSTALLATION

18 CASING ASSEMBLY

Vanguard L 1100 to 2200

For these boiler models the casing and insulation are contained in 3 cartons.

Assembly of the casing should be carried out in the following steps:

Refer to diagram below for details

A. Fit the insulation blanket (1) onto the boiler shell and secure into place using the elasticated straps (2) provided, ensuring that the metal clips grip into the external surface of the insulation.

B. Locate the side panels (3) and (4) with the lower bend inside the bottom L profiles and the upper bend inside the upper L profile. The head of the self tapping screw fixed to the L profile has to coincide with the slot on the bend of the side panel.

To determine which is the left and right panel ensure that the cable clamp plate (5) is positioned toward the front edge.

C. Open the combustion chamber door and fit the front insulation (6), inserting the hinges in the precuts.

D. Fit the rear upper panel (7), and fit the plastic cable clamps (8) to it.

E. Fit the 'Ideal' badge to the front edge of the front top panel (9) and secure with the rubber fixings (10) and secure with the rubber fixings.

F. Fit the control panel to front top panel (9). Remove the upper shell of the control panel and insert the capillaries of thermometer and thermostats through the slots.

G. Insert the thermometer and thermostat bulbs in the bulb holders as shown in Frame 21 and connect the mains, the burner, the pump(s) and any equipment to the control panel.

Refit the upper shell of the control panel.

Guide the burner plug through the side cable clamp plate (5) on the left or right side opposite the burner door hinge and clamp the cable using the cable clamp supplied.

Fix the side cable clamp plates to the casing side panels.

Fit the cables leaving the boiler from rear panel, with the plastic screws of the cable clamps (8).

H. Position the top panels (10 and 11) and press them against the side panels.

I. Remove the protective paper film from data plate and ventilation requirement label (12 and 13) and fit them at the top front corner of the most accessible side panel after removal of dust from the surface.

Data plate and ventilation requirements labels are in the plastic bag containing the documents.

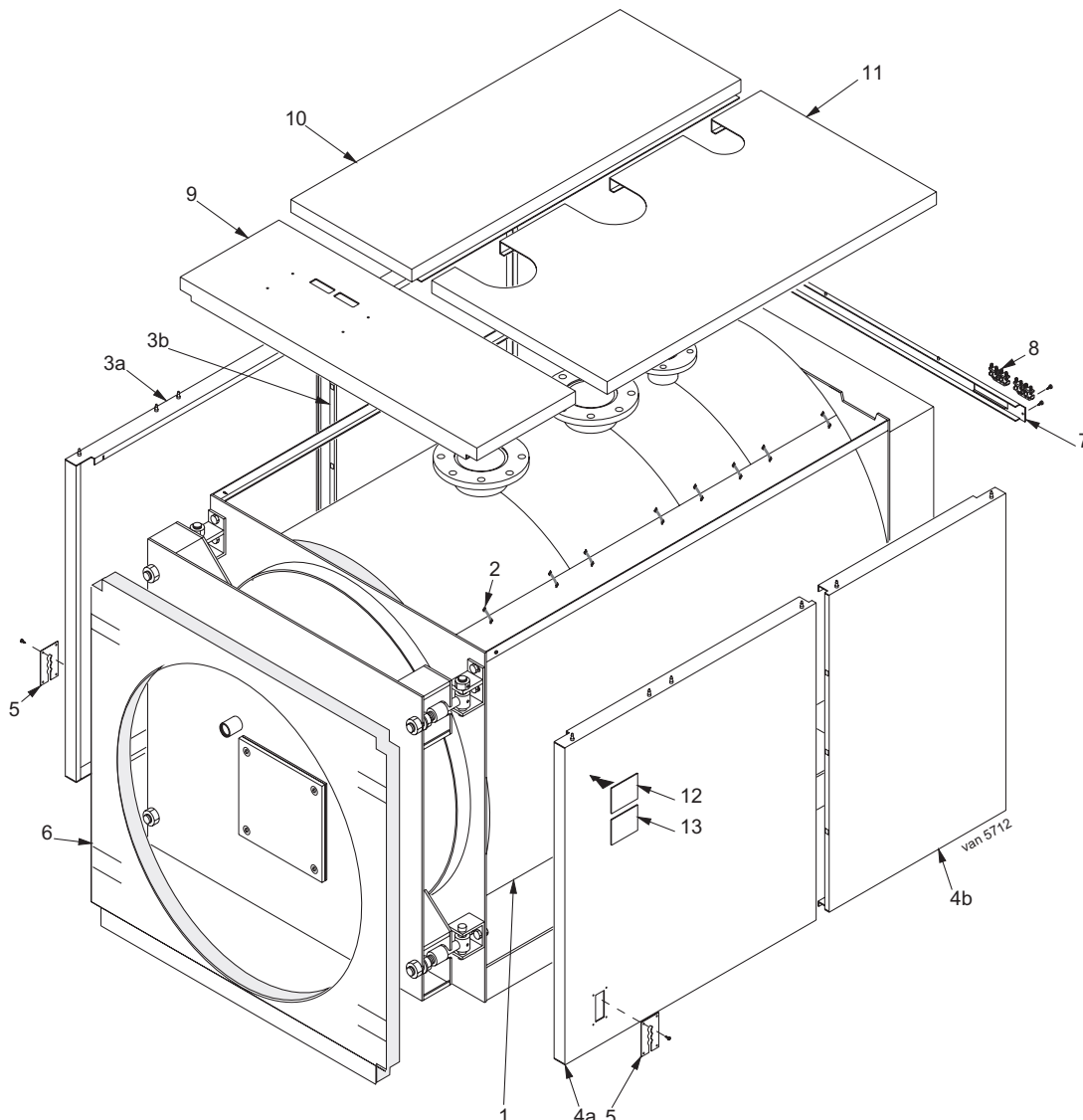

19 CASING ASSEMBLY

Vanguard L 2650

For this boiler model the casing and insulation are contained in 4 cartons.

Assembly of the casing should be carried out in the following steps:

Refer to diagram below for details.

- A.** Fit the insulation blanket (1) onto the boiler shell and secure into place using the elasticated straps (2) provided, ensuring that the metal clips grip into the external surface of the insulation.

In order to fit the bulb holders in the upper part of the shell a cut has to be made.

- B.** Locate the side panels (3) and (4) with the lower bend inside the bottom L profiles and the upper bend inside the upper L profile. The head of the self tapping screw fixed to the L profile has to coincide with the slot on the bend of the side panel.

To determine which is the left and right panel ensure that the cable clamp plate (5) is positioned toward the front edge.

- C.** Fit the rear upper panel (6), and fit the plastic cable clamps (7) to it.
- D.** Open the combustion chamber door and fit the front insulation (15), inserting the hinges in the pre-cuts.
- E.** Fit the 'Ideal' badge to the front edge of the front top panel (8) and secure with the rubber fixings.

- F.** Fit the control panel to front top panel (8). Remove the upper shell of the control panel and insert the capillaries of thermometer and thermostats through the slots.

- G.** Insert the thermometer and thermostat bulbs in the bulb holders as shown in Frame 21 and connect the mains, the burner, the pump(s) and any equipment to the control panel.

Refit the upper shell of the control panel.

Guide the burner plug through the side cable clamp plate (5) on the left or right side opposite the burner door hinge and clamp the cable using the cable clamp supplied.

Fix the side cable clamp plates to the casing side panels.

Fit the cables leaving the boiler from the rear panel with the plastic screws of the cable clamps (7).

- H.** Position the top panels (9 and 10) and press them against the side panels.

- I.** Fit the support (11) positioning it under the rear side of the top panels (9 and 10).

- J.** Fit the rear top panels (12 and 13) and press them against the side panels.

- K.** Remove the protective paper film from data plate and ventilation requirement label (14 and 15) and fit them at the top front corner of the most accessible side panel after removal of dust from the surface.

Data plate and ventilation requirements labels are in the plastic bag containing the documents.

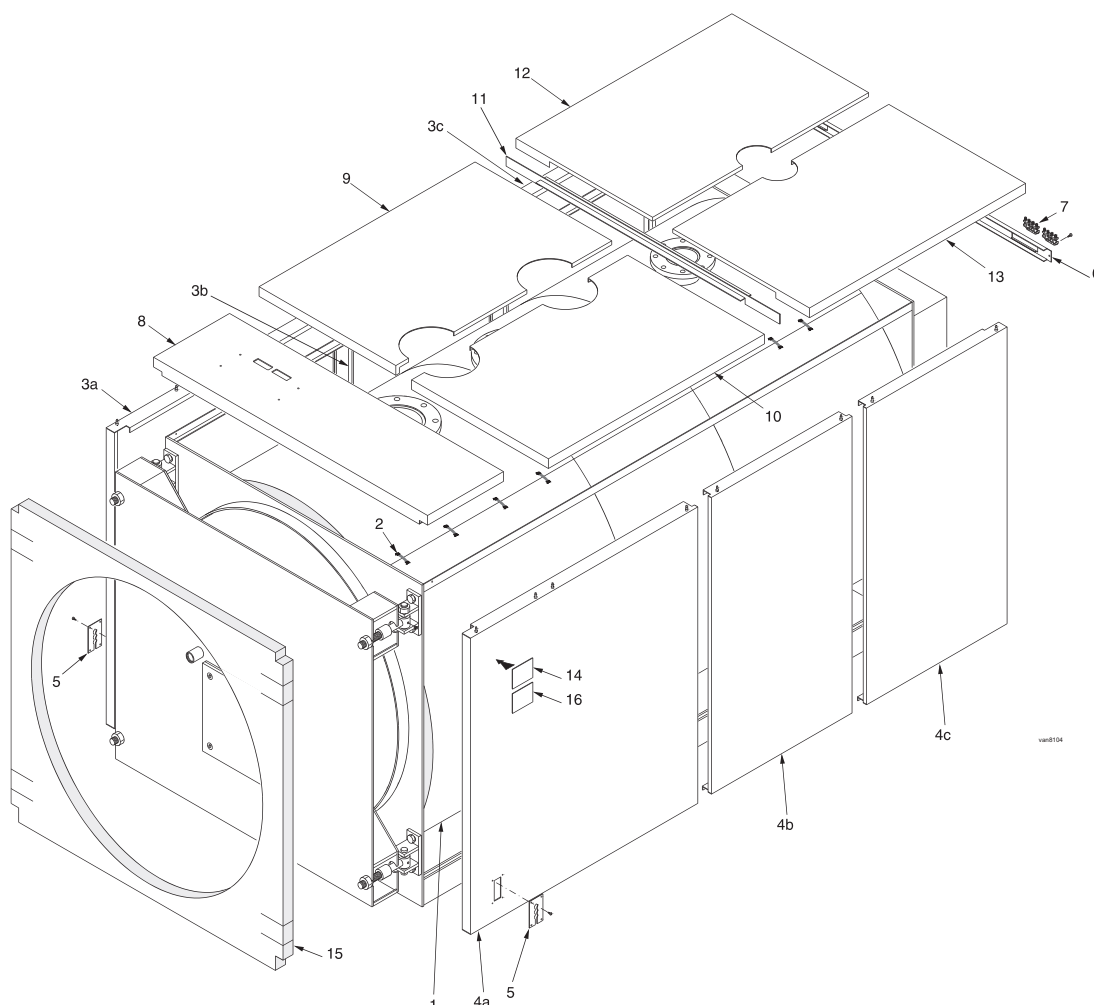

INSTALLATION

20 CASING ASSEMBLY

Vanguard L 3000 to 3500

For these boiler models the casing and insulation are contained in 3 cartons.

Assembly of the casing should be carried out in the following steps:

Refer to diagram below for details

- A.** Fit the insulation blanket (1) onto the boiler shell and secure in to place using the elasticated straps (2) provided, ensuring that the metal clips grip into the external surface of the insulation.

Make a convenient cut in the upper part of the insulation blanket to get easy access to the bulb holders.

- B.** Position the L.H. side panels (2 & 3) with the lower bend inside the bottom L profiles and hook them to the screws fitted to the upper square tube.

To determine which one of the front side panels is the left or the right ensure that the cable clamp plates (7) are positioned facing toward the front edge.

- C.** Position the R.H. side panels (6 and 3) with the lower bend inside the bottom L profiles and hook them to the screws fitted to the upper square tube.

To determine which one of the front side panels is the left or the right ensure that the cable clamp plates (7) are positioned facing toward the front edge.

- D.** Fit the control panel board to the left or right front side panel. Remove the upper shell of the control panel and insert the capillaries of the thermometer and thermostats through the slots.

- E.** Insert the thermometer and thermostat bulbs in the bulb holders as shown in Frame 22 and connect the mains, the burner, the pump(s) and any equipment to the control panel.

Refit the upper shell of the control panel.

Guide the burner plug through the side cable clamp plate (7) on the left or the right side opposite the burner door hinge and clamp the cable using the cable clamp supplied. Fix the side cable clamp plates (5) to the casing side panels (2 & 6).

- F.** Remove the protective paper film from data plate and ventilation requirement label (8 and 9) and fit them at the top front corner of the most accessible side panel after removal of dust from the surface.

Data plate and ventilation requirements label are in the plastic bag containing the documents.

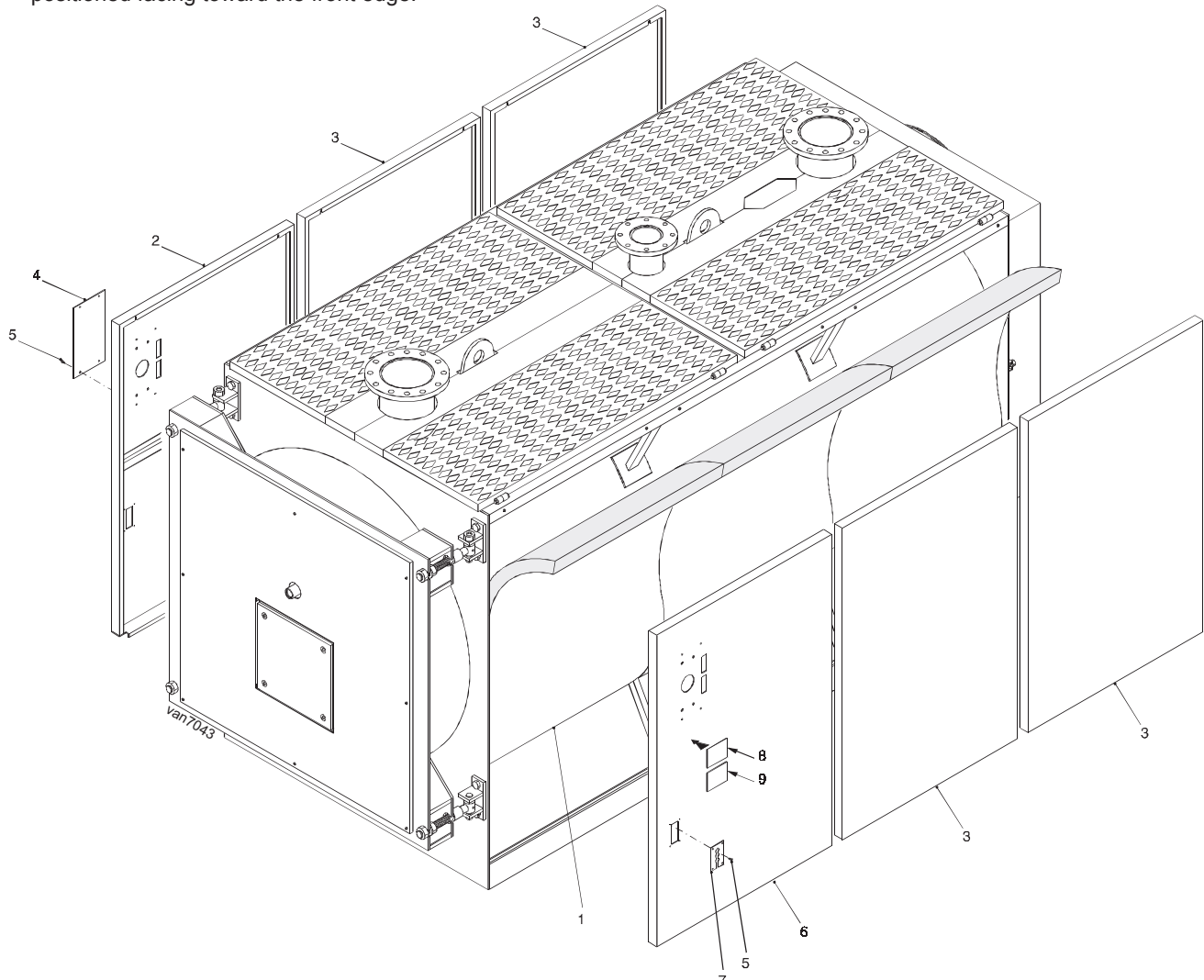

21 POSITION OF THE THERMOMETER/THERMOSTAT SENSORS IN THE BULB HOLDER

Vanguard L 1100 to 3500

Insert the sensors in the bulb holder in the upper part of the boiler, in the following order:

1. Thermometer
2. Operating (H/L) thermostat
3. Safety thermostat
4. Minimum thermostat

Ensure that the sensors are inserted to the bottom of the bulb holder and then secure them with the retaining clip (5).

In case some other thermostat is necessary, its sensors will be put in the 2nd bulb holder together with the contact spring (6) to improve the sensitivity.

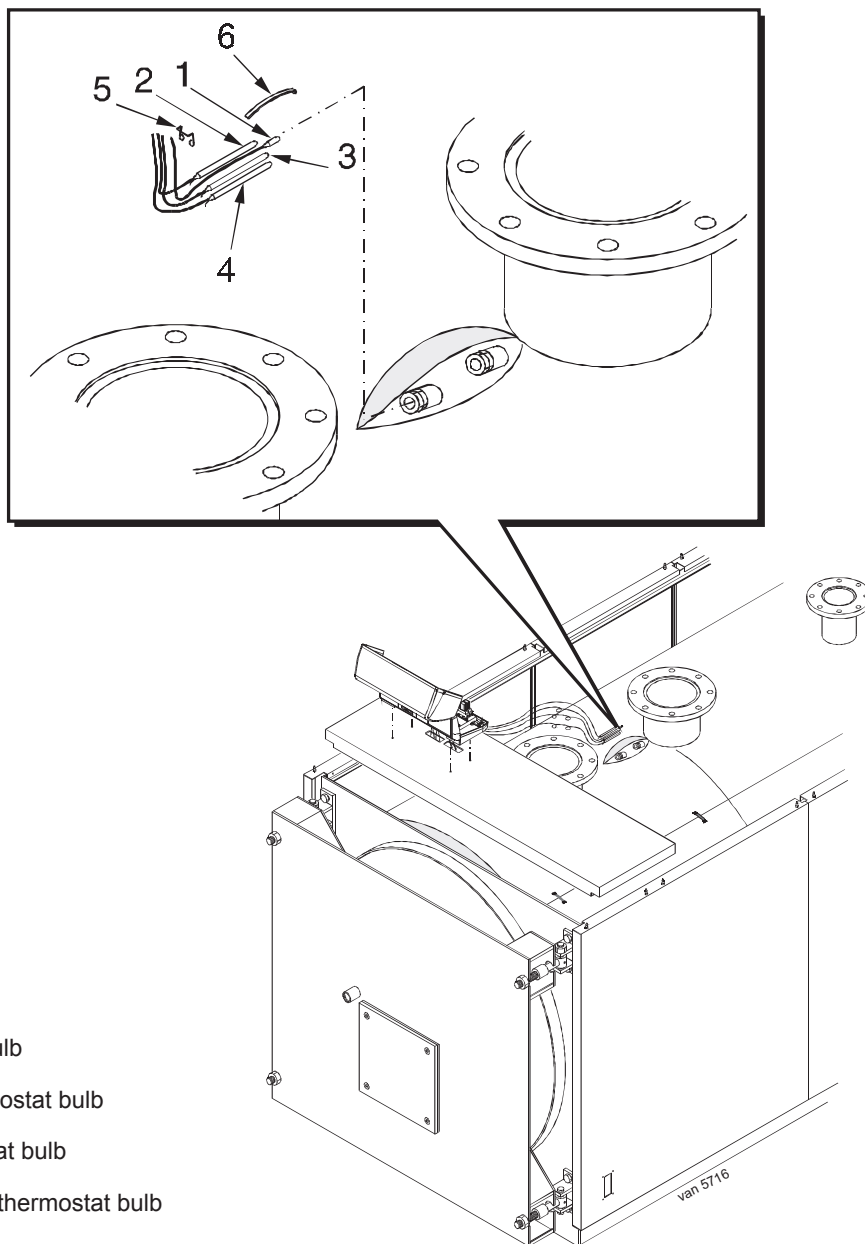

LEGEND

1. Thermometer bulb
2. Operation thermostat bulb
3. Safety thermostat bulb
4. Minimum temp. thermostat bulb
5. Sensor retaining clip
6. Contact spring

INSTALLATION

22 DOOR ASSEMBLY - VANGUARD L 170 to 630 MODELS

The combustion chamber door is fitted with four fixing points, two on the left hand side which are normally used as hinges.

The right hand side fixings are made with fastening bolts.

The door mounting can be reversed so that it hinges from left to right.

Door Adjustment

1. Vertical door adjustment: is possible only by adding washers of the right thickness under the hinge on which the door rotates.
2. Transverse door adjustment: is possible only by loosening the hinges fixed to the front tube plate of the boiler and moving them a little bit sideways.
3. Axial door adjustment: further adjustment to the position of the door in relation to the chamber can be achieved through adjustment of the screws.

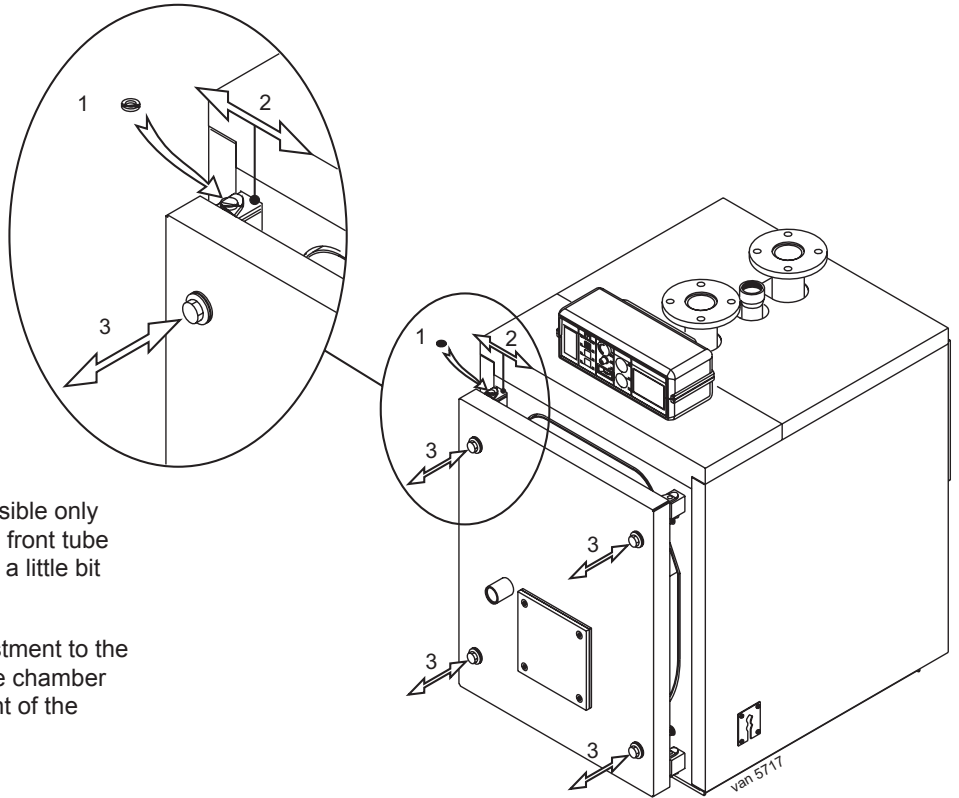

23 DOOR ASSEMBLY - VANGUARD L 170 to 630 MODELS

The combustion chamber door is fitted with four fixing points, two on the left hand side which are normally used as hinges.

The right hand side fixings are made with fastening bolts.

The door mounting can be reversed so that it hinges from left to right. However, when reversing the door the counter nuts will have to be moved from left to right, following the sequence shown 4, 5 and 6.

Door Adjustment

1. Vertical door adjustment: is possible by means of rotation of nut after removal of the grub screw.
2. Transverse door adjustment: is possible only by loosening the hinges fixed to the front tube plate of the boiler and moving them a little bit sideways.
3. Axial door adjustment: further adjustment to the position of the door in relation to the chamber can be achieved through adjustment of the nuts and counter nuts.

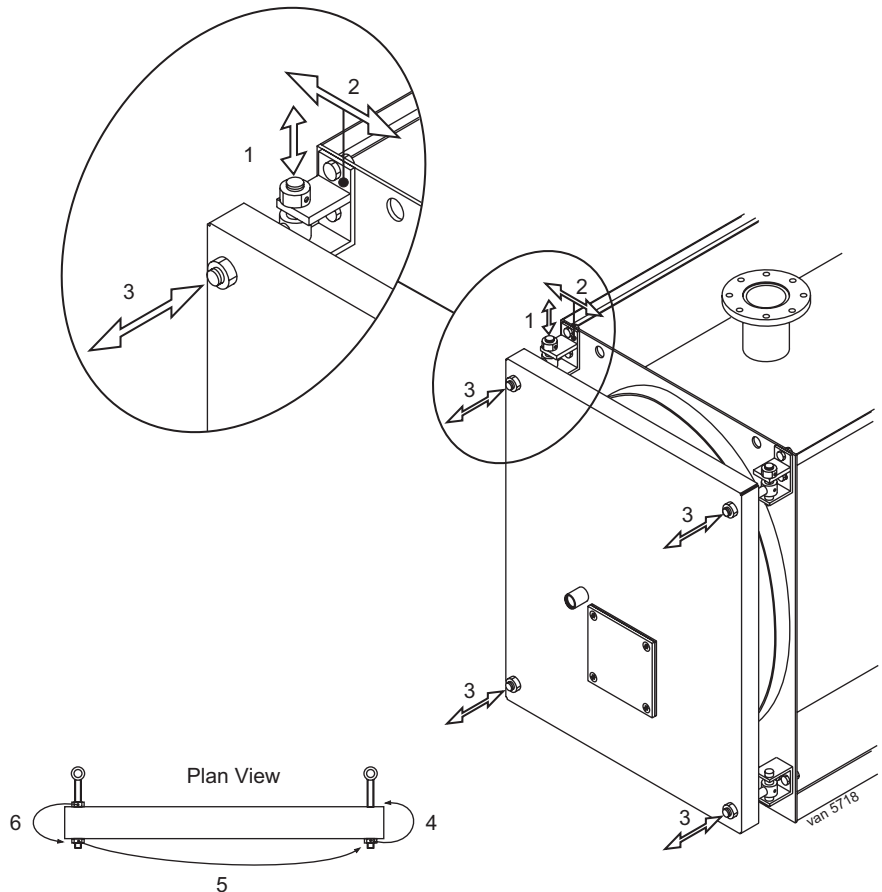

24 DOOR ASSEMBLY - VANGUARD L 1100 to 3500

The combustion chamber door is fitted with four fixing points, two on the left hand side which are normally used as hinges.

The right hand side fixings are made with fastening bolts.

The door mounting can be reversed so that it hinges from left to right. However, when reversing the door the bushing (9), nut (10) and washer (11) will have to be moved as shown below (details 1 and 3 for hinge side) (details 2 and 4 for hinge side).

Door Adjustment

1. Vertical door adjustment: is possible by means of rotation of nut after removal of the grub screw.
2. Transverse door adjustment: is possible only by loosening the hinges fixed to the front tube plate of the boiler and moving them a little bit sideways.
3. Further adjustment to the position of the door in relation to the chamber can be achieved through adjustment of the nuts (12) and counter nuts (10).

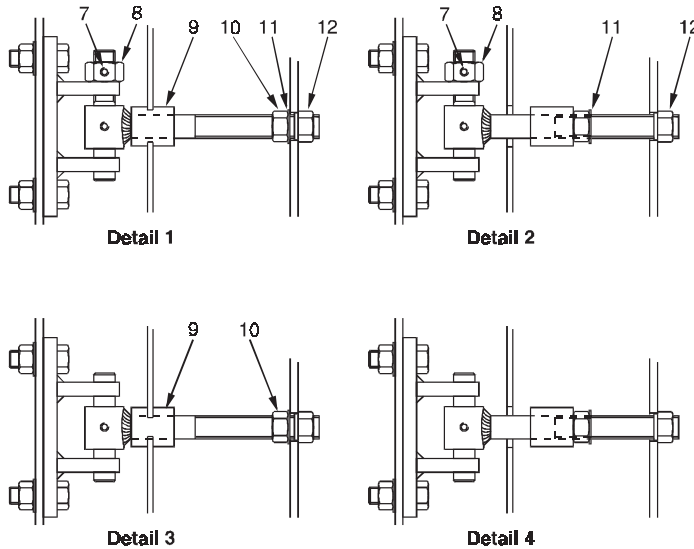
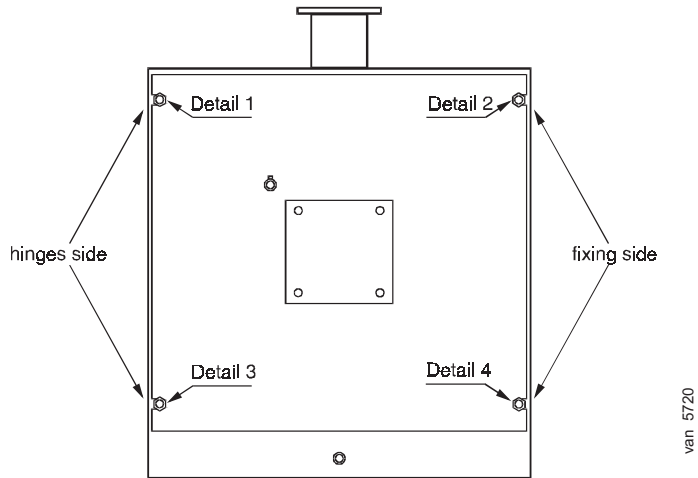
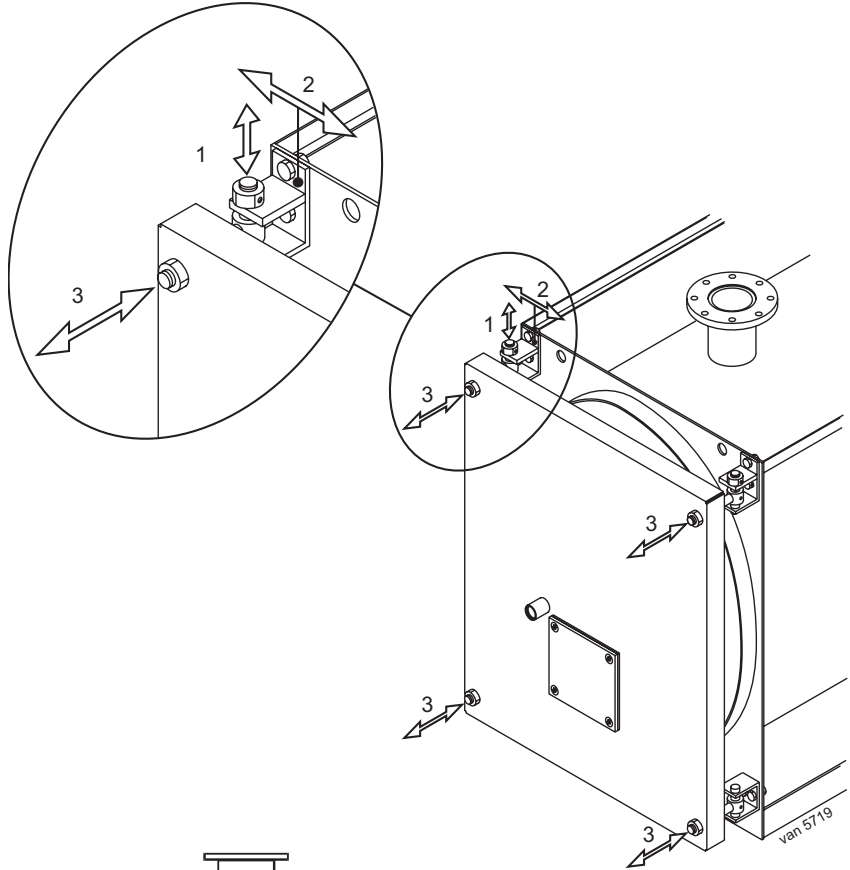

INSTALLATION

25 BURNER

The Vanguard boiler range is suitable for use with oil, gas, or dual fuel burners. Nuway, EOGB and Riello burners can be supplied as standard.

Burners from other manufacturers can be supplied on request.

Burners will be supplied for on/off or high/low operation.

Modulating burners can be supplied on request.

Burner Door

Burner doors have been pre-drilled to match the standard burners offered. Should another manufacturer's burner be used then it is the responsibility of the burner manufacturer to match the burner to the doors available.

Burner Mounting

When mounting the burner to the boiler front door, check for soundness around the burner flange and its gasket. Each boiler is supplied with a length of ceramic fibre rope (cross section 25x25 mm). This rope has to be put around the burner tube to completely seal the tube and the hole in the door insulation.

Gas Supply

The gas supply **MUST** be sized in accordance with British Gas recommendations and be prefabricated in compliance with CP 331 Pt 1 and any Local Gas Board installation standards.

The Local Gas Board should be contacted, at a stage prior to installation, for any advice or information required. Details and advice, relating to the use of L.P.G. for firing the Ideal Vanguard L range of boilers, are available on request to **Ideal**.

Oil Storage Tank

The oil storage tank, oil supply pipe and connections to the burner unit **MUST** comply with the requirements of BS 779 and CP 5410.

The installation should conform to the recognised standards of good practice in the trade and comply with the relevant Codes of Practice, Building Regulations and Local Authority, Fire and Insurance requirements.

26 FLAME INSPECTION

The Vanguard boiler range is provided with a sightglass tube placed above the burner door.

The sightglass tube has a thread (1) suitable for a pressure gauge and or for a cooling line (2) (not supplied) connection as shown in the diagram.

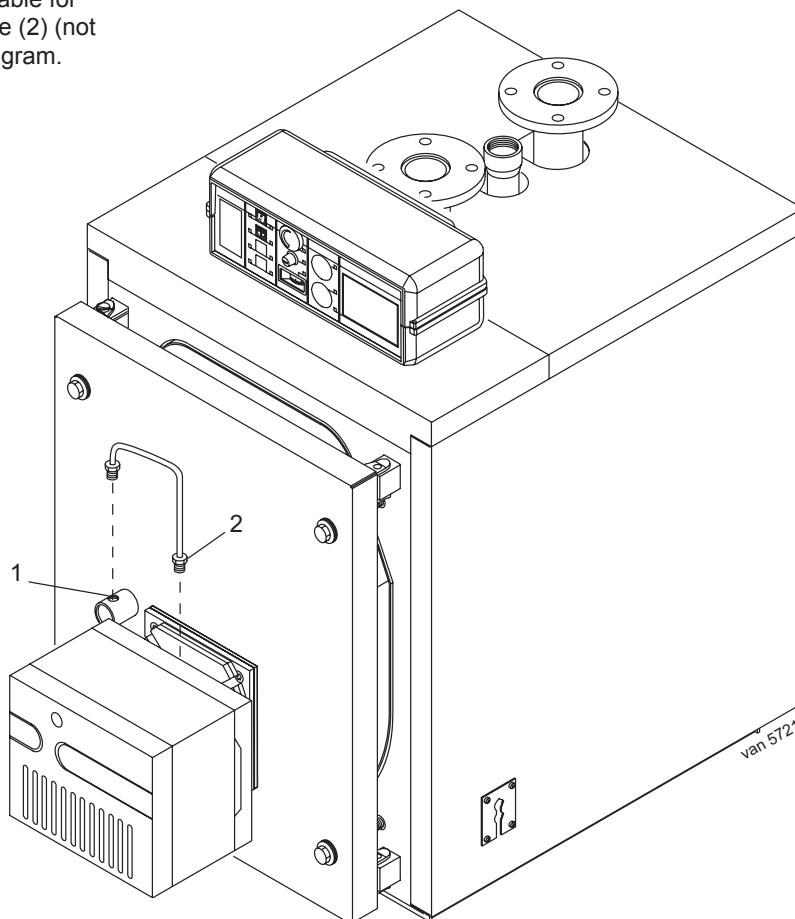

27 INTERNAL WIRING DIAGRAM

The control panel provided with the Vanguard L range is complete with a 7 way burner cable. A 4 way cable (for 2 stage burners) and the 7 and 4 pole plugs are in the literature pack.

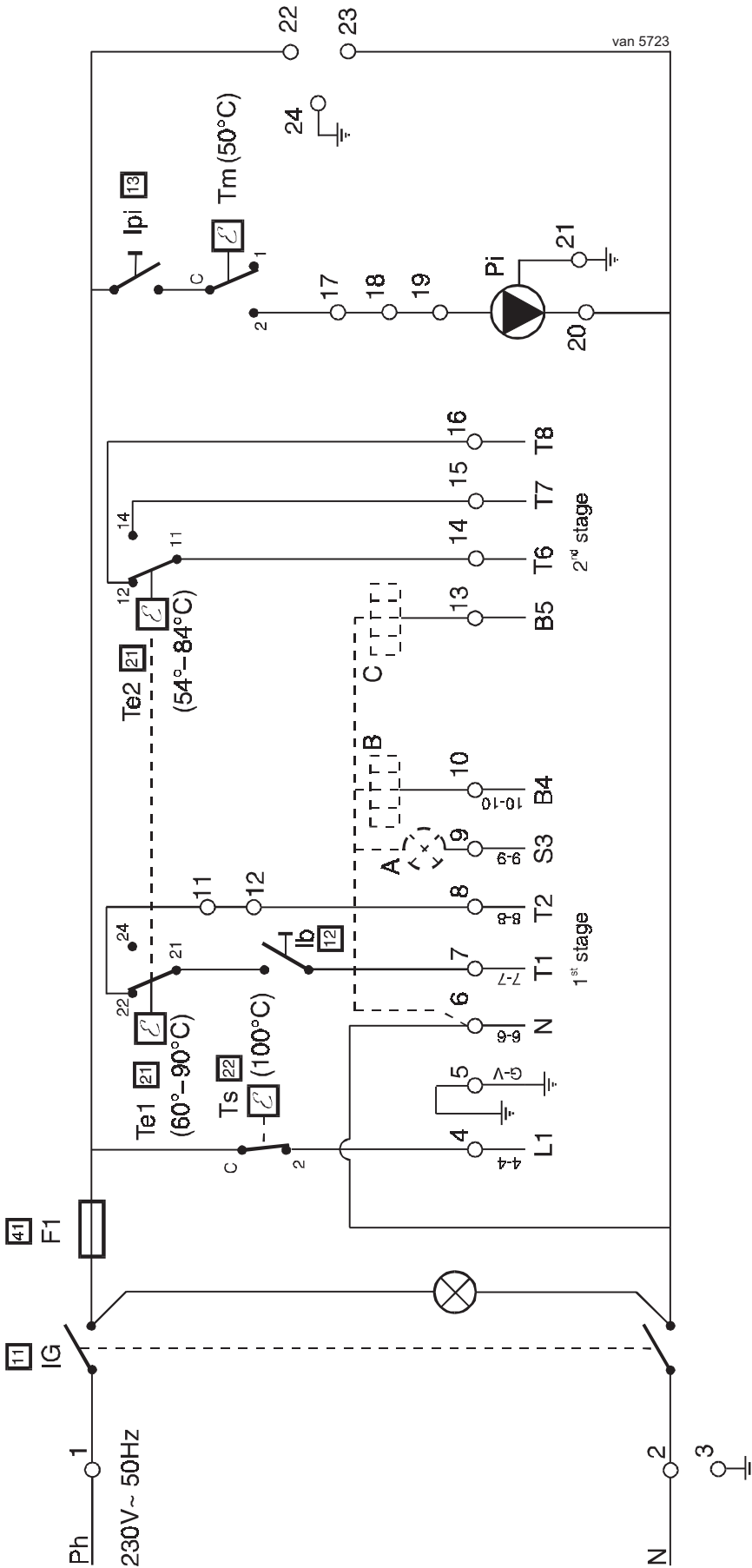

CONNECTIONS

- L1- LIVE
- ⊕- EARTH
- N- NEUTRAL
- T1]- CONTROLS LOCKOUT
- T2]- VALVE OPERATION
- S3]- 1st STAGE OPERATING LAMP
- B4]- 2nd STAGE OPERATING LAMP
- B5]- 2nd STAGE OPERATING LAMP
- T6]- 2nd STAGE OPERATING LAMP
- T7]- 2nd STAGE OPERATING LAMP
- T8]- 2nd STAGE OPERATING LAMP

COMPONENTS

- IG - Illuminated main switch
- F1 - Fuse
- Ipi - System pump switch
- Ib - Burner switch
- Pi - System pump (not supplied)
- A - Burner lock-out lamp (not supplied)
- B - Hour meter (not supplied)
- C - II stage hour meter (not supplied)
- Te1/Te2 - High/low regulating thermostat
- Tm - Minimum thermostat
- Ts - Safety thermostat with manual reset
- Not included

N.B.: With three-phase the motor must be connected directly; in this case the instrument panel feeds only the line of the auxiliaries of the burner. In case the burner is not provided with the connector, it will be necessary to follow the instructions in the burner instructions manual.

(*) - Disconnect the link between the terminals 11 and 12 of the terminal board prior to fitting a room thermostat (TA).

(**) - When the burner is not provided with connector complying with DIN 4791 norms connect the link between the terminals 4 and 7 of the terminal board. The room thermostat "TA" is to be connected to the pump in series.

INSTALLATION

28 WIRING HARNESS

The Burner control circuit may be fitted with 1 or 2 standard European connector-plugs (as supplied) and can be fitted directly to the burners fitted with connector-sockets. In the case of a burner not fitted with sockets, connect the leads to the terminal bar on the burner, proceeding as follows:

No (9) [1] Control circuit live interrupted in panel by Safety Thermostat TS and panel ON/OFF switch IG. Connect to the control circuit live terminal of burner.

Note.

The connector terminal for this control phase must be separate from those of the power supply phase(s) which are wired directly to the burner via the installer supplied burner mains relay.

No (8) [N] Neutral from control panel interrupted by panel ON/OFF switch. Connect to Neutral terminal of burner control box.

No (7) T1 Live feed from burner control circuit downstream of burner ON/OFF switch. Connect to live side of first stage control thermostat (High temperature setting).

No (6) T2 Return from 1st stage control thermostat (High temperature setting). Live on this lead, hence on T2 allows burner to fire on low fire in a 2 stage burner.

No (10) S3 Burner lockout indicator. Feeds signal from lockout terminal on burner control box to a remote lock out indicator.

No (4) B4 Feed to 1st stage operating indicator from burner low fire control. Indicates low fire in operation. Essentially feed back from live on (6) T2.

No (2) T6 Live feed from burner control circuit downstream of burner ON/OFF switch. Connects to live side of 2nd stage control thermostat (low setting thermostat).

No (3) T8 Return from 2nd stage control thermostat (low temperature setting). Live on this lead, hence on T8 allows burner to fire on high fire in a 2 stage burner.

No (5) T7 Back contact from 2nd stage control thermostat (low temperature setting). Live on this lead, hence T7 indicates high fire out of operation (used for modulating burners only).

No (1) B5 Feed to 2nd stage operating indicator from burner high fire control to boiler panel. Indicates high fire in operation. Essentially feed back from live on No (3) T8.

g/y Earth

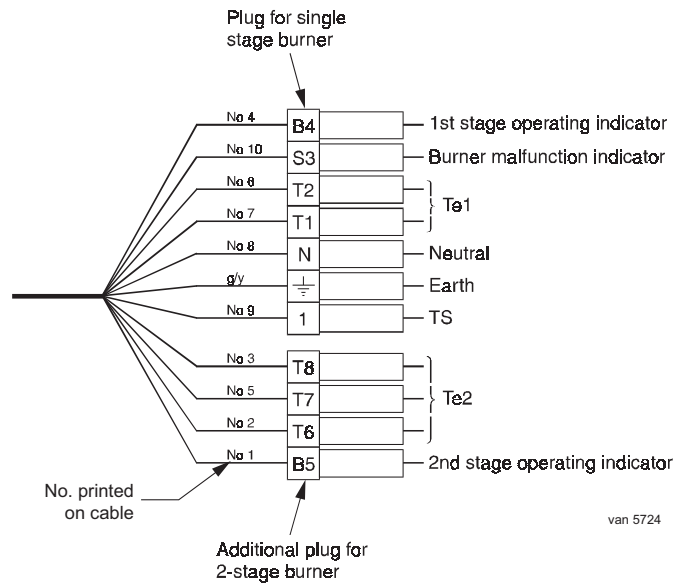

29 HEATING PUMP OVERRUN

The heating pump overrun is controlled by the minimum temperature thermostat.

30 FUEL OIL OR GAS CONNECTIONS

Refer to the instructions supplied with the burner.

31 COMMISSIONING AND TESTING

IMPORTANT. Domestic hot water circuits (if they exist) and heating circuits must have been filled and bled, and leak tightness tests must have been carried out on them, in accordance with the instructions for the domestic hot water calorifier (if existing) and boiler.

Refer to the following instructions to start up the boiler.

- the instructions delivered with the burner.
- the instructions delivered with the domestic hot water calorifier, (if existing).

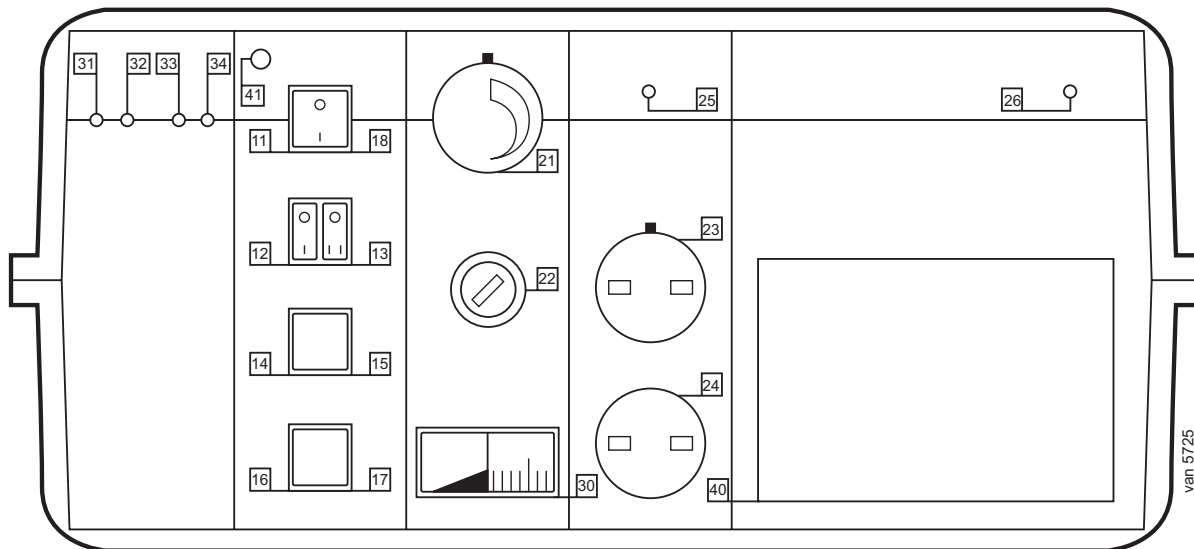

11. Boiler ON/OFF Switch (illuminated)
Position I . . ON. Position O . . OFF.

12. Burner Switch
Position I . . ON. Position O . . OFF.

13. Pump Switch
Position I I . . ON. Position O . . OFF.

21. Boiler ON/OFF, High/Low Thermostat
(High fire 54°C - 84°C, low fire 60°C - 90°C)

22. Boiler Safety Thermostat
(Set at 100°C) with manual reset.

24. Minimum Thermostat
(Set at 50°C) Controls the pump operation.

30. Thermometer
Indicator flow temperature.

41. Fuse
Rated at 4 amps.

Control of Water Temperature

The water temperature is controlled by the boiler thermostat (item 21). The temperature range of the thermostat is 50° - 90°C for ON/OFF operation. For boilers fitted with high/low burners the thermostat also incorporates a feature which automatically controls the burner changeover from high fire to low fire at a fixed 6° below the flow temperature setting (i.e. 44°C - 84°C).

INSTALLATION

32 POSITIONING OF THE TURBULATORS

The Vanguard L boilers are designed to be used in an output range to improve the seasonal efficiency and the possibility to be adopted in all the heating installations. The output must be adjusted at the commissioning stage, according to the system designer indications and, in any case, within the operation range for each boiler model shown on page 2, by the burner technician, which will determine the fuel throughput.

In any case the turbulators will be placed, inside the relevant smoke pipes, at a distance, from the front tube plate, as shown in the picture on the right.

When using the boiler at minimum output the smoke temperature will not be lower than 160°C.

In contrary case, before get in touch with our After Sale Service Dept. ascertain that the turbulators are in all the smoke pipes. The commissioning of the burner must be performed under the responsibility of a specialised and well trained burner technician, authorised by the burner manufacturer.

In that occasion a commissioning report has to be filled out.

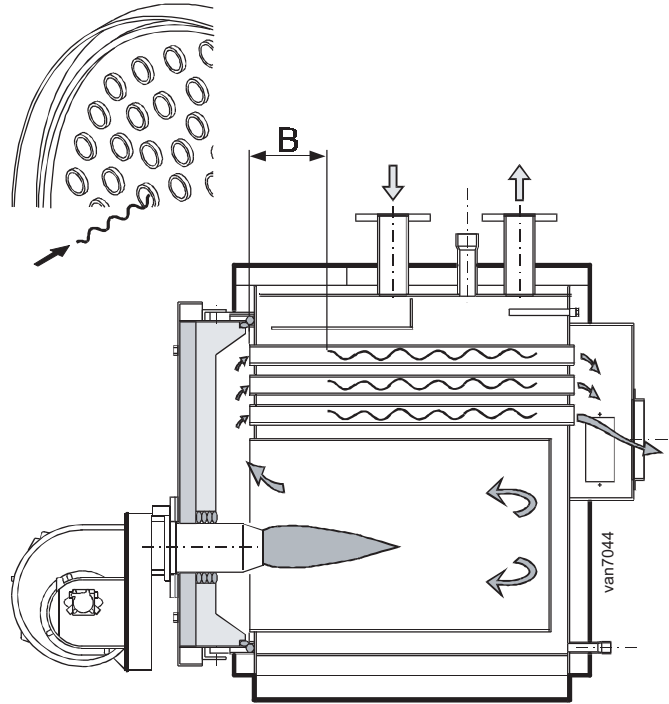

POSITION OF THE CORE INSIDE THE TURBULATOR (ONLY FOR MODELS VA L 170÷870)

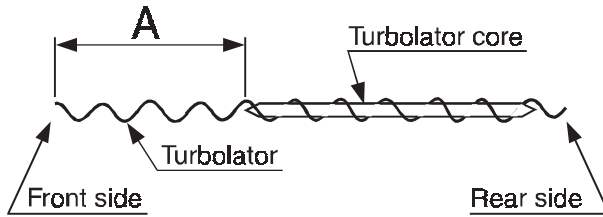

VA L 170	A =	50
VA L 240	A =	260
VA L 290	A =	200
VA L 340	A =	320
VA L 420	A =	390
VA L 510	A =	560
VA L 630	A =	700
VA L 760	A =	590
VA L 870	A =	810

Note: In the case of boiler use at minimum output, do not place the core inside the turbulator.

POSITION OF THE TURBULATORS INTO THE BOILER SMOKE PIPES

		At min. output	At max. output
VA L 170	B =	100	100
VA L 240	B =	100	100
VA L 290	B =	250	250
VA L 340	B =	200	200
VA L 450	B =	250	250
VA L 510	B =	200	200
VA L 630	B =	300	300
VA L 760	B =	330	330
VA L 870	B =	340	340
VA L 970	B =	370	370
VA L 1100	B =	200	200
VA L 1320	B =	410	310
VA L 1570	B =	910	750
VA L 1850	B =	1100	900
VA L 2200	B =	1290	1130
VA L 2650	B =	1470	1260
VA L 3000	B =	1540	1380
VA L 3500	B =	100	100

33 COMMISSIONING AND TESTING CONT'D

A. ELECTRICAL INSTALLATION

1. Checks to ensure electrical safety should be carried out by a competent person.
2. ALWAYS carry out the preliminary electrical system checks, i.e. earth continuity, polarity, resistance to earth and short circuit, using a suitable meter.

B. FOR GAS INSTALLATION

1. The whole of the gas installation, including the meter, should be inspected and tested for soundness and then purged in accordance with the recommendations of the relevant standards listed on page 4.

WARNING. Whilst effecting the required gas soundness test and purging air from the gas installation, open all windows and doors, extinguish naked lights and **DO NOT SMOKE.**

34 INITIAL LIGHTING

1. Check that the system has been filled and the boiler is not air locked - air in the boiler could damage the heat exchanger.
2. Check that all the drain cocks are closed and any valves in the flow and return are open.
3. Check that the GAS SERVICE COCK IS ON.
4. Unscrew the overheat reset button cap (22) and press the reset button.
5. Set the boiler thermostat (21) to maximum.
6. Switch the burner switch (12), and pump switch (13) to the ON position.
7. Switch the electricity supply ON and check that all the external controls are calling for heat. Set main boiler switch (11) to on.
8. The burner will commence the ignition sequence. If the burner has failed to light then it will lock out. Press the reset button to restart the ignition sequence.
9. Operate the boiler for 20 minutes and for gas fired boilers check the gas rate (Table 1).
10. Refer to the burner instructions for specific operating features.

35 GENERAL CHECKS

Make the following checks for correct operation.

1. The correct operation of ANY secondary system controls should be proved. Operate each control separately and check that the main burner or circulating pump, as the case may be responds.
 - a. With the system HOT examine all water connections for soundness.
 - b. With the system still HOT, turn off the gas or oil burner, water and electricity supplies to the boiler and drain down to complete the flushing process.
 - c. Refill and vent the system, clear all air locks and again check for water soundness.
 - d. Balance the system.
2. Water circulation system;
 3. Finally set the controls to the User's requirements.

36 HANDING OVER

ROUTINE OPERATION

Describe the function of the boiler and system controls and show how they are adjusted and used.

Hand these Installation and Servicing Instructions, User's Instructions and Log book to the customer and request him to keep them in a safe place for ready reference.

IMPORTANT. Point out the owner that the boiler must have regular maintenance and cleaning, at least annually, in order to ensure reliable and efficient operation. Regular attention will also prolong the life of the boiler and should preferably be performed at the end of the heating season.

Recommend that a contract for this work should be made with a Gas Safe Registered Engineer for gas fired boilers.

INSTALLATION

37 SYSTEM MAINTENANCE

Water Level

Check the water level in the installation regularly, and if necessary top it up without allowing a sudden inlet of cold water into the hot boiler.

The operation should only be necessary a few times per season; if it has to be done more frequently, there is probably a leak which should be found and corrected without delay.

Safety Devices

Check that safety devices, and particularly the heating circuit safety valve, are working correctly at regular intervals, and at least when the boiler is cleaned.

Draining

It is recommended that an installation should not be emptied unless absolutely necessary.

For example: when leaving for several months and/or there is a risk of frost in the building.

In the event of a long shutdown of the boiler we would recommend the following:

1. The boiler must be fully maintained.
2. IF the boiler is to be isolated during the winter period then we would advise that the system be treated with an antifreeze to prevent the heating water from freezing. Otherwise drain the system completely.

38 TURBULATORS REMOVAL

Detail 1:

Fit the brush handle extension onto the turbulator remover.
Withdraw the pin from turbulator.

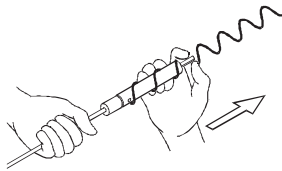

Detail 2:

Fit the pin in the radial hole with a hammer.

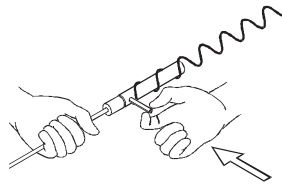

Detail 3:

Screw the turbulator remover onto the turbulator.

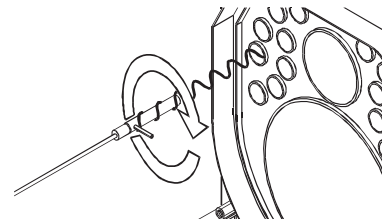

Detail 4:

Turn up to unblock the turbulator.

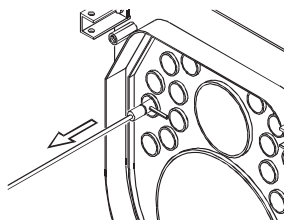

Detail 5:

Withdraw the turbulator.

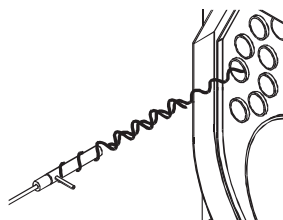

Detail 6:

Turn the remover counterclockwise to release the turbulator.

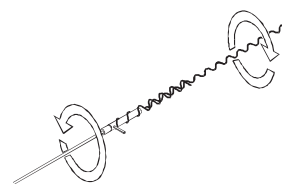

van7046

The procedure from detail 3 to 6 has to be repeated for all the turbulators.

39 SAFETY

For boilers with gas burners

It is the law that any service work must be carried out by a Gas Safe Registered Engineer.

WARNING. Always turn off the gas supply at the gas service cock, and switch off and disconnect the electricity supply to the appliance and any external controls before servicing.

IMPORTANT. After completing the servicing or replacement of components always:

- Test for gas soundness
- Check the water system is correctly filled and free of air. Air in the boiler could cause damage to the heat exchanger.
- With the system hot examine all water connections for soundness.
- Check the gas rate and measure the combustion CO/CO₂ content.
- Complete the boiler log book.
- Carry out functional checks as appropriate.

40 SERVICING SCHEDULE

To ensure the continued safe and efficient operation of the appliance it is recommended that it is checked at regular intervals and serviced as necessary. The frequency of servicing will depend upon the installation condition and usage but should be carried out at least annually.

Ideal does not accept any liability resulting from the use of unauthorised parts or the repair and servicing of appliances not carried out in accordance with the Company's recommendations and specifications.

1. Light the boiler and carry out function checks, noting any operational faults.
2. Run the boiler for 10 minutes and then check the burner rate.
3. Refer to the commissioning report or log book for the previous set up details and check for any changes.
4. Close off the fuel supply to the burner.
5. Ensure that the boiler has been cooled to ambient temperature.
6. Isolate the mains supply to the boiler and burner.
7. Open the combustion chamber door after disconnecting the supply pipe to the burner.
8. Remove the nuts and swing the burner door open to clean the burner. (Refer to burner manufacturers instructions)
9. Remove the turbulators.
10. Thoroughly clean the flue tubes and turbulators.
11. Remove the rear cleanout covers and dispose of the debris/soot that may have accumulated.
12. Replace the rear cleanout covers after first inspecting and if necessary replacing the seal.
13. Replace the flue turbulators into the flue tubes.
14. Check the condition of the combustion chamber door insulation.
15. Check the condition of the combustion chamber door seal.
16. Close the combustion chamber door.
17. Re-assemble the burner connections
18. After completion of servicing refer to previous frame for reference to final safety checks.
19. Complete the log book.

For additional fault finding advice please visit Ideal Heating's website

www.idealheating.com

Technical Training

The Ideal Heating Technical Training Centre offers a series of first class training courses for domestic, commercial and industrial heating installers, engineers and system specifiers. For details of courses please ring: 01482 498 432

Ideal Boilers, P.O. Box 103, National Ave, Kingston upon Hull, HU5 4JN. Telephone: 01482 492 251 Fax: 01482 448 858. Registration No. London 322 137.



Ideal Stelrad Group pursues a policy of continuing improvement in the design and performance of its products. The right is therefore reserved to vary specification without notice.



Ideal Stelrad Group

Ideal Installer/Technical Helpline: 01482 498 376

www.idealheating.com