

# installation and servicing

## Viceroy GTS

Your Ideal installation and servicing guide

**GTS 8, GTS 9, GTS 10, GTS 11,  
GTS 12, GTS 13 & GTS 14**

**300014487-001-C**

When replacing any part on this appliance, use only spare parts that you can be assured conform to the safety and performance specification that we require. Do not use reconditioned or copy parts that have not been clearly authorised by Ideal Boilers.

**i** BOILERS  
**Ideal**  
The High Efficiency Pioneers

# GENERAL

**Table 1 Performance Data**

Boiler		GTS8	GTS9	GTS10	GTS11	GTS12	GTS13	GTS14
Number of Sections		8	9	10	11	12	13	14
Maximum Heat Output	kW	390	450	540	600	670	720	780
	Btu/hx10 <sup>3</sup>	1330	1535	1842	2047	2286	2457	2661
Minimum Heat Output	kW	300	390	450	540	600	670	720
	Btu/hx10 <sup>3</sup>	1024	1330	1535	1842	2047	2286	2457
Hydraulic Resistance at 11k	mbar	31.6	49.3	75.9	84.2	104.9	127.9	161.4
	in w.g.	12.6	19.7	30.3	33.7	42.0	51.2	64.6
Hydraulic Resistance at 20k	mbar	9.6	14.9	23.0	25.5	31.7	38.7	48.8
	in w.g.	3.8	6.0	9.2	10.2	12.7	15.5	19.5
Combustion Chamber Resistance (at zero draught)	mbar	1.1	1.5	2.0	2.5	2.5	2.5	3.5
	in w.g.	0.44	0.6	0.8	1.0	1.0	1.0	1.4
Minimum Draught at Smokehood Outlet (for max. output)	mbar	0	0	0	0	0	0	0
	in w.g.	0	0	0	0	0	0	0

## Oil

Maximum Oil Rate	l/h	43.08	49.76	59.51	66.42	74.17	79.71	86.35
	gal/h	9.48	10.95	13.09	14.61	16.32	17.54	19.00
Maximum Flue Gas Volume	m <sup>3</sup> /s	0.252	0.290	0.348	0.387	0.432	0.465	0.503
	ft <sup>3</sup> /min	534	614	737	820	915	985	1065
Flue Gas CO <sub>2</sub> / Temperature	% / °C	13 / 220	13 / 220	13 / 220	13 / 220	13 / 220	13 / 220	13 / 220

## Gas

Maximum Gas Rate	m <sup>3</sup> /h	44.78	51.74	61.88	69.06	77.11	82.87	89.77
	ft <sup>3</sup> /h	1582	1827	2185	2439	2723	2927	3170
Maximum Flue Gas Volume	m <sup>3</sup> /s	0.279	0.322	0.386	0.429	0.479	0.515	0.558
	ft <sup>3</sup> /min	591	682	818	909	1015	1091	1182
Flue Gas CO <sub>2</sub> / Temperature	% / °C	9.5 / 220	9.5 / 220	9.5 / 220	9.5 / 220	9.5 / 220	9.5 / 220	9.5 / 220

**Table 2 General Data**

Flow Connection	in.	3	3	3	4	4	4	4
Return Connection	in.	3	3	3	4	4	4	4
Drain Connection	in.	2	2	2	2	2	2	2
Maximum Operating Pressure	bar	6	6	6	6	6	6	6
Boiler Thermostat Setting	°C	30-90	30-90	30-90	30-90	30-90	30-90	30-90
Safety Thermostat Setting	°C	110	110	110	110	110	110	110
High / Low Setting	°C	30-90	30-90	30-90	30-90	30-90	30-90	30-90
Nominal Flue Diameter	m m	250	250	250	300	300	300	300
	in.	10	10	10	12	12	12	12
Boiler Water Content	l	366	409	452	495	538	581	624
	gal	80.5	89.9	99.4	109	118.4	127.8	137.3
Boiler DRY Weight less Burner Unit	kg	1802	2072	2238	2454	2638	2880	3057
	lb	3972.5	4568	4934	5410	5816	6349.5	6739.5

## Note.

*Fuel rates and flue gas data relate to maximum output ratings.*

*Gas firing data relates to the use of NATURAL GAS ONLY.*

*Details for the use of LPG are available on request from Ideal Stelrad Group.*

*Natural gas consumption is calculated using a calorific value of 38.7MJ/m<sup>3</sup> (1038Btu/ft<sup>3</sup>) gross or 34.9MJ/m<sup>3</sup> (935Btu/ft<sup>3</sup>) nett at 15°C and 1013.25mbar.*

*Oil rates relate to Gas Oil using a calorific value of 45.56 MJ/kg gross or 42.69 MJ/kg nett.*

## HEALTH & SAFETY DOCUMENT NO. 635

**The electricity at work regulations, 1989.** The manufacturer's notes must NOT be taken, in any way, as overriding statutory obligations.

**IMPORTANT.** These appliances are CE certified for safety and performance. It is, therefore, important that no external control devices, e.g. flue dampers, economisers etc., are directly connected to these appliances unless covered by these Installation and Servicing Instructions or as otherwise recommended by **Ideal Stelrad Group** in writing. If in doubt please enquire.

Any direct connection of a control device not approved by **Ideal Stelrad Group** could invalidate the certification and the normal appliance warranty. It could also infringe the Gas Safety Regulations and the above regulations.

## CONTENTS

Assembly.....	13-26
Boiler Clearances.....	7
Burner Connection.....	13
Commissioning and Testing.....	30,31
Electrical Connections.....	27
Electrical Supply.....	5
Flue Installation.....	5
Fluing.....	12
Gas Safety Regulations.....	4
Gas Supply.....	4
Hydraulic Resistance.....	2
Initial Lighting.....	31
Introduction.....	3
Installation.....	13
Option Kits.....	3
Performance Data.....	2
Servicing.....	32,33
Ventilation.....	8
Water Circulation.....	5
Water Connections.....	8
Water System Requirements.....	9
Water Treatment.....	5
Wiring Diagram.....	28

## Viceroy GTS

Gas and Fuel Oil

P. I. No.: 1312AQ 952

Destination Countries: GB, IE

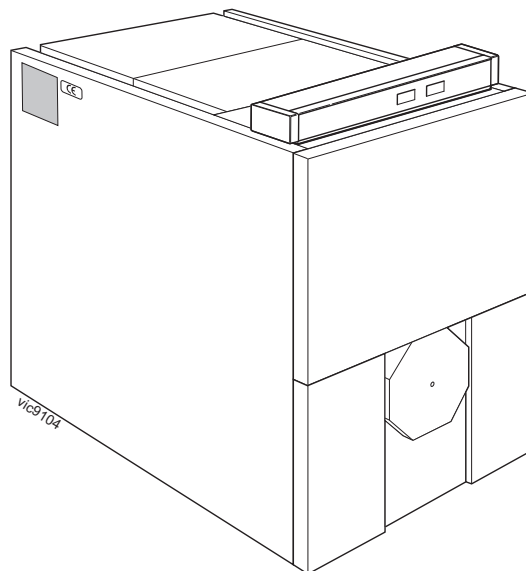

## INTRODUCTION

The Viceroy GTS boilers are a range of cast iron sectional pressure jet boilers offering high efficiency operation, ease of maintenance, fuel flexibility and low emissions. Suitable for oil or gas operation the Viceroy GTS range is supplied in a choice of 7 standard models, rated in outputs from 300kW (1,024,000 Btu/h) to 780kW (2,661,000 Btu/h) and has a maximum operating pressure of 6 bar. All models may have high/low operation.

Designed with a large combustion chamber, 3 pass horizontal flue ways incorporating fins and cast iron turbulators, the Viceroy GTS ensures maximum heat transfer efficiency.

The boilers are suitable for: combined indirect pumped domestic hot water and central heating systems; independent indirect pumped domestic hot water or central heating systems.

Fully pumped systems may be open vented or sealed.

The boilers are NOT suitable for:

1. Gravity DHW systems
2. Gravity heating systems
3. Direct domestic hot water supply

### Options

Flue Gas Thermometer (ID28)

**CAUTION.** To avoid the possibility of injury during the installation, servicing or cleaning of this appliance, care should be taken when handling edges of sheet steel components.

## SAFETY

### Current Gas Safety (Installation and Use) Regulations or rules in force.

It is law that all gas appliances are installed and serviced by a CORGI registered installer in accordance with the regulations below. Failure to install appliances correctly could lead to prosecution. It is in your own interest, and that of safety, to ensure the law is complied with.

The following must be conformed with:

Current Building Regulations and Clean Air Act

Water Authority Regulations

Local Authority Regulations and Regional Bylaws

Gas Safety Regulations

Any special regional requirements of local Electricity and Gas undertaking.

Fire Service and Insurance Company requirements.

In the interests of safety, a competent installer should be employed to effect the installation of the appliance. Manufacturer's notes must NOT, in any way, be taken as over riding statutory obligations.

The installation of the boiler MUST also be in accordance with the latest I.E.E. (BS7671) Wiring Regulations, local buildings regulations, bye-laws of the local water authority, the building regulations and the Building Standards (Scotland) and any relevant requirements of the local authority.

Detailed recommendations are contained in the following Codes of Practice:

<b>BS 799 Pt4 &amp; 7</b>	Oil burning equipment.
<b>BS 799 Pt5</b>	Oil storage tanks.
<b>BS 5410 Pt1</b>	Installation for space heating and hot water supply.
<b>BS 5854</b>	Flues and flue structures in buildings.
<b>BS 5885 Pt1</b>	Gas burners - with inputs 60kW and above.
<b>BS 6644</b>	Installation of gas fired hot water boilers of rated input between 70kW and 1.8MW (net) (2nd and 3rd family gases).
<b>BS 6880</b>	Low temperature hot water heating systems of output greater than 45kW.
Part 1	Fundamental and design considerations
Part 2	Selection of equipment.
Part 3	Installation, commissioning and maintenance.
<b>BS 6891</b>	Installation of low pressure gas pipework of up to 28mm (R1) in domestic premises (2nd family gas).
<b>EN 303.1</b>	Heating boilers with forced draught burners. General requirements.

<b>EN 303.2</b>	Heating boilers with forced draught burners with atomising oil burners.
<b>EN 304</b>	Test code for heating boilers for atomizing oil burners.
<b>73/23 EEC</b>	Low voltage directive. (Relevant standard is EN60335.1)
<b>89/336 EEC</b>	Electromagnetic Compatibility Directive. (Relevant standards are EN50081.1, EN50082.1 and EN55014.)
<b>90/396 EEC</b>	Gas Appliance Directive. (Relevant standards are EN303.1, EN303.2 and EN304.)
<b>92/42 EEC</b>	Boiler Efficiency Directive.
<b>IGE/UP/1</b>	Soundness testing and purging of industrial and commercial gas installation.
<b>IGE/UP/2</b>	Gas installation pipework, boosters and compressors on industrial and commercial premises.
<b>IGE/UP/10</b>	Installation of gas appliances in industrial and commercial premises.

## SAFE HANDLING OF SUBSTANCES

Care should be taken when handling the boiler insulation panels, which can cause irritation to the skin. No asbestos, mercury or CFCs are included in any part of the boiler or its manufacture.

## GAS SUPPLY

The local gas supplier should be consulted, at the installation planning stage, in order to establish the availability of an adequate supply of gas. An existing service pipe must NOT be used without prior consultation with the local gas supplier.

A gas meter can only be connected by the local gas supplier or by a registered CORGI engineer.

An existing meter should be checked, preferably by the gas supplier, to ensure that the meter is adequate to deal with the rate of gas supply required. A minimum working gas pressure of 17.5mbar MUST be available at the boiler inlet for Natural gas and 37mbar for Propane.

Do not use pipes of smaller size than the burner inlet gas connection.

The complete installation MUST be tested for gas soundness and purged in accordance with the appropriate standards listed on page 4.

### Gas Boosters

A gas booster is required if the gas pressure available at the burner is lower than that required by the burner manufacturer to attain the flow rate for maximum burner input rating.

Location of the booster requires careful consideration but should preferably be closer to the burner rather than the gas meter. Ventilation should also be considered to ensure ambient temperatures do not exceed designed recommendations. Further guidance is provided in IGE/UP/2 as listed above.

**Assembly and Installation Instructions for Ideal Viceroy GTS heating boilers should be read in conjunction with the general technical data tables enclosed and any other technical publication supplied with the burner.**

**NOTE TO THE INSTALLER: LEAVE THESE INSTRUCTIONS ADJACENT TO THE BOILER**

## FLUE INSTALLATION

### IMPORTANT

It is the responsibility of the installer to ensure, in practice, that products of combustion discharging from the terminal cannot re-enter the building or any other adjacent building through ventilators, windows, doors, other sources of natural air infiltration, or forced ventilation / air conditioning.

If this should occur the appliance **MUST** be turned OFF, labelled as 'unsafe' and corrective action taken.

The flue must be installed in accordance with the appropriate standards listed on page 4.

## WATER CIRCULATION SYSTEM

The system pump **MUST** be connected to the boiler.

The boiler must **NOT** be used for direct hot water supply. The hot water storage cylinder **MUST** be of the indirect type.

The appliances are **NOT** suitable for gravity central heating nor are they suitable for the provision of gravity domestic hot water.

The hot water cylinder and ancillary pipework, not forming part of the useful heating surface, should be lagged to prevent heat loss and any possible freezing - particularly where pipes run through roof spaces and ventilated underfloor spaces.

The boiler must be vented.

Draining taps **MUST** be located in accessible positions, which permit the draining of the whole system - including the boiler and hot water storage vessel. They should be at least 1/2" BSP nominal size and be in accordance with BS. 2879.

The central heating system should be in accordance with the relevant standards listed on page 4.

Due to the design of the boiler the heat stored within the castings at the point of shutdown of the burner must be dissipated in order to avoid overheating. In order to allow pump operation after burner shutdown the boiler control system should incorporate a pump overrun device.

## WATER TREATMENT FOR HOT WATER AND HEATING BOILERS

There is a basic need to treat the water contained in all heating and indirect water systems, particularly open vented systems. It is assumed, incorrectly, that because boilers are operating in conjunction with what is apparently a closed circuit an open vented system will not, under normal circumstances, allow damage or loss of efficiency due to hardness salts and corrosion once the initial charge of water has been heated up a few times.

1mm of lime reduces the heat transfer from metal to water by 10%.

In practice the deposition of these salts is liable to cause noises from the boiler body or even premature boiler failure. Corrosion and the formation of black iron oxide sludge will ultimately result in premature radiator failure.

Open vented systems are not completely sealed from the atmosphere if proper venting and expansion of system water is to be achieved. The same tank is used to fill the system with

water and it is through the cold feed pipe that system water expands into the tank when the boiler passes heat into the system.

Conversely, when the system cools, water previously expelled is drawn back from the tank into the system together with a quantity of dissolved oxygen.

Even if leakage from the heating and hot water system is eliminated there will be evaporation losses from the surface of the tank which, depending upon ambient temperature, may be high enough to evaporate a large portion of the system water capacity over a full heating season.

There will always be corrosion within a heating or hot water system to a greater or lesser degree, irrespective of water characteristics, unless the initial fill water from the mains is treated. Even the water in closed systems will promote corrosion unless treated. For the reason stated, **Ideal Stelrad Group** strongly recommend that when necessary the systems is thoroughly cleaned, prior to the use of stable inhibitor, which does not require continual topping up to combat the effects of hardness salts and corrosion on the heat exchangers of the boiler and associated systems.

**Ideal Stelrad Group** advise contact directly with specialists on water treatment such as:

GE Betz Ltd, Sentinel Division, Foundry Lane,  
Widnes, Cheshire, WA8 8UD,  
Tel: +44 (0) 151 424 5351

Fernox Manufacturing Co. Ltd., Cookson Electronics,  
Forsyth Road, Sheerwater, Woking, Surrey, GU21 5RZ  
Tel: +44 (0) 799 521 133

## ELECTRICAL SUPPLY

**WARNING** This appliance must be earthed.

The control system requires a 230V - 50Hz mains supply.

Wiring external to the appliance **MUST** be in accordance with the current I.E.E. (BS7671) Wiring Regulations and any local regulations which apply.

### Burner and Pump

These may be 1ph or 3ph. Refer to manufacturer's instructions.

The point of connection to the mains should be readily accessible and adjacent to the boiler.

## LOCATION OF THE BOILER

The boiler must stand on a non-combustible floor (i.e. concrete or brick) which must be flat, level and of a suitable load bearing capacity to support the weight of the boiler (when filled with water) and any ancillary equipment.

If the boiler is mounted on a plinth then the dimensions must exceed the plan area of the boiler by at least 75mm on each side.

The boiler must not be fitted outside.

# GENERAL

## 1 BOILER DIMENSIONS

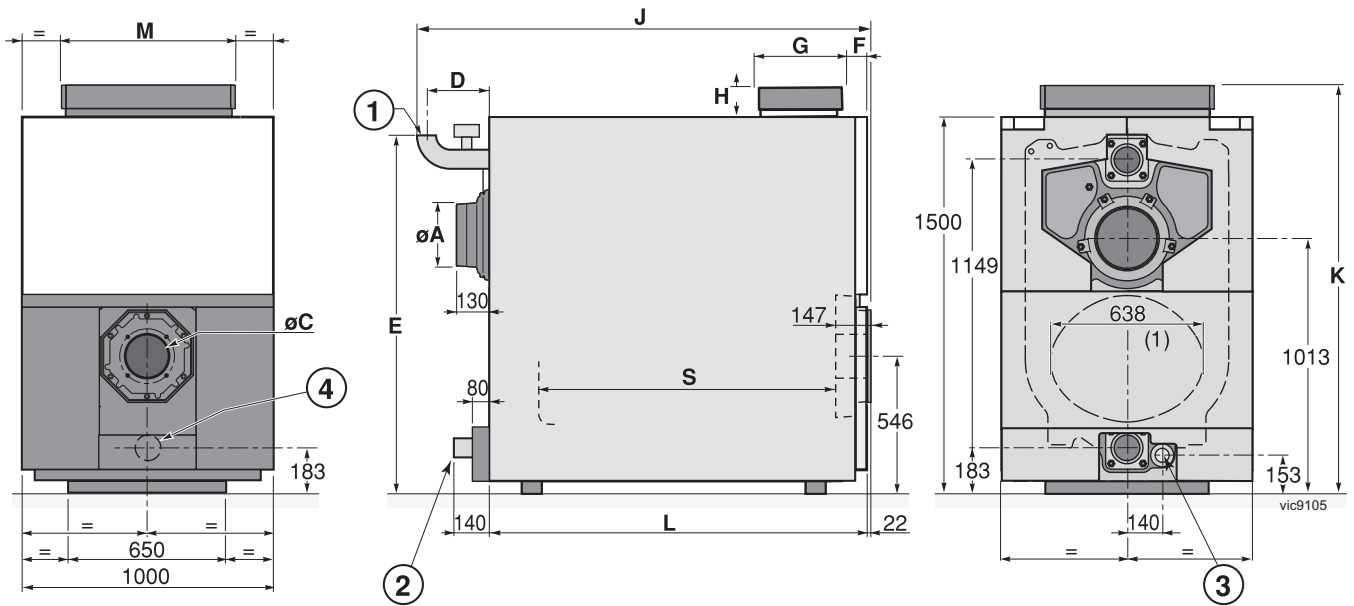

Internal diameter (mm)

- Front section : 455
- Intermediate section : 530

Equivalent diameter (mm) : 573

Mk : Tapped connection

- ① Heating outlet - weld
- ② Heating return - weld
- ③ Rp 2 draining outlet - plugged
- ④ Sludge removal hole Ø Rp 2 1/2 - plugged

Boiler	GTS 8	GTS 9	GTS 10	GTS 11	GTS 12	GTS 13	GTS 14
Ø A (outside dia)	250	250	250	300	300	300	300
Ø B	3"	3"	3"	4"	4"	4"	4"
Ø C	Ø 135 - 175 - 190 - 240 - 250 - 290 or plain plate						
D	235	235	235	254	254	254	254
E	1427	1427	1427	1447	1447	1447	1447
J	1800	1950	2120	2305	2465	2625	2785
L	1505	1665	1825	1985	2145	2305	2465
S	1183	1343	1503	1663	1823	1983	2143
F	127.5	127.5	127.5	127.5	127.5	127.5	127.5
G	130	130	130	130	130	130	130
H	105	105	105	105	105	105	105
K	1605	1605	1605	1605	1605	1605	1605
M	738	738	738	738	738	738	738



### 3 VENTILATION

Safe, efficient and trouble-free operation of conventionally flued gas boilers is vitally dependent on the provision of an adequate supply of fresh air to the room in which the appliance is installed.

Ventilation by grilles communicating directly with the outside air is required at both high and low levels. The minimum free areas of these grilles must be according to the following scale:

**Required area (cm<sup>2</sup>) per kW of total rated input (net)**

	Boiler room	Enclosure
Low level (inlet)	4	10
High level (outlet)	2	5

Note: Where a boiler installation is to operate in summer months (e.g. DHW) additional ventilation requirements are stated, if operating for more than 50% of time (refer to BS6644).

Position ventilation grilles to avoid the risk of accidental obstruction by blockage or flooding. If further guidance on ventilation is required then consult BS 6644.

The supply of air by mechanical means to a space housing the boiler should be by mechanical inlet with natural or mechanical extraction. Mechanical extract ventilation with natural inlet must not be used.

Where a mechanical inlet and a mechanical extract system is applied, the design ventilation flow rates should be as in BS 6644.

**Note.**

*For mechanical ventilation systems an automatic control should be provided to cause safety shutdown or lockout of the boiler(s) in the event of failure of air flow in either inlet or extract fans.*

**IMPORTANT.** The use of an extractor fan in the same room as the boiler (or in an adjacent communicating room) can, in certain conditions, adversely affect the safe operation of the boiler.

Where such a fan is already fitted (or if it is intended to fit an extractor fan after installation of the appliance) the advice of the gas supplier should be obtained.

The temperature within a boiler room shall not exceed 25°C within 100 mm of the floor, 32°C at mid height and 40°C within 100 mm of the ceiling.

### 4 BOILER WATER CONNECTIONS

Flow and return connections are positioned at the rear of the boiler.

The flow and returns are provided with stub pipes sized as in Table 2.

A 2" drain connection is provided at the bottom of the boiler rear section.

A 2 1/2" connection is provided for sludge removal at the bottom of the boiler front section.

#### DE-SLUDGE CONNECTION

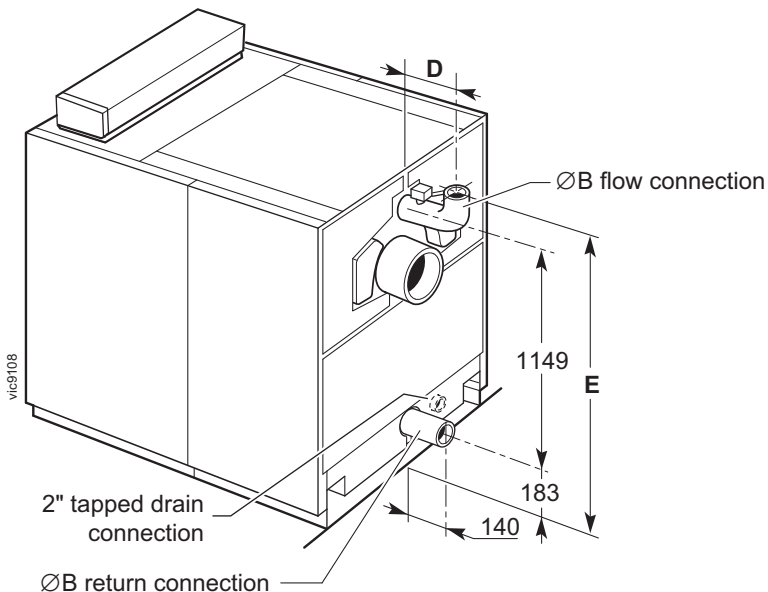
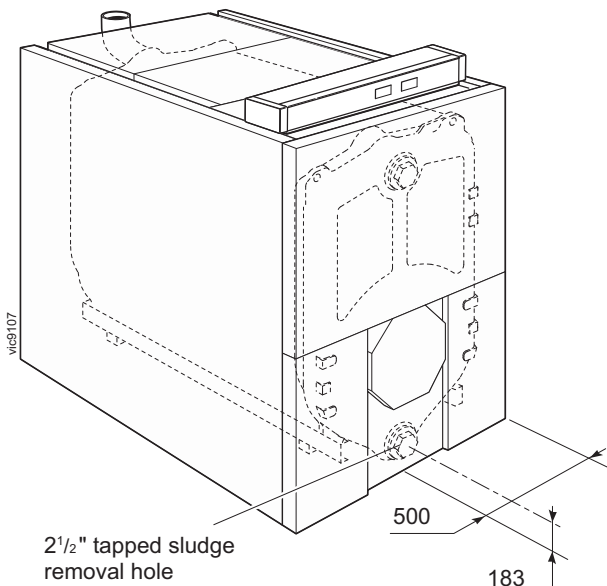

Boiler	GTS 8, 9, 10	GTS 11, 12, 13, 14
Ø B	3"	4"
D mm	235	254
E mm	1427	1447

## 5 FILLING THE SYSTEM

Filling shall be performed with a low flow rate from a low point in the boiler room in order to ensure that all the air in the boiler is bled from the high point of the system.

Always stop the pump before filling.

**IMPORTANT.** Instructions for starting up the boiler for the first time after the system is fully or partly drained:

If all the air is not bled naturally to an expansion tank which is open vented, the system must include manual bleed valves, in

addition to automatic air vents which bleed the system when it is operating. The manual bleed valves are used to bleed all the high points of the system and to make sure that the filled system is free of air before the burner is turned on.

### General

Recommendations relating to the water system are contained in BS. 6880.

## 6 OPEN VENTED SYSTEM REQUIREMENTS - minimum static head requirements

The Viceroy GTS boiler has a minimum static head requirement of 2.5 metres (8 feet approx.) depending on the particular characteristics of the system design (see diagram). The information provided is based on the following assumptions.

1. An open vent/safety pipe connection is made immediately after the flow connection.
2. A cold feed/expansion pipe connection is made to the system return pipe within 0.75m of the boiler return connection.
3. The maximum flow rate through the boiler is based on a temperature difference of 11°C (20°F) at full boiler output with the circulating pump positioned in the flow of the system.
4. The boiler is at the highest point of the system. Systems designed to rise above the flow connections will, of course, automatically require a minimum static head higher than shown.
5. The position of the open vent/safety pipe above the expansion cistern water level is given as a guide only. The final position will depend upon particular characteristics of the system. Pumping over of water into the expansion cistern should be avoided.
6. Both open vent/safety pipe and cold feed/expansion pipes must be of adequate diameter to suit the output of the boiler (see table below).

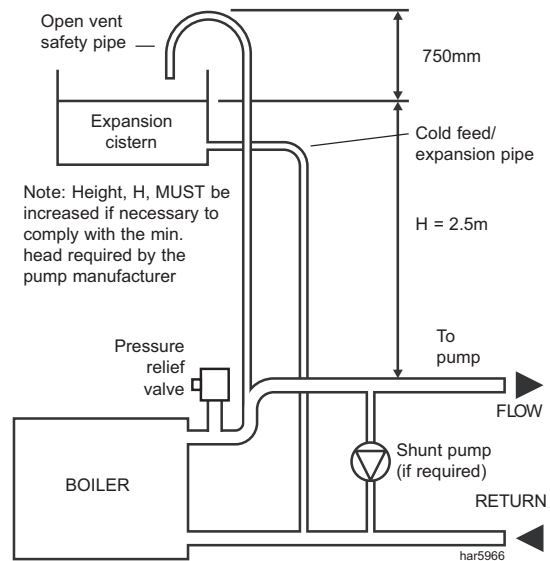

This diagram does not show safety valves & water flow switches etc necessary for safe operation

Boiler Output kW	Open Vent (mm)	Cold Feed (mm)
301 to 600	50	38
600 and above	50	50

## 7 SEALED (PRESSURISED) SYSTEMS

### Working pressure 6 bar maximum.

Particular reference should be made to BS. 6644: Section 2; Subsection 11 and Guidance note PM5 "Automatically controlled steam and hot water boilers" published by the Health and Safety Executive.

The information and guidance given below is not intended to override any requirements of either of the above publications or the requirements of the local authority, gas or water undertakings.

In general commercial closed pressurised systems are provided with either manual or automatic water make up.

In both instances it will be necessary to fit automatic controls intended to protect the boiler, circulating system and ancillary equipment by shutting down the boiler plant if a potentially hazardous situation should arise.

Examples of such situations are low water level and operating pressure or excessive pressure within the system.

Depending on circumstances, controls will need to be either manual or automatic reset. In the event of a shutdown both visual and audible alarms may be necessary.

Expansion vessels used must comply with BS. 4814 and must be sized on the basis of the total system volume and initial charge pressure.

Initial minimum charge pressure should not be less than 0.5 bar (7.2psi) and must take account of the static head and specification of the pressurising equipment. The maximum water temperatures permissible at the point of minimum pressure in the system are specified in Guidance Note PM5.

When make up water is not provided automatically it will be necessary to fit controls which shut down the plant in the event of the maximum system pressure approaching to within 0.35bar (5psi) of the safety valve setting.

Other British Standards applicable to commercial sealed systems are:

BS. 6880: Part 2

BS. 1212

BS. 6281: Part 1

BS. 6282: Part 1

BS. 6283: Part 4

## 8 SYSTEM DESIGN

### Minimum Water Flow

#### Design Flow Rates

The following table gives the flow rate required for each boiler based on a design temperature difference of 11°C (20°F) at the maximum rated output. For hydraulic resistance see Performance Data table (page 2).

#### Minimum Flow Rates

It may be necessary to fit a shunt pump to ensure minimum flow rates.

Boiler Size	GTS 8	GTS 9	GTS 10	GTS 11	GTS 12	GTS 13	GTS 14
Normal water flow rate l/s	8.47	9.77	11.73	13.03	14.55	15.63	16.94
temperature difference 11°C (20°F) g.p.m.	111.77	128.96	154.75	171.95	192.01	206.34	223.53
Minimum water flow rate l/s	2.66	3.07	3.69	4.09	4.57	4.91	5.32
temperature difference 35°C (63°F) g.p.m.	35.13	40.53	48.64	54.04	60.35	64.85	70.25

### System Design

Recommendations relating to water system design are contained in BS. 5410: Part 2 and BS. 6880.

System design must allow for adequate internal circulation within the boiler and sufficient heat release from the boiler body during and immediately after burner firing. Heating and/or hot water controls should be interlocked electrically with the burner, to prevent firing when the system does not demand heat.

Depending on system design it may be necessary to interrupt electrical supply to the burner before any mixing valves are completely closed to the boiler flow. This will dissipate residual heat. Also a pump overrun of at least 5 minutes is required on plant shutdown to avoid interference trip out of the overheat thermostat. If system return temperature remains below 30°C for most of the heating period some protection from condensation is required.

Please contact **Ideal Stelrad Group** for further information.

### Example of Installation

The example below does not cover all the possible cases of use. It is only aimed at drawing attention to the basic rules which must be complied with. In all events, comply with applicable codes of practice and national or local regulations.

Example shows a sealed system with domestic hot water production via independent calorifiers.

#### Typical Sealed System Example

A shunt pump sized on the minimum flow rate required MUST be fitted. Provided adequate heat dissipation can be achieved at all times the shunt and DHW primary pumps only may run on during the overrun period allowing the heating pump to be switched off. This example assumes the DHW primary pump flow rate required is less than that required for the shunt pump.

9 SYSTEM DESIGN CONTINUED

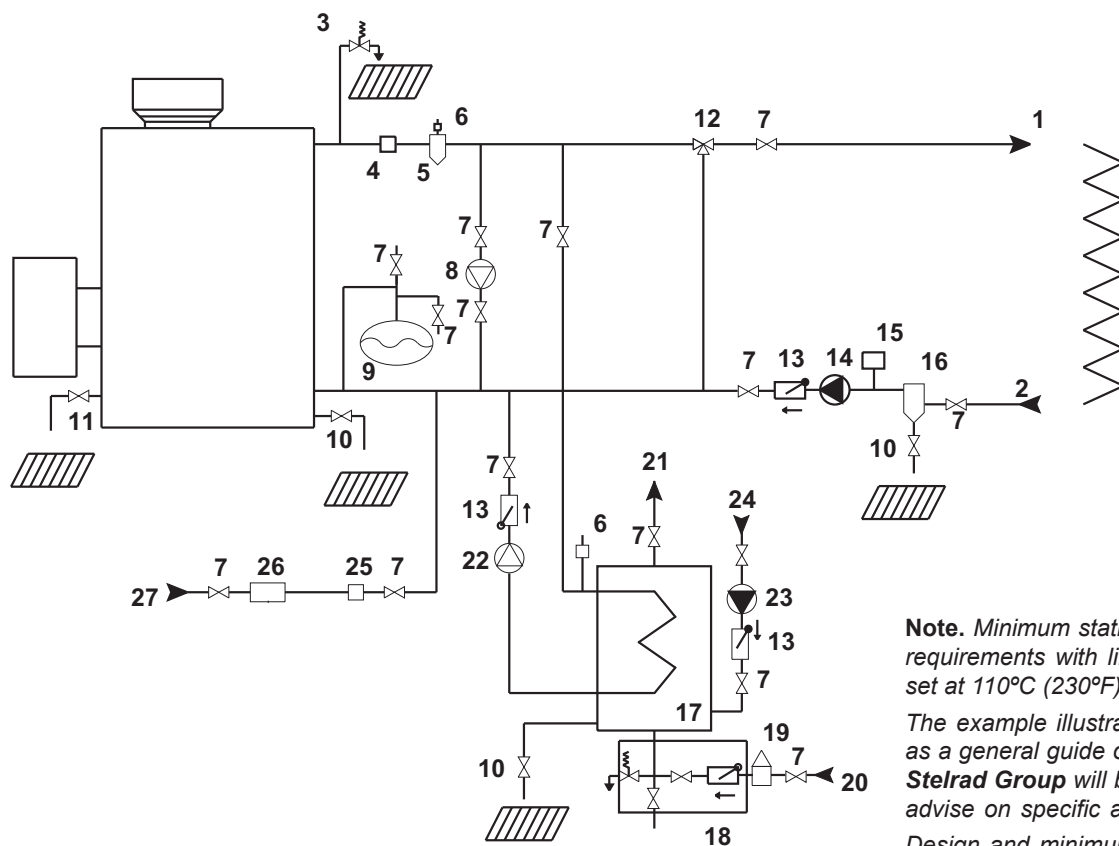

**Note.** Minimum static head requirements with limit thermostat set at 110°C (230°F) is 2.5m.

The example illustrated is intended as a general guide only. **Ideal Stelrad Group** will be pleased to advise on specific applications. Design and minimum flow rate tables are shown Frame 8.

LEGEND

- |  |  |
|--|--|
| <ul style="list-style-type: none"> <li>1. Heating flow</li> <li>2. Heating return</li> <li>3. 3bar safety valve and pressure gauge</li> <li>4. Flow switch (if necessary)</li> <li>5. Air separator</li> <li>6. Automatic venting valve</li> <li>7. Valve</li> <li>8. Shunt pump (required for all models)</li> <li>9. Expansion tank</li> <li>10. Draining valve</li> <li>11. Sludge valve</li> <li>12. Mixing valve</li> <li>13. Non return valve</li> <li>14. Heating pump</li> <li>15. Low-water safety pressure-sensitive switch</li> </ul> | <ul style="list-style-type: none"> <li>16. Sludge decanting pot (particularly recommended for older heating systems)</li> <li>17. Independent calorifier</li> <li>18. Sealed safety unit calibrated to 7bar with indicator type discharger</li> <li>19. Pressure reducer (if mains press &gt;5.5bar)</li> <li>20. Domestic cold water inlet</li> <li>21. Domestic hot water outlet</li> <li>22. DHW pump</li> <li>23. DHW circulation pump (optional)</li> <li>24. DHW circulation loop return</li> <li>25. Water meter (if any)</li> <li>26. Water treatment for hard water</li> <li>27. Heating circuit filling (with disconnecter if required under applicable regulations).</li> </ul> |
|--|--|

# INSTALLATION

## 10 FLUING

According to the output, the difference between the temperature of the flue gas and the ambient temperature can be as low as 160°C. The installer will have to respect all of the usual precautions (dilution - piping - T for removal of condensation) in order to prevent deterioration of the chimney. The use of a draught stabiliser is also recommended.

### FLUE SIZE

Refer to applicable regulations while determining the size and height of the flue. Please note that Viceroy GTS boilers have pressurised and sealed combustion chambers and that the pressure at the outlet must not exceed 0 mbar.

Detailed recommendations relating to the design of flues for GAS fired appliances are quoted in BS. 6644 and IGE/UP/10, whilst BS. 5410 Pt. 1 similarly applies to OIL fired boilers.

The table below contains the minimum dimensions of the flue required for each boiler model in order to ensure sufficient draught at the outlet.

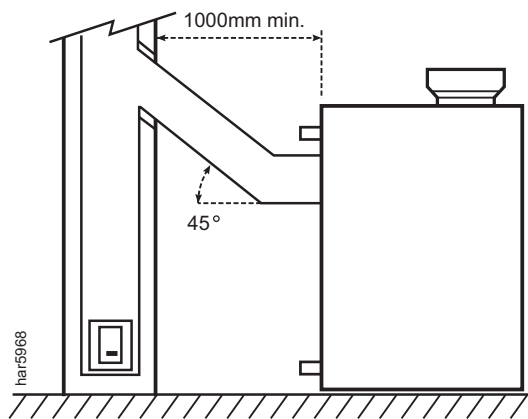

However, care must be taken to comply with any applicable national or local regulations.

Boiler	Heat Output kW	Required Draught mbar	Mass Flow of Flue Gases kg/s		Flue Gas Temperature (1) (2) °C	Chimney: Minimum Recommended Diameter Ø min mm
			Fuel Oil 13% CO <sub>2</sub>	Natural Gas 9.5% CO <sub>2</sub>		
GTS 8	390	0	0.184	0.193	220	250
GTS 9	450	0	0.212	0.223	220	250
GTS 10	540	0	0.255	0.267	220	250
GTS 11	600	0	0.283	0.297	220	300
GTS 12	670	0	0.316	0.332	220	300
GTS 13	720	0	0.340	0.357	220	300
GTS 14	780	0	0.368	0.386	220	300

(1) : at boiler maximum input.

(2) : Boiler flow temperature: 80°C (ambient temperature : 20°C).

## 11 DIMENSIONAL INFORMATION REQUIRED FOR THE FLUE CONNECTION

### Connection

The connection must be made in a competent manner with airtight pipe in a material that is resistant to hot gases from the combustion and possible acid condensation. This pipe must be as short as possible, be removable and without any sudden change in its section.

The diameter must always be at least equal to that of the boiler outlet.

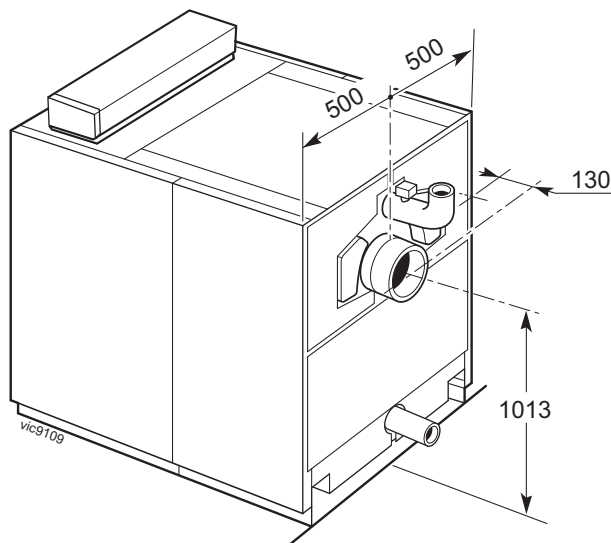

# INSTALLATION

## 12 BURNER CONNECTION

### Gas Supply

The gas supply MUST be sized in accordance with British Gas recommendations.

The Local Gas Authority should be contacted, at a stage prior to actual installation, for any advice or information required.

### Oil Storage Tank

The oil storage tank, oil supply pipe and connections to the burner unit MUST comply with the requirements of BS. 799.

The installation should conform to the recognised standards of good practice in the trade and comply with the relevant Codes of Practice, building Regulations and Local Authority, Fire and Insurance requirements.

**IMPORTANT.** The burner head deflector must be in line with the door insulation as shown opposite.

If there is space between the burner blast tube and door insulation after mounting the burner, a suitable insulation material must be used to pack the space.

Connection, adjustment, start-up and maintenance.  
(Refer to the instructions delivered with the burner)

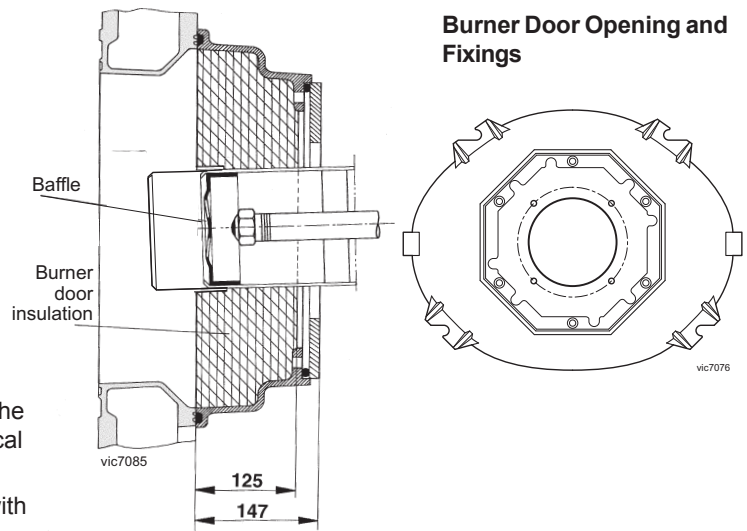

## 13 ASSEMBLY

### Packaging:

The tables below show the numbers of the packages which make up the boiler. The packages are listed in the order in which they are opened for assembly.

### Tools required:

(not supplied)

- 12mm allen key
- Cross head screwdriver
- 13, 19 and 24mm spanners
- Knife
- Hammer
- 22mm box spanner
- JDTE assembly tool
- Putty gun

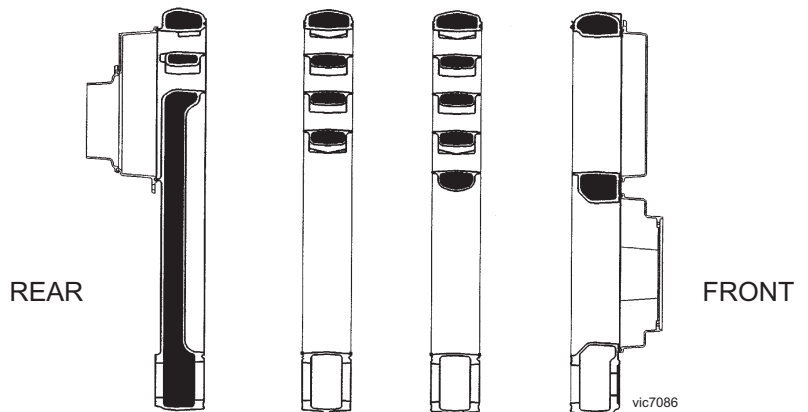

Boiler	GTS 8	GTS 9	GTS 10	GTS 11	GTS12	GTS 13	GTS 14
Base frame (dimensions according to model)	1	1	1	1	1	1	1
Front section	1	1	1	1	1	1	1
Normal intermediate section	5	6	7	8	9	10	11
Special intermediate section	1	1	1	1	1	1	1
Rear section	1	1	1	1	1	1	1
Common accessories	IE20	IE 20	IE20	IE20	IE20	IE20	IE20
Boiler accessories in bulk (contents according to model)	1	1	1	1	1	1	1
Baffles	IE30	IE31	IE31	IE32	IE32	IE33	IE33
Base insulation	IE51	IE53	IE53	IE55	IE55	IE57	IE57
Casing: common parts	IE70	IE70	IE70	IE70	IE70	IE70	IE70
Casing: varying parts	MP3	MP4 MP5	MP2 MP4	MP3 MP4	MP4 MP5	MP2 MP4	MP3 MP4
Wiring ducts	IE41	IE42	IE43	IE44	IE45	IE46	IE47
Control panel	ID46	ID46	ID46	ID46	ID46	ID46	ID46
Burner door	1	1	1	1	1	1	1

The assembly of any optional devices purchased with the boiler is described in the instructions supplied with the relevant device. The list of available optional devices is shown on page 3.

# INSTALLATION

## 14 PREPARING THE BASE FRAME AND FITTING THE BASE INSULATION

1. Remove the nuts and bolts holding the base frame components in their packed form.
2. Locate the crossmembers under the longitudinal members.
3. Secure the cross member with the nuts, bolts and two washers.
4. Fit the 2 rear attachment brackets (in the body accessories pack) and attach them onto the framework using two M12 x 40 bolts, four washers and two nuts.

Caution: use the corresponding holes according to the indications on the framework.

5. Put the lower insulation in place (fabric to top) packs IE 51 to IE 57. Adapt length if necessary or fold the lower insulation after the casing has been completely assembled.

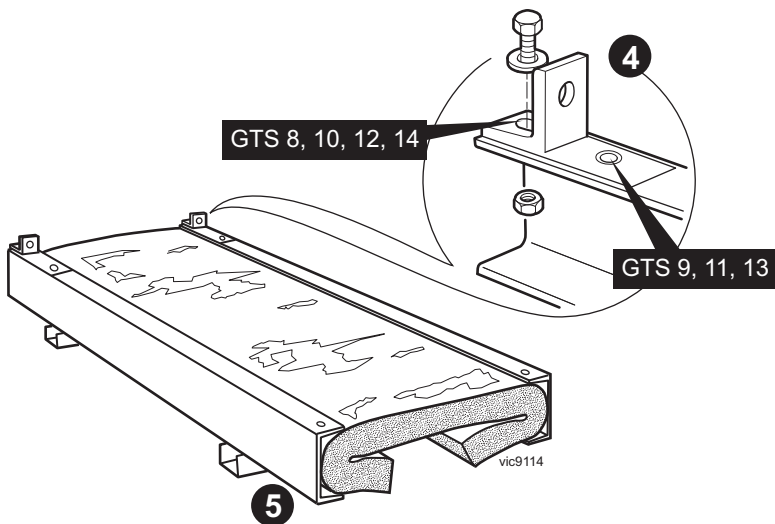
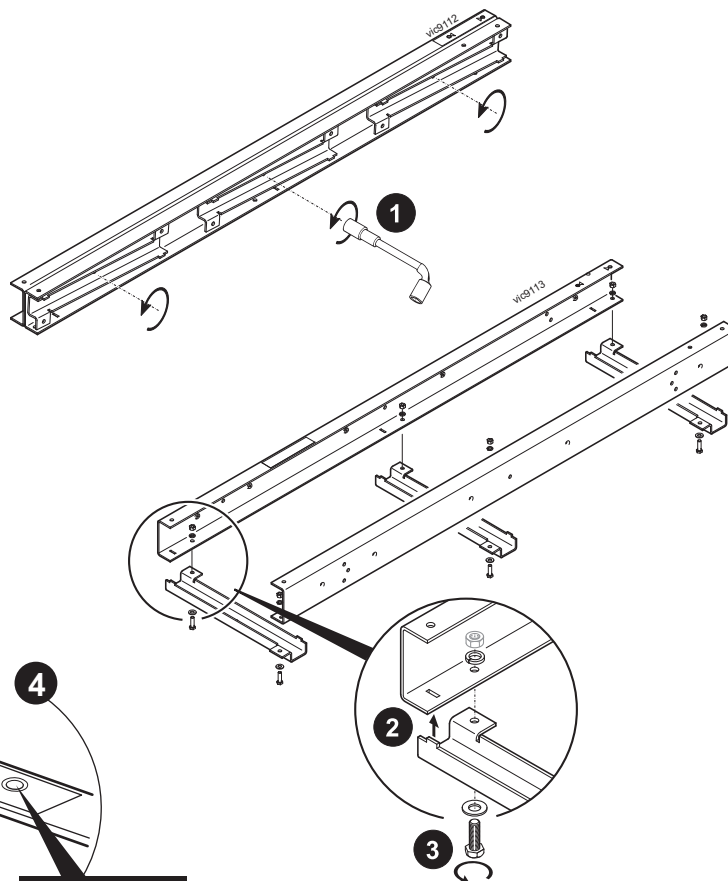

## 15 POSITIONING THE REAR SECTION

1. Determine the required location of the framework depending on the direction in which the burner door will be opened and the length of the burner.
2. Place the rear section on the framework and support it with a wooden block. Attach it at the brackets using two M12 x 40 bolts, four washers and two nuts.
3. Carefully inject a drop of silicone mastic approximately every 100mm and put the thermocord in place (body accessories pack) in the sealing groove and cut to the correct length.

### Note.

Do not pull on the cord when it is being put in, to avoid stretching and to preserve its thickness.

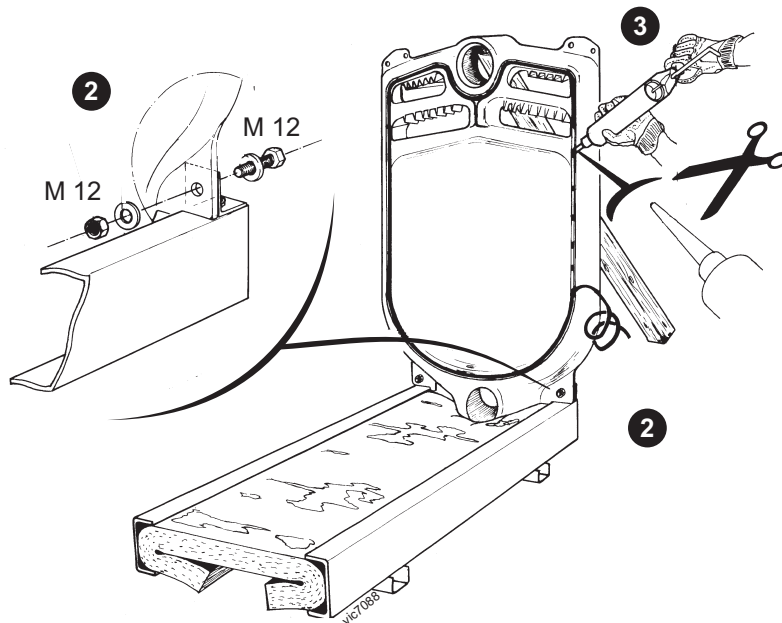

# INSTALLATION

## 16 PREPARING THE REAR SECTION

1. Clean the nipple ports and nipples with cleaning fluid.
2. Coat them with the lubricant supplied with the sections.
3. Drive in the two nipples gently.

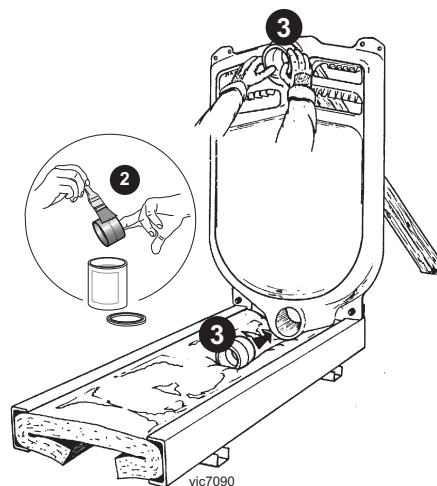
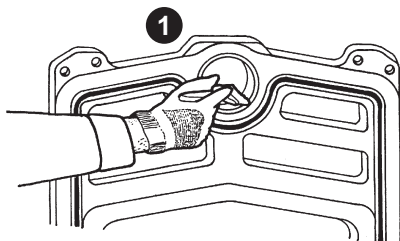

## 17 ASSEMBLING THE SPECIAL INTERMEDIATE SECTION

**Note.**

- a. The section can be identified as having only three flueways.
- b. This section must be positioned next to the rear section to ensure correct flue gas path.

1. Place the special intermediate section onto the base frame. The arrow marker points to the rear to denote the correct way to fit the section.
2. Fit the connections of the special intermediate section onto the nipples in the rear section.
3. Ensure that the thermocord fits evenly between the sections in the correct manner to make a good seal.
4. Hammer in with the help of a small wooden block.
5. For safety reasons, insert an upper assembly rod (body accessories pack) into the holes in the sections.
6. Insert the assembly tool through the nipples and tighten.

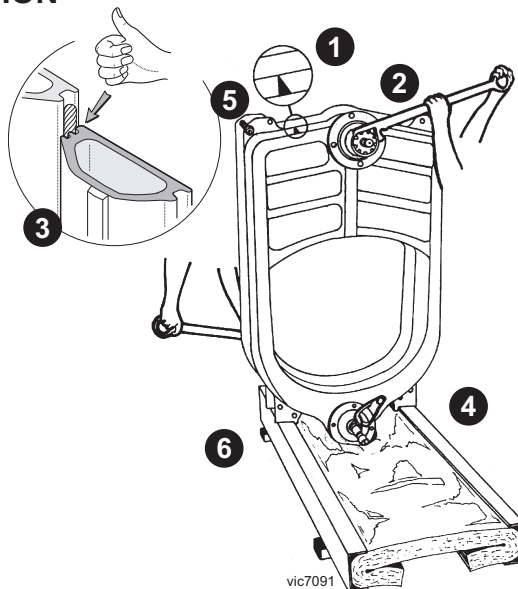

## 18 ASSEMBLING THE INTERMEDIATE AND FRONT SECTIONS

1. Proceed likewise for other intermediate and front sections.
2. Leave the assembly tool in place after fitting the front section.

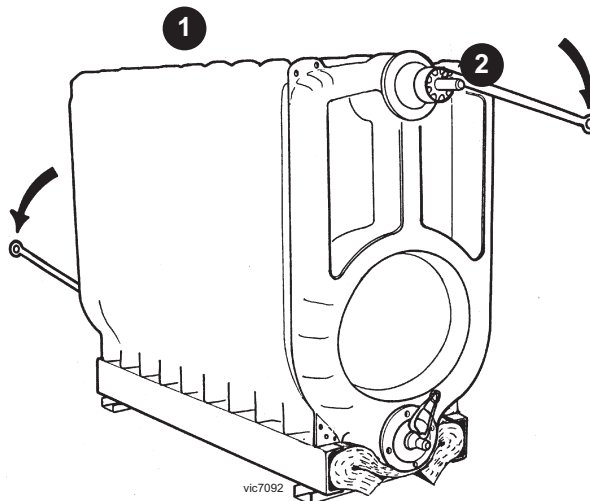

# INSTALLATION

## 19 FITTING THE ASSEMBLY RODS AND UPPER CASING SUPPORTS

1. Fit the upper assembly rods (body accessories pack) in the order given in the appropriate diagram.
2. Place the expansion spring and its washer on each rod towards the rear. Stop tightening the nuts when the free space between the threads is about 2 mm.
3. Fix the upper casing supports (pack MP4) and the upper crosspieces (packs IE70, MP2, MP3, MP5) with the assembly rods. (body accessories pack) as shown in details 1, 2, 3 and 4.
4. Fit the lower assembly rods in the order given in the diagram in the same manner.
5. Remove the assembly tool.

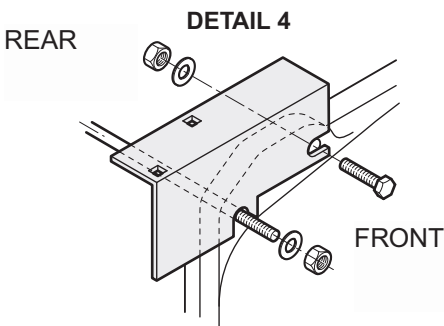
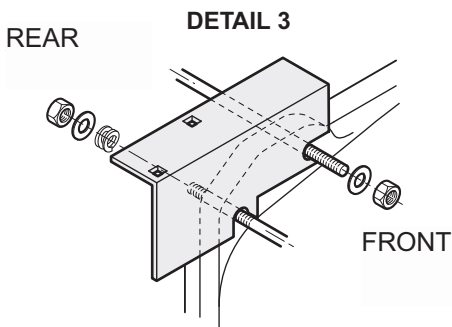
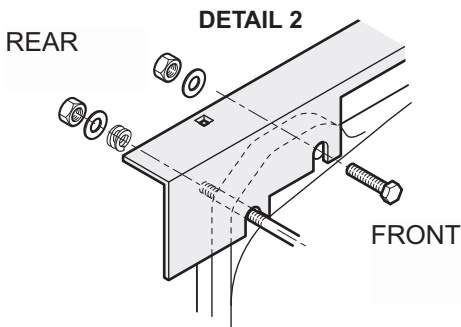
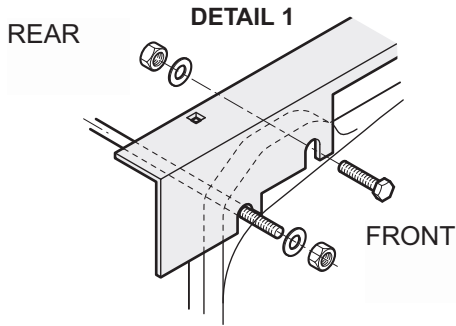

vic9115

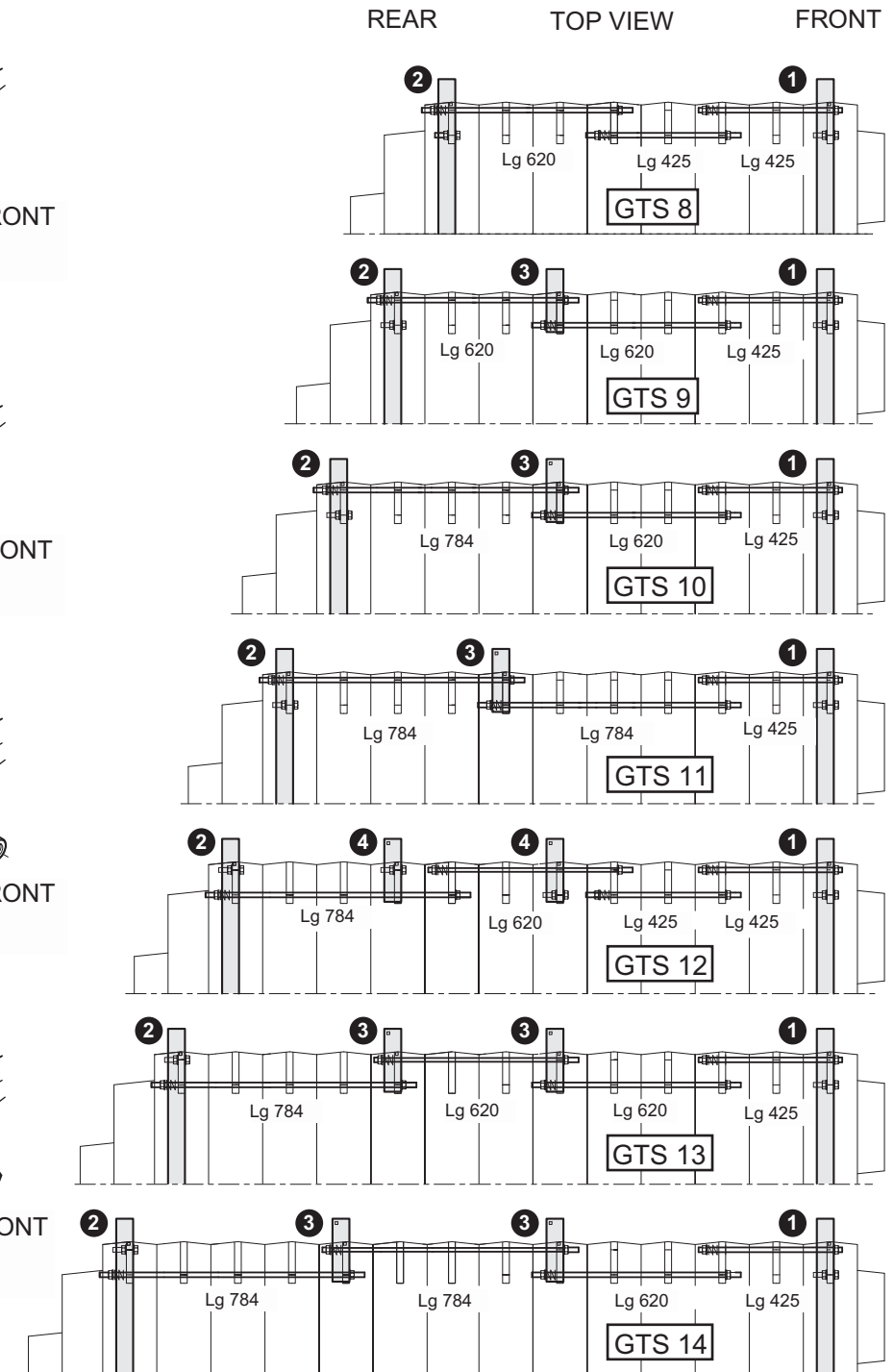

## 20 HYDRAULIC TEST

After assembling the boiler body, the installer must carry out a water tightness test at a hydraulic pressure of 1.5 times the design pressure for a period of 30 minutes. The test must be done at room temperature.

1. Seal off the flow and return connections with blank flanges
2. Fit a suitable supply line with valves and union connection.
3. Fit a suitable valve to vent the boiler. (Temporary only.)

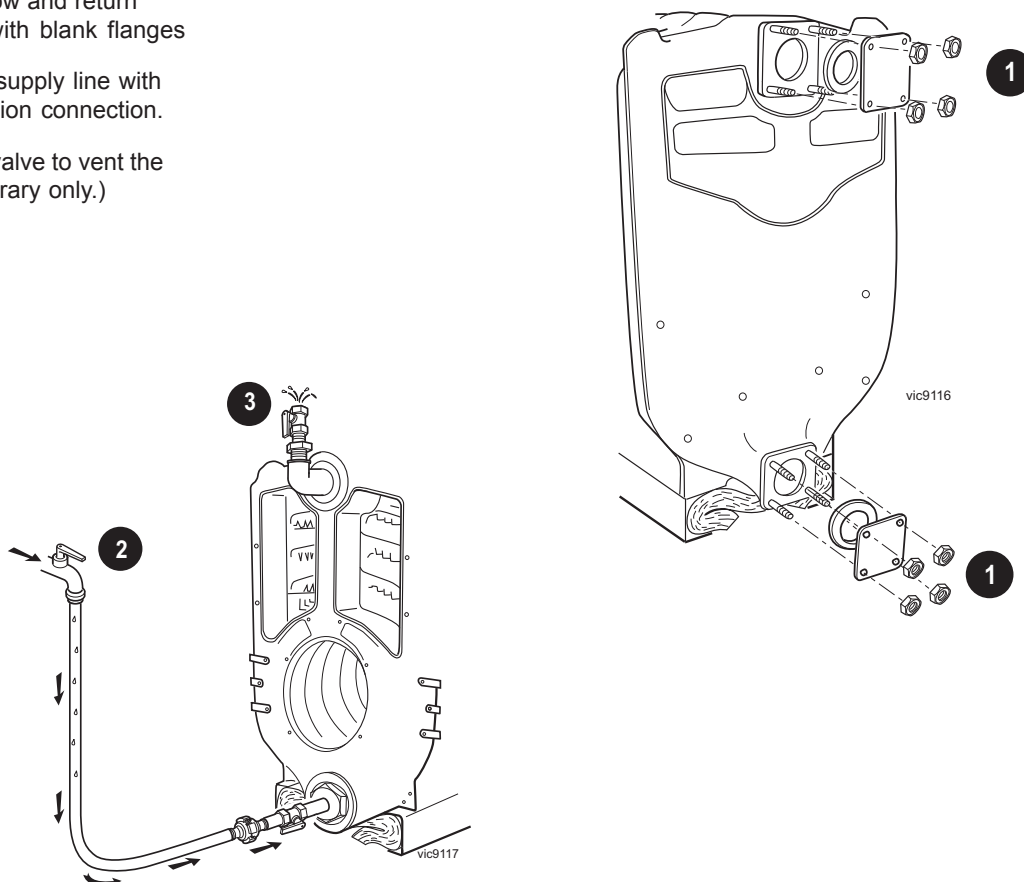

4. Fill the boiler then shut off the supply water.
5. Shut off the inlet valve.
6. Close the vent valve.
7. Disconnect the supply water.
8. Connect the pressure system water.
9. Open the fill valve.
10. Pressurise the boiler. Maintain pressure for **30 minutes**.  
Any drop in pressure indicates a leakage in the boiler body.
11. After successfully conducting the test, release the pressure and drain.
12. Remove all parts used for the test.

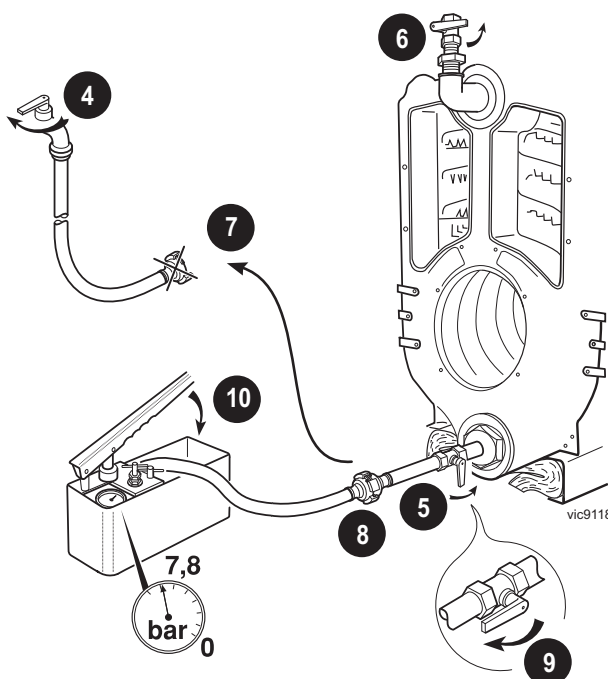

## INSTALLATION

### 21 FITTING THE SMOKEHOOD

1. Fix the flue outlet spigot (body accessories pack) to the smokehood using four M12x40 bolts, nuts and washers.
2. Screw in the two threaded rods (body accessory pack) M12x175 for the flue outlet.

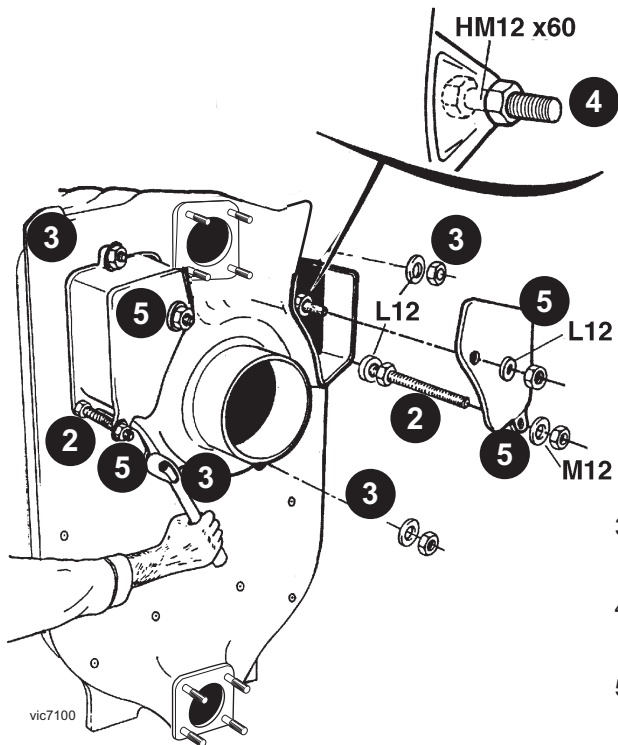
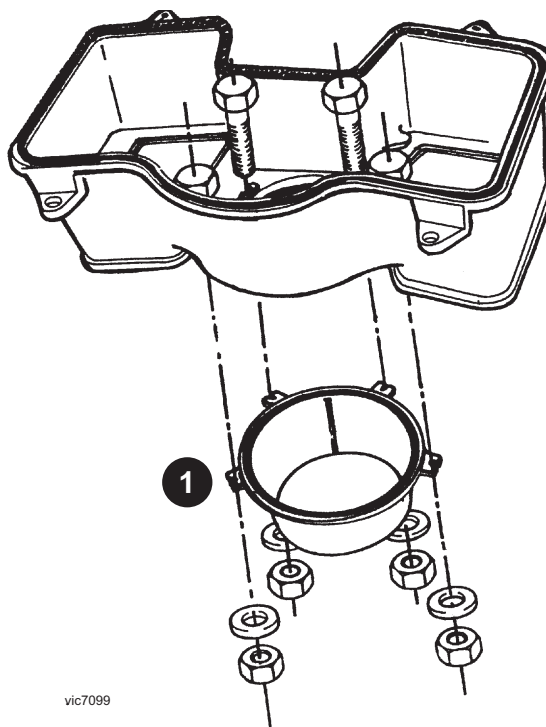

3. Secure the flue outlet onto the rear section with six M12 nuts and washers.
4. Fit two M12 bolts and nuts on the smokehood for the cleaning doors (see detail).
5. Secure the cleaning doors using four M12 and two washers (L12) and two washers (M12).

### 22 ASSEMBLING THE FLOW AND RETURN TAIL PIPES

1. Fit eight M16 studs into the flow and return flange faces on the rear section.
2. Fix the flow and return flanged tail pipes using four M16 nuts for each flange with a gasket as shown.

**Note.**

**A.** The flow tail pipe outlet must face upwards to accommodate the flow switch.

**B.** The return flange for models GTS11-14 incorporates a distributor tube and must be fitted the correct way as shown (market INJ).

3. Screw the flow switch into the flow tail pipe using suitable compound ensuring the arrow on the casing corresponds to the direction of water flow.

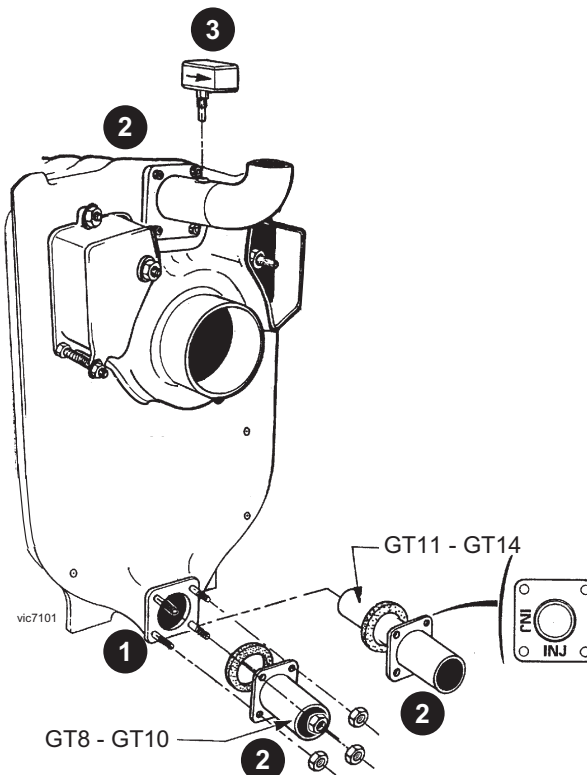

## INSTALLATION

### 23 FITTING THE THERMOSTAT SENSOR POCKET, PLUGGING THE UNUSED TAPPING AND PREPARATION FOR FITTING THE FLUE CLEANOUT AND BURNER DOORS

1. Screw in the lower plug and upper plug with the sensor tube.
2. Screw in and tighten the eight M12x50 studs for the cleaning doors.
3. Screw in the two M12x85 studs for the hinges of the flue cleanout doors (short end into the section).
4. Fit the hinges for the flue cleanout doors (pack IE 20) using two M12x25 bolts, serrated washers (DE12) and nuts.
5. Fit the combustion chamber door hinge (body accessories pack) on the left or the right according to the direction in which the door will be opened, and fix using three M12x30 bolts and washers.
6. Fix the burner door guide bracket (body accessories pack) using two M12x25 bolts and washers (L12).

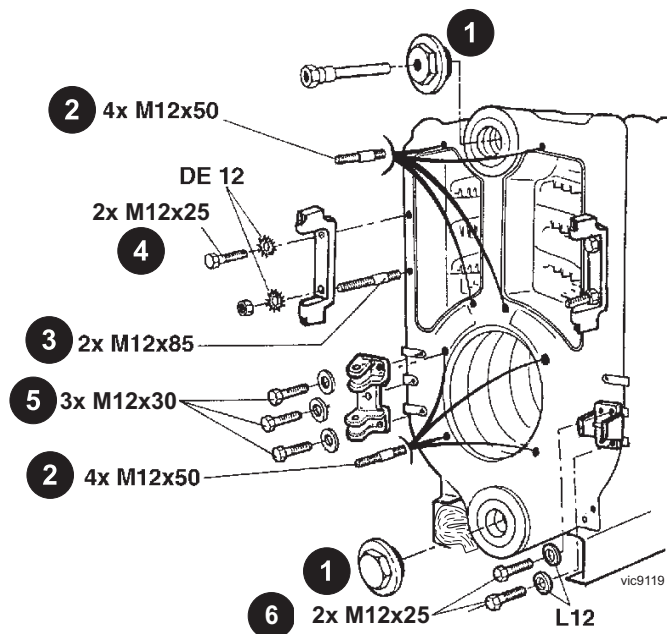

### 24 ASSEMBLING THE BURNER AND FLUE CLEANOUT DOORS

1. Position the burner door in place and secure with four M12 nuts and washers.
2. Locate the hinge and secure with the hinge pin.

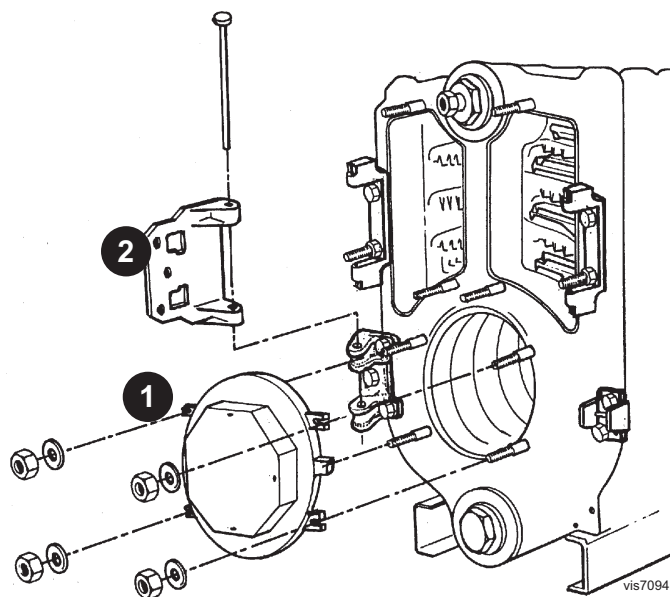
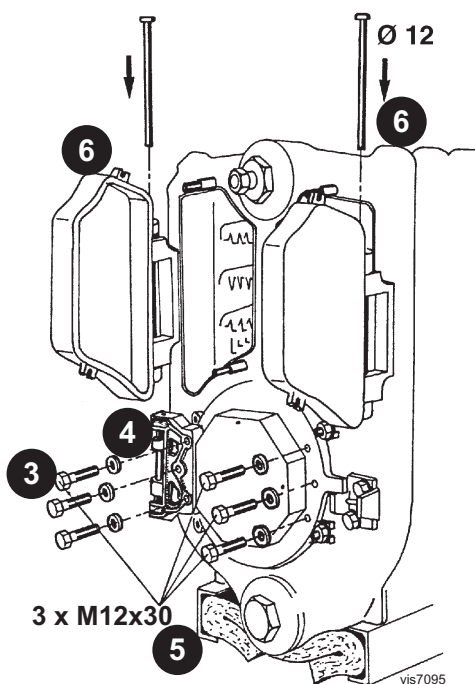

3. Remove the three M12x30 bolts and washers on the side the burner door is to be hinged.
4. Swing the hinge into place and secure to the burner door.
5. Leave the three M12x30 bolts and washers in the other side of the burner door.
6. Fit the left and right hand flue cleanout doors in place with their pins (pack IE 20)

**Note.**

*Do not close and secure the doors at this time.*

# INSTALLATION

## 25 POSITIONING THE FLUE BAFFLES

1. Install the upper (1), middle (2) and lower (3) + (4) baffles, respecting the sequence of assembly given in the chart.
2. Important: Interlock the baffles one into another before placing them in the flue way.
3. Close the cleaning doors and secure with three M12 locknuts and washers.

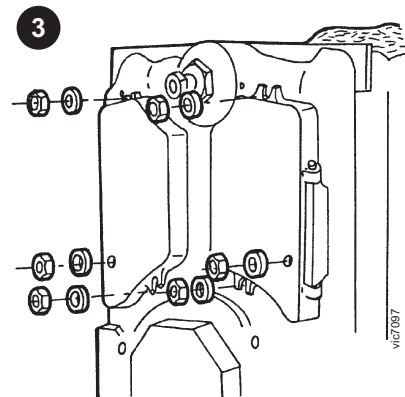
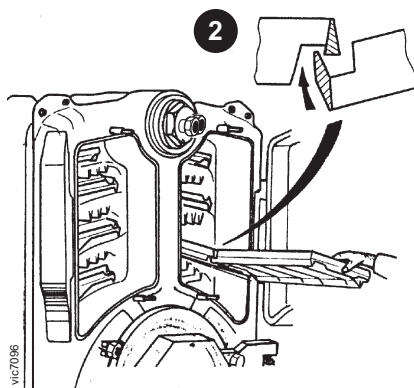
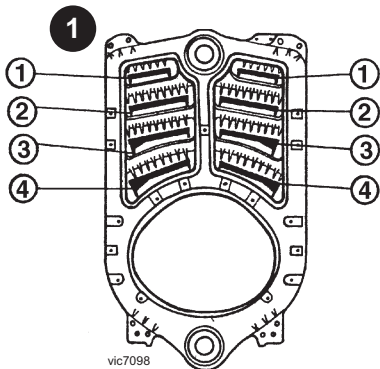

Baffles (by flue way)	Viceroy GTS 8 pack IE 30	Viceroy GTS 9-10 pack IE 31	Viceroy GTS 11-12 pack IE 32	Viceroy GTS 13-14 pack IE 33
Upper ①	8229-0010 then 8229-0022	2x8229-0010	2x8229-0010 then 1x8229-0022	3x8229-0010
Middle ②	8229-0011 then 8229-0023	2x8229-0011	2x8229-0011 then 1x8229-0023	3x8229-0011
Lower ③ and ④	8229-0012 then 8229-0024	2x8229-0012	2x8229-0012 then 1x8229-0024	3x8229-0012

**Note.** The part number of the baffles is marked on the casting.

# INSTALLATION

## 26 FITTING THE CASING SUPPORTS

1. Fix the lower casing supports to the framework using one M8x25 bolt and lock washer for each support.

**Note.**

The quantity varies according to the boiler length.

**Note.**

For pre-assembled boilers loosen the base frame securing bolts.

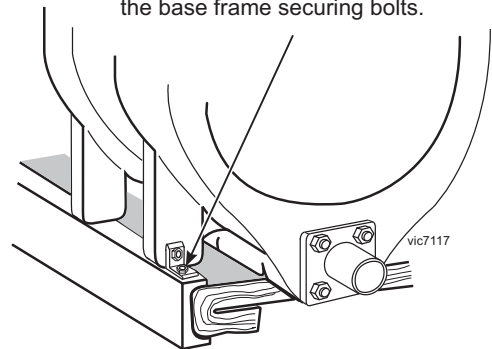
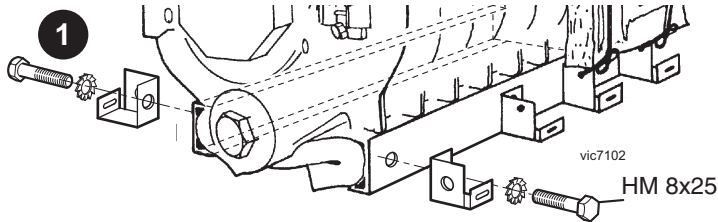

## 27 INSTALLING THE INSULATING MATERIAL

1. Lay the insulation panels over the boiler.
2. Secure the insulation in place by tying each strap to the lower casing support at each side of the boiler.

**Note.**

The table below indicates the quantity of insulation panels supplied for each boiler and the appropriate position according to their width.

3. Fit the rear insulation.

**Note.**

This will be held in place by the rear panels when fitted later (Frame 34).

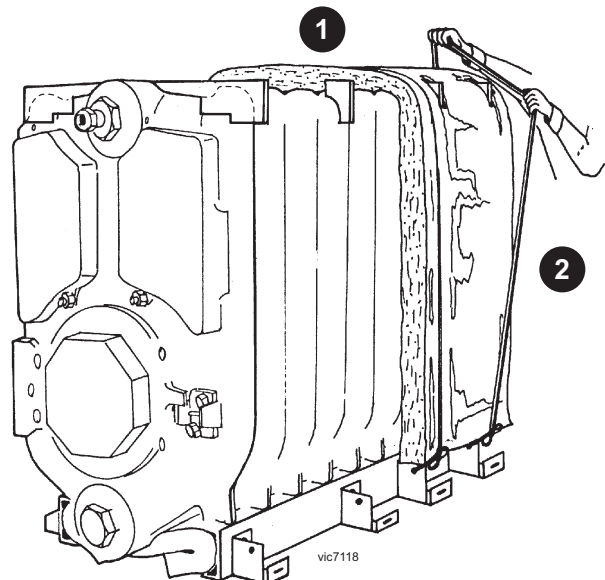

Boiler	Body insulation width				
	Front	←	→	Rear	
	500	500	600	800	900
GTS 8	1				1
GTS 9	1	1	1		
GTS 10	1	1		1	
GTS 11	1	1			1
GTS 12	1	2	1		
GTS 13	1	2		1	
GTS 14	1	2			1

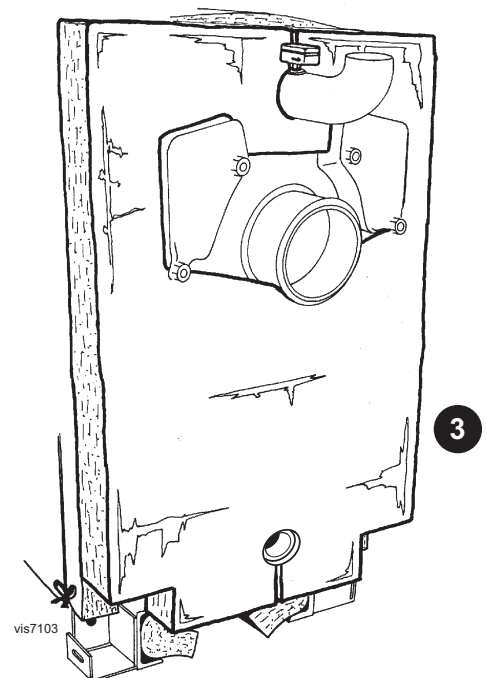

## INSTALLATION

### 28 ASSEMBLING THE WIRING DUCTS AND FRONT TOP PANEL

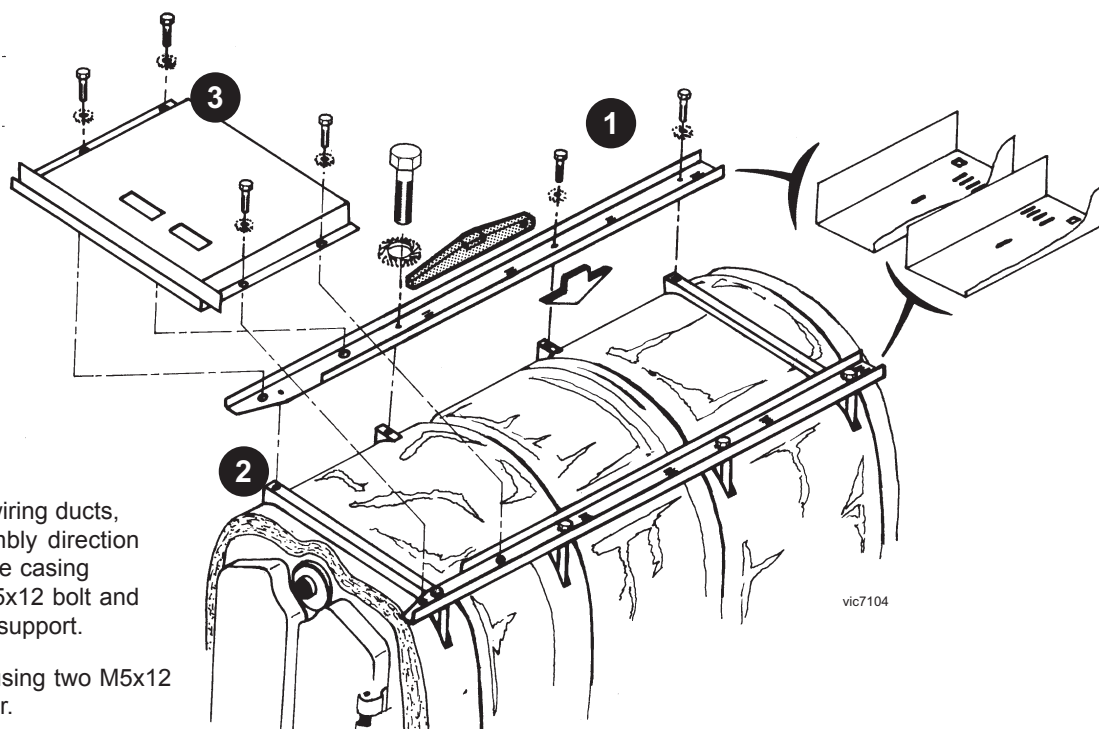

1. Fit the left and right wiring ducts, respecting the assembly direction and attach each to the casing support using one M5x12 bolt and lock washer at each support.
2. Fit the cross pieces using two M5x12 bolts and lock washer.
3. Fit the front top panel and secure to the wiring ducts using M5x12 bolts and lock washers.

### 29 INSTALLING THE MAINS AND CONTROL WIRING

1. Route the mains supply in at the rear, along one of the wiring ducts and up through the opening in the front top panel.
2. Route any remote sensor cables similarly in the other wiring duct.
3. Secure the cables with the cable ties.

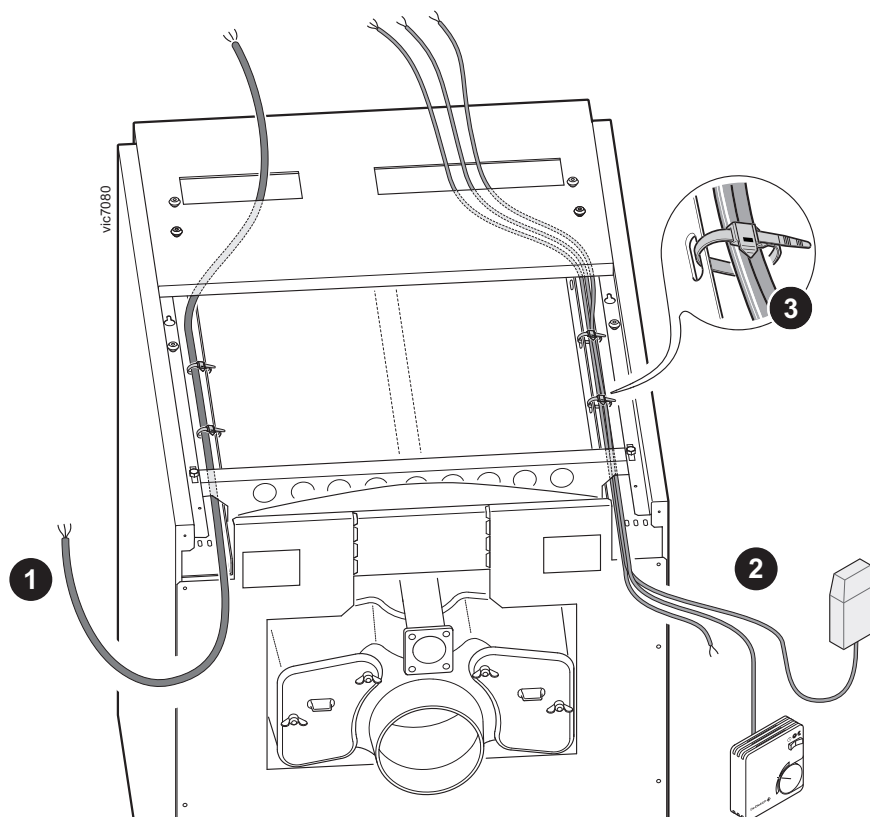

## 30 INSTALLING THE CONTROL PANEL

1. Route the sensors through the left or right hand opening in the front top panel.
2. Route the burner leads through the other opening in the front top panel.
3. Lower the control panel onto the location buttons nearer the front and slide the control panel forwards.

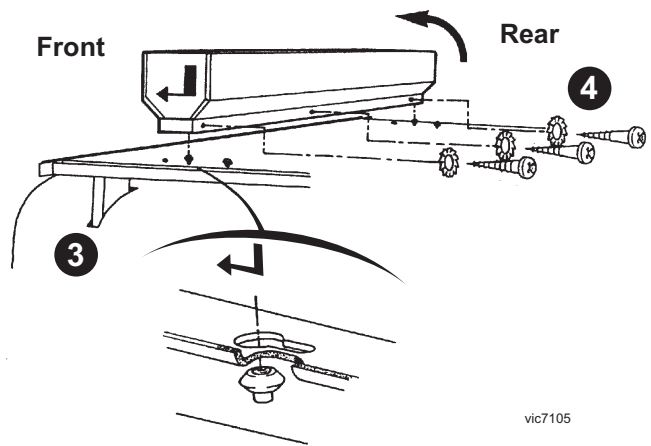
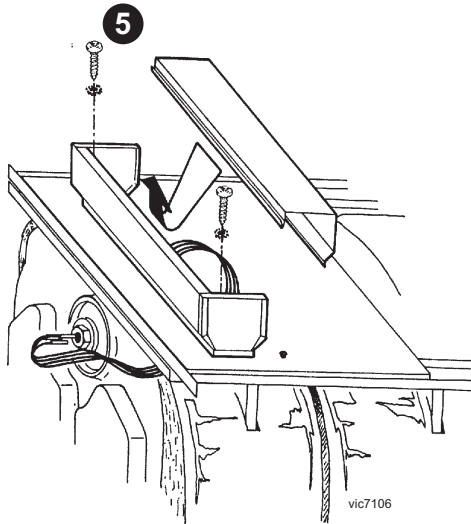

4. Remove the three screws from the rear of the control panel and remove the top/rear cover.
5. Secure the control panel to the casing top front panel with two self tapping screws and shakeproof washers provided.
6. Pull the mains cable and any other sensors into the control panel through the appropriate opening ready to make the connections.

## 31 INSTALLING THE SENSORS AND ROUTING THE BURNER CABLE

1. Route the burner cable inside the front edge return of one side of the casing side panels opposite the burner hinges. (RH side shown for clarity. See Frame 32.)

Carefully unroll and take out the various sensors from the control panel and pass them through the opening in the front top cover panels.

2. Insert the sensors into the sensor pocket.
3. Loop the sensor leads back over the sensor pocket.
4. Secure the leads with the spring clip.

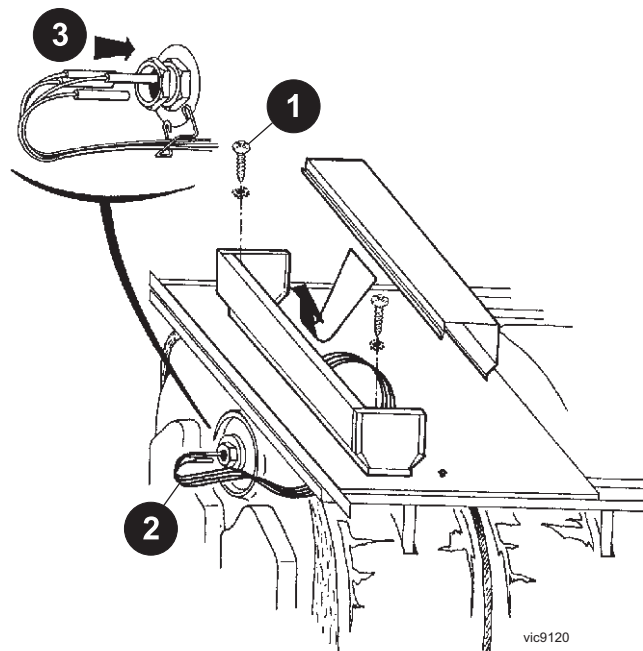

# INSTALLATION

## 32 ASSEMBLING THE CASING SIDE PANELS

1. Position the front side panels (length 520) in the lower casing supports, then hook onto the wiring ducts.
2. Fix at the sides onto the lower casing supports using M5x12 bolts and lock washers and at the front top panel using self tapping screws and lock washers.
3. Fit the remaining side panels in the order given in the table below. Position each panel in the lower casing supports then hook onto the wiring duct.

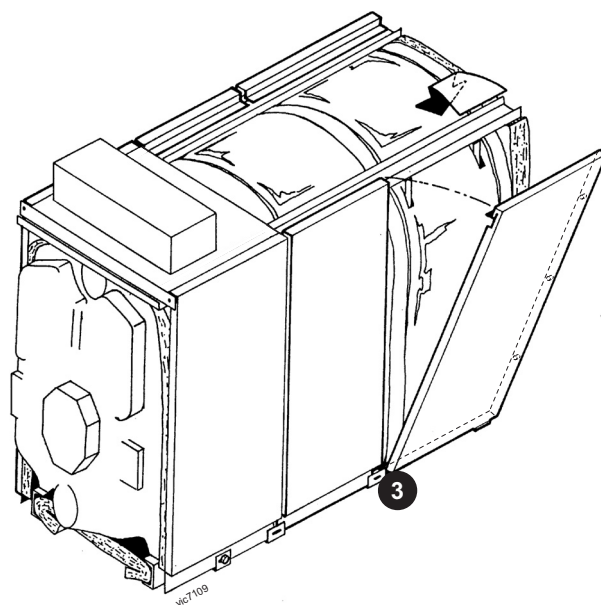
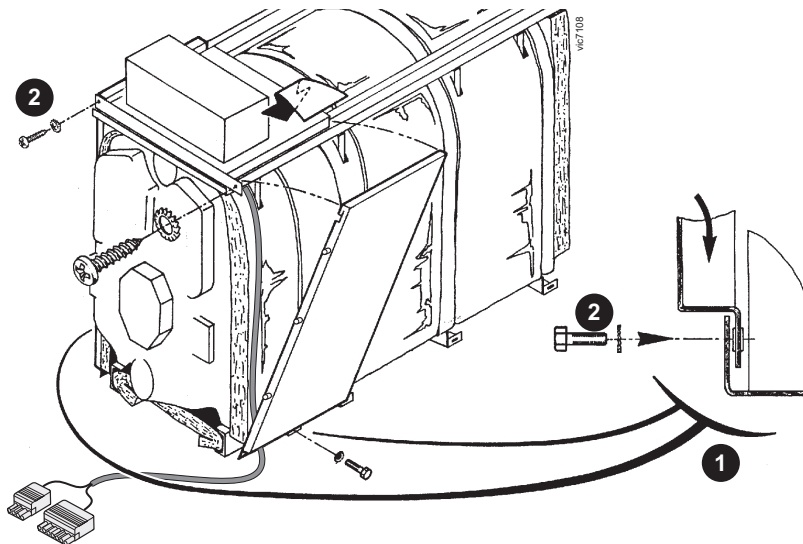

Boiler	Side panel width			
	Front ←			→ Rear
GTS 8	520(IE70)	930(MP3)		
GTS 9	520(IE70)	480(MP4)	610(MP5)	
GTS 10	520(IE70)	480(MP4)	770(MP2)	
GTS 11	520(IE70)	480(MP4)	930(MP3)	
GTS 12	520(IE70)	480(MP4)	480(MP4)	610(MP5)
GTS 13	520(IE70)	480(MP4)	480(MP4)	770(MP2)
GTS 14	520(IE70)	480(MP4)	480(MP4)	930(MP3)

## 33 ASSEMBLING THE CASING TOP PANEL

1. Fix the top covers from front to rear in the order given in the table below.
2. Fix the first intermediate top cover (length 480) onto the wiring duct using four M5x12 bolts and lock washers.
3. Fix the remaining top covers onto the wiring duct using two M5x12 bolts and lock washers.

Boiler	Front Top Panel	Intermediate Top Panel	Rear Top Panel	Pack
GTS 8	480(IE70)	480	490	MP3
GTS 9	480(IE70)	480 480	170	MP4, MP5
GTS 10	480(IE70)	480 480	330	MP2, MP4
GTS 11	480(IE70)	480 480	490	MP3, MP4
GTS 12	480(IE70)	480 480 480	170	MP5, MP4
GTS 13	480(IE70)	480 480 480	330	MP2, MP4
GTS 14	480(IE70)	480 480 480	490	MP3, MP4

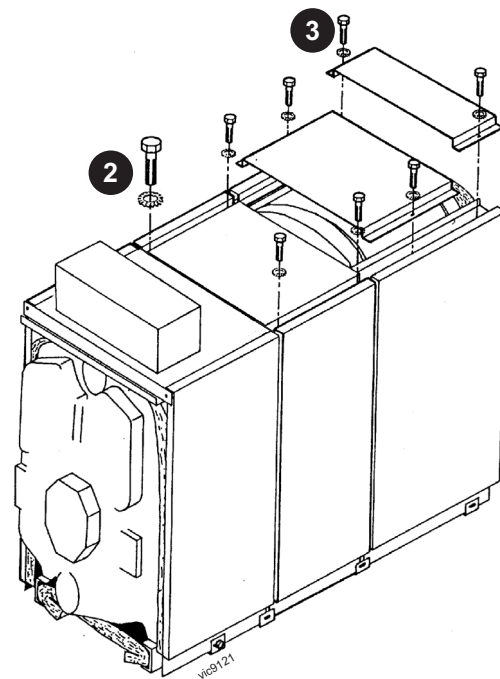

## INSTALLATION

### 34 ASSEMBLING THE REAR PANELS

1. Hook the middle rear panel onto the side panel buttons
2. Secure onto the side panels using two self tapping screws and lockwashers without tightening them.
3. Hook the left and right upper rear panels onto the side panel buttons.
4. Secure onto the middle rear panel using one self tapping screw and lock washer and onto the rear top cover using two self tapping screws and lock washers.
5. Hook the lower rear panel onto the two screws on the middle panel and tighten these screws.
6. Secure using two self tapping screws and lock washers.

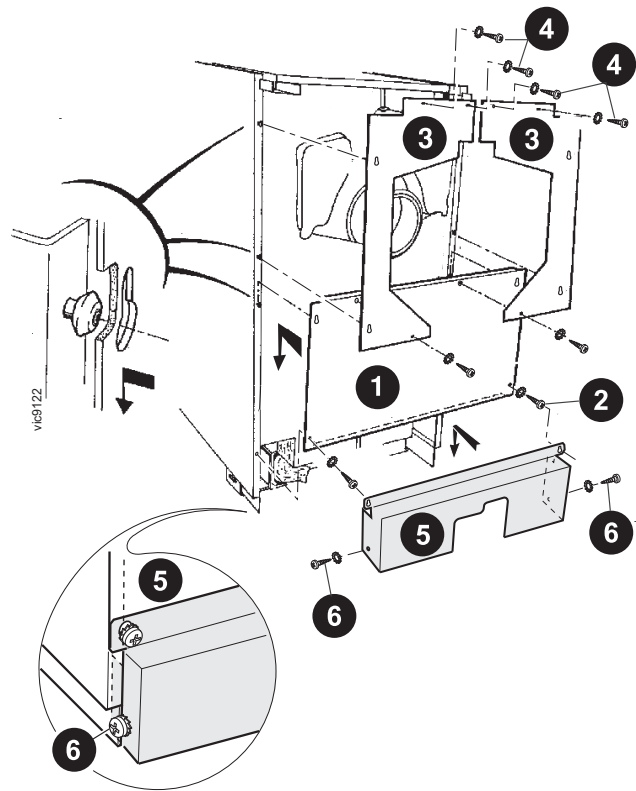

### 35 ASSEMBLING THE LOWER FRONT PANELS

1. Fit the lower front panel onto the crosspiece (two self tapping screws and lock washers.)
2. Fit the lower crosspiece assembly by securing onto the side panels using two self tapping screws and lock washers.
3. Fit the burner upper front panel onto the burner door and secure using two M12x25 bolts and washers.

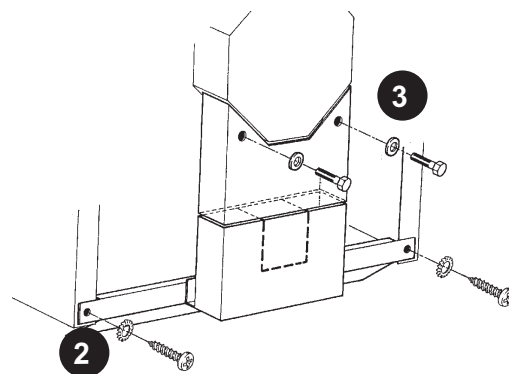
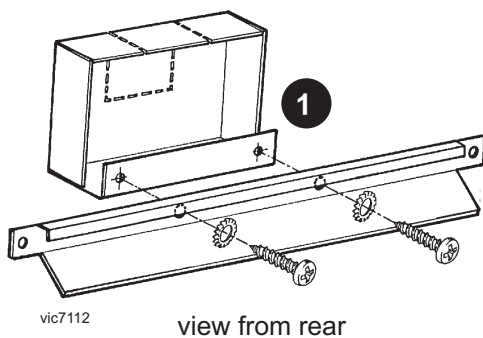

# INSTALLATION

## 36 ASSEMBLING THE FRONT PANELS

1. Hook the left and right lower front panels on the side panel buttons.
2. Hook the front casing support (two slots) into the side panel slots.

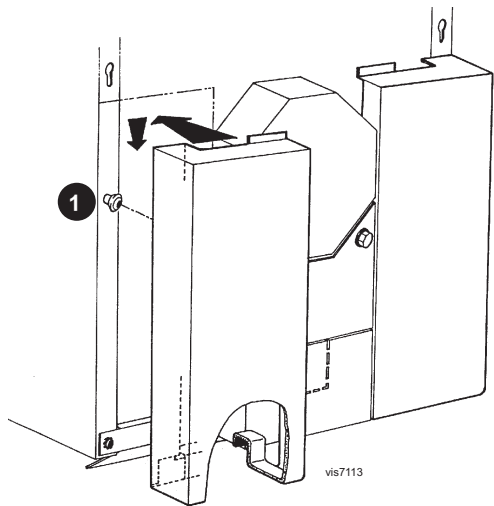

3. Position the upper front cover lower edge behind the front casing support and hook it over the front top cover.

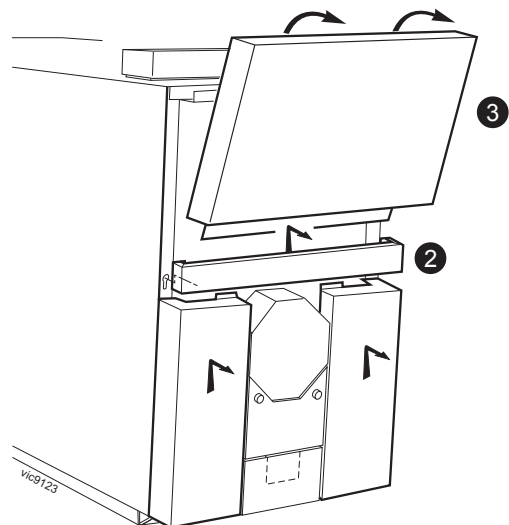

## 37 NAMEPLATE

1. Affix the identification plate (supplied in the instructions bag) on the casing (on the left or right-hand side) in an easily accessible location.

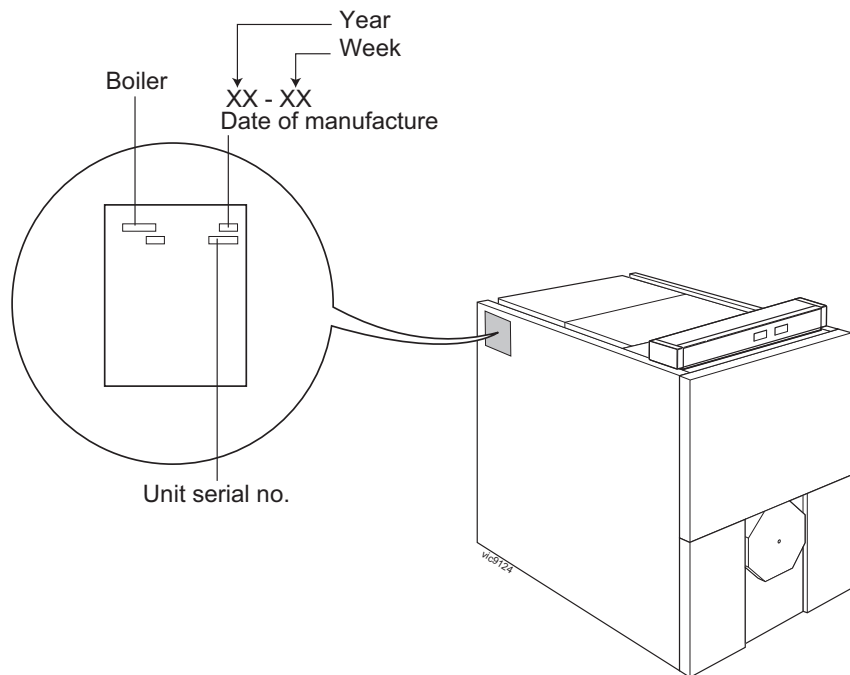

## 38 CONTROL PANEL (General)

Refer to Frame 45 for specific details of panel.  
Electrical control panel, equipped with temperature control.

### The control panel carton contains:

Control panel complete with burner connection harness.  
The control panel incorporates a boiler thermostat controller, a thermometer and a safety thermostat.

**The boiler thermostats** - one controls the maximum boiler operating temperature. The other controls the high/low operation if a two stage burner is fitted.

**The safety thermostat** (with manual reset) - if the boiler temperature rises abnormally (110°C), the safety thermostat cuts off the burner electricity power supply.

**WARNING.** In this case, you must call your installer.

## 39 ELECTRICAL CONNECTIONS

**WARNING.** The electrical connections must be made by a qualified professional. The electrical wiring has been carefully checked in the factory and the internal connections of the control panel must not be modified in any event.

The electrical connections should be made following the information shown on the electrical diagrams delivered with the unit and the directions given in the instructions.

The electrical connection must comply with standards in force. The equipment must be powered by a circuit containing a remote double-pole switch with opening  $\geq 3\text{mm}$ .

**WARNING.** The boiler must be earthed.

All connections must be made using the terminal blocks provided for this purpose at the back of the boiler control panel.

Connections cables are brought inside the boiler through cut-outs provided in the boiler back panel, which are large enough for use of commercially available conduit if required.

These cables are secured at the back of the control panel using cable clamps (cable clamps supplied in a separate pack) that are to be installed on the sheet metal.

## 40 BASIC CONNECTIONS

1. To gain access to the connection strip, unscrew the three screws on the rear of the control panel and open the panel.
2. Pass the connecting cables to the control panel through the two cut-outs in the rear panel of the boiler and route them to the front via the cable channels. (See Frame 30).
3. Pass the cables into the control panel through the rectangular openings in the front top panel.
4. Secure the cables to the base of the control panel with the cable clamps.
5. Connect the main supply to terminals 1, 2 and 3 of the connecting strip as shown. (See also Frame 41)

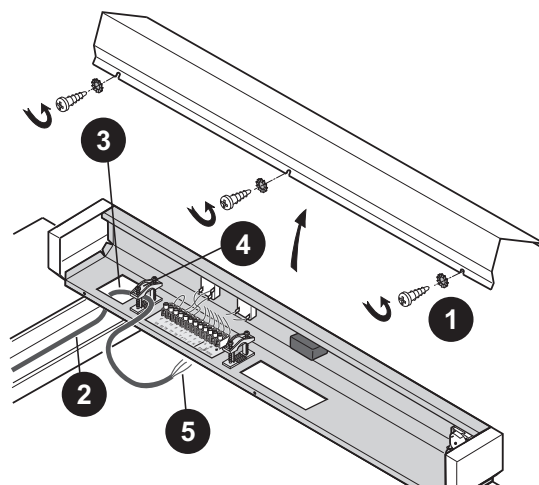

## 41 CONNECTING OPTIONAL FEATURES

### Flow Switch / Optional Safety Devices

If a flow switch or other safety control is to be included in the system, connect the device(s) in series in the safety circuit, (i.e. between terminal 5 of the connecting strip and burner terminal L1).

### Burner Alarm Indicator

If an alarm indicator is to be included it should be connected across terminal 12 (live) and terminal 4 (neutral).

### Safety Thermostat Alarm Indicator System

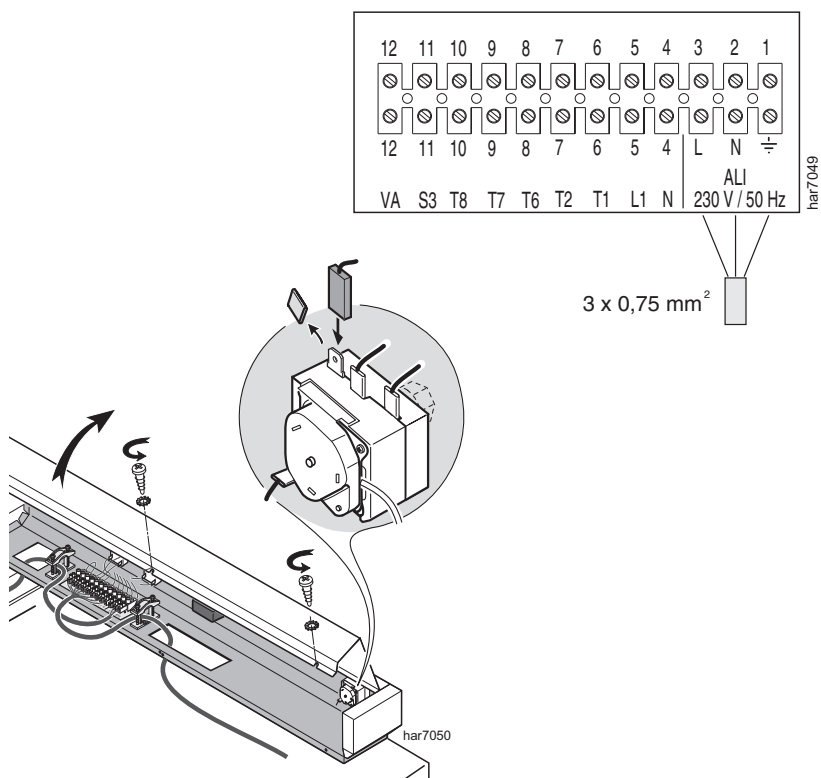

1. The unused insulated terminal on the safety thermostat may be used to connect an alarm signal. (This terminal becomes live if the safety thermostat trips.)
2. Remove the insulation and connect the live wire from the alarm indicator to the unused terminal using a suitable spade connector and the neutral to terminal 4.

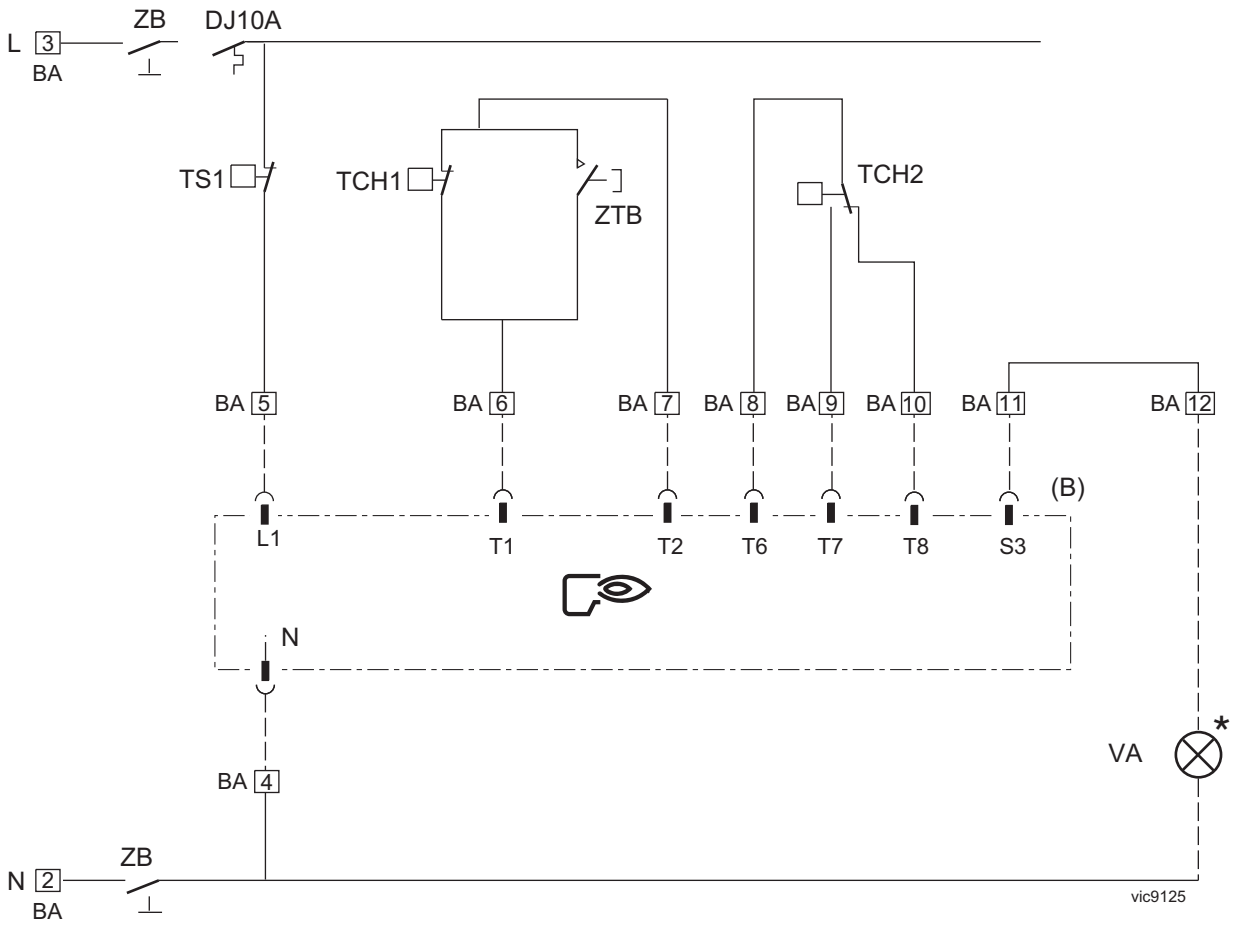

# INSTALLATION

## 42 WIRING DIAGRAM



- |   |                           |
|---|---------------------------|
| <b>B</b>  | Burner                    |
| <b>BA</b>   | Connection strip          |
| <b>DJ10A</b>  | 10A circuit-breaker       |
| <b>L</b>  | Live                      |
| <b>N</b>  | Neutral                   |
| <b>TCH1</b>   | Stage 1 boiler thermostat |
| <b>TCH2</b>   | Stage 2 boiler thermostat |
| <b>TS1</b>  | Safety thermostat         |
| <b>VA</b>   | Alarm indicator           |
| <b>ZB</b>   | Burner switch             |
| <b>ZTB</b>  | STB-Test switch           |
|  | Connecting strip          |
| <b>*</b>  | Optional                  |
|  | Connector                 |

## 43 BURNER WIRING HARNESS

### Burner Cable

The control panel is supplied with a burner power supply cable, with one 7 and one 4-pin European plugs on one end and a terminal block with male connecting terminals on the other end.

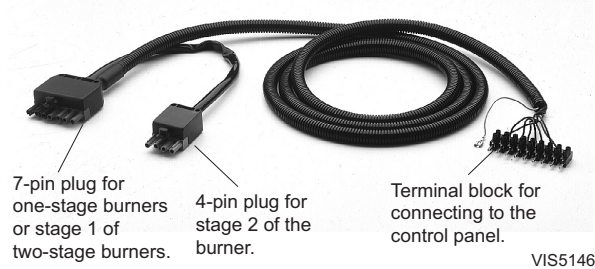

### Control Panel Connections

Connect the terminal block with the male connecting terminals to terminals 4-12 in the control panel.

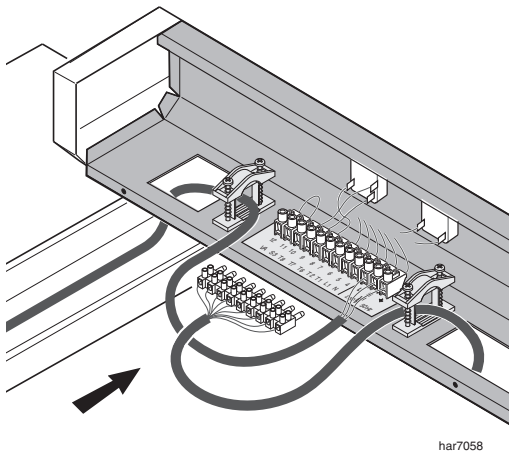

### Burner Connections without Plug-in Connectors

In this case, the connectors supplied with the burner cable must be rewired.

The diagram shows the wire numbers and terminals of the burner connectors.

The table below specifies the way in which the cables are to be connected to the burner control box.

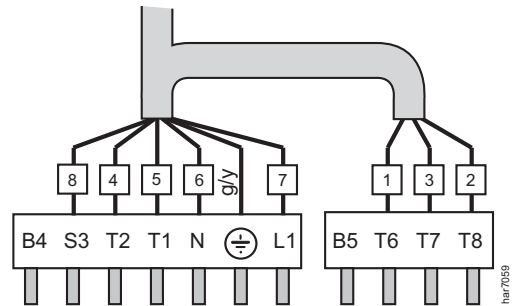

Burner Connector Terminal No.	Wire No.	From	Connection to the Burner Control Box
L1	7	Permanent Live supply from the safety thermostat	Burner main supply
⊕	g/y	Earth connection	Earth connection
N	6	Neutral taken after On/Off Switch	Neutral terminal
T1/T2	5/4	Volt free contact of the stage 1 boiler thermostat	Insert in the control circuit of boiler stage 1
S3	8	Burner alarm indicator	Alarm output (live)
T6	1	Stage 2 boiler thermostat input	Insert in the control circuit of burner stage 2
T7	3	Stage 2 "boiler off" thermostat output	Connect only if the burner is of the modulating type
T8	2	Stage 2 "boiler on" thermostat output	Insert in the control circuit of burner stage 2

### Note.

If the electrical characteristics of the burner exceed the following values:

- start up current > 16 A or
- Max. Power > 450 W (or 1/2 cont. hp. motor), or
- Max. Current > 2A cos φ = 0,7

The burner controls circuit must use a relay.

## 44 FUEL OIL OR GAS CONNECTIONS

Refer to the instructions supplied with the burner.

# INSTALLATION

## 45 COMMISSIONING

**IMPORTANT.** Domestic hot water circuits (if they exist) and heating circuits must have been filled and bled, and leak tightness tests must have been carried out on them, in accordance with the instructions for the domestic hot water calorifier (if existing) and boiler.

Refer to the following instructions and Frame 48 to start up the boiler.

- the instructions delivered with the burner.
- the instructions delivered with the domestic hot water calorifier, (if existing).

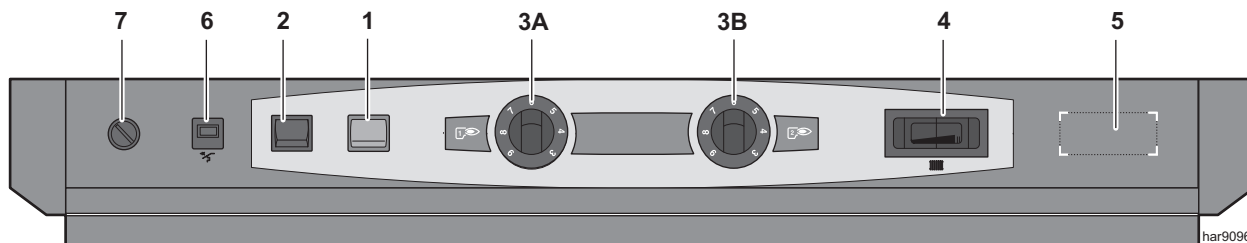

- 1. Boiler ON/OFF switch.**  
Position  $\odot$ .....ON Position  $\circ$ .....OFF
- 2. TEST STB:**  
When held in the pressed (momentary use) position it tests the safety thermostat.  
**Note.** If two stage burner control fitted operation will continue on 1st stage after 2nd stage cut-off.
- 3. Boiler Thermostats:**  
Adjustment range 30-90°C  
For ON/OFF burners use 1st stage thermostat only.  
For two stage burners set 2nd stage 5°C below 1st stage setting.
- 4. Boiler Thermometer**
- 5. Location for Flue Gas Thermometer (Optional)**
- 6. Timed Circuit Breaker:**  
10A with delayed action and manual reset.
- 7. Safety Thermostat:**  
Set at 110°C. Manual reset.

## 46 BOILER THERMOSTAT (Maximum Setting Adjustment)

The boiler thermostats maximum setting are factory set at 75°C. The fixed stop controlling the maximum setting is adjustable as follows:

1. Carefully remove the control knob.
2. Pull out the pin from the back of the knob.
3. Relocate in the desired position.
4. Carefully replace the knob ensuring that the new pin position is at the correct side of the stop.
5. Rotate the knob to the new desired maximum position to check correct setting. (The setting numbers 3-9 are approximately scaled to represent 30-90°C).

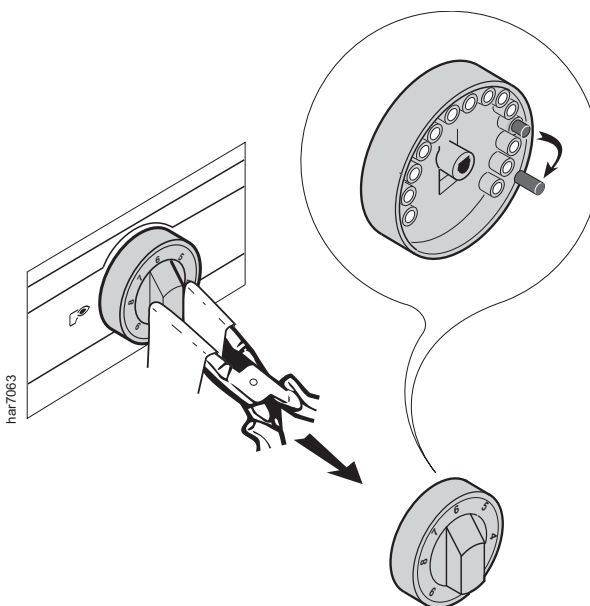

## 47 COMMISSIONING AND TESTING

### A. ELECTRICAL INSTALLATION

1. Checks to ensure electrical safety should be carried out by a competent person.
2. ALWAYS carry out the preliminary electrical system checks, i.e. earth continuity, polarity, resistance to earth and short circuit, using a suitable meter.

### B. FOR GAS INSTALLATION

1. The whole of the gas installation, including the meter, should be inspected and tested for soundness and then purged in accordance with the recommendations of the relevant standards listed on page 4.

**WARNING.** Whilst effecting the required gas soundness test and purging air from the gas installation, open all windows and doors, extinguish naked lights and DO NOT SMOKE.

## 48 INITIAL LIGHTING

1. Check that the system has been filled and the boiler is not air locked - air in the boiler could damage the heat exchanger.
2. Check that all the drain cocks are closed and any valves in the flow and return are open.
3. Check that the GAS SERVICE COCK IS ON.
4. Unscrew the safety thermostat (overheat) reset button cap (7) and press the reset button.
5. Set the boiler thermostats (3) to maximum.
6. Switch the electricity supply ON and check that all the external controls are calling for heat. Set the main boiler switch (1) to ON (Ⓢ).
7. The burner will commence the ignition sequence. If the burner has failed to light then it will lock out. Press the reset button to restart the ignition sequence.
8. Operate the boiler for 20 minutes and for gas fired boilers check the gas rate (Table 1).
9. Refer to the burner instructions for specific operating features.
10. Set the boiler thermostats (3) to the appropriate settings ensuring the second stage is 5°C lower than the first stage if a 2 stage burner is fitted.

## 49 GENERAL CHECKS

Make the following checks for correct operation.

1. The correct operations of ANY secondary system controls should be proved. Operate each control separately and check that the main burner or circulating pump, as the case may be responds.
2. Water circulation system;
  - a. With the system HOT examine all water connections for soundness.
  - b. With the system still HOT, turn off the gas or oil burner, water and electricity supplies to the boiler and drain down to complete the flushing process.
  - c. Refill and vent the system, clear all air locks and again check for water soundness.
  - d. Balance the system.
3. Finally set the controls to the User's requirements.

**Note.**

*We advise never to set the boiler thermostat below position 4 (approx. 40°C) in order to avoid the risk of combustion products condensing on the walls of the boiler.*

## 50 HANDING OVER

### ROUTINE OPERATION

Describe the function of the boiler and system controls and show how they are adjusted and used.

Hand these Installation and Servicing Instructions, User's Instructions and Log book to the customer and request him to keep them in a safe place for ready reference.

**IMPORTANT.** Point out the owner that the boiler must have regular maintenance and cleaning, at least annually, in order to ensure reliable and efficient operation. Regular attention will also prolong the life of the boiler and should preferably be performed at the end of the heating season.

Recommend that a contract for this work should be made with the regional gas authority or a CORGI registered heating installer for gas fired boilers.

## 51 MAINTENANCE

### WARNING

The operations described below shall always be performed with the boiler and the power supply switch off.

The boiler front panel has to be removed to access the various devices to be maintained and checked.

1. Unhook the front panels and remove.

### Cleaning the Casing Material

Use a soapy solution and sponge only. Rinse with clean water and dry with chamois leather or soft cloth.

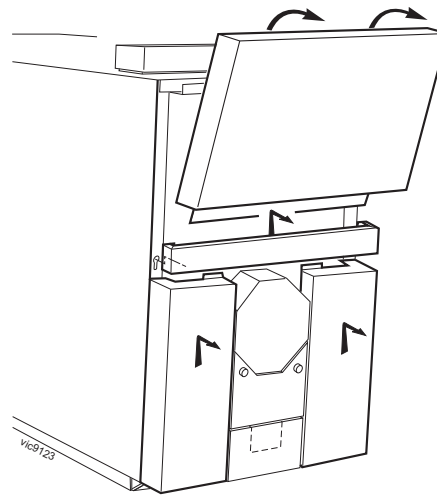

## 52 CLEANING THE FLUEWAYS

1. Close off the fuel supply to the burner.
2. Ensure that the boiler has been cooled to ambient temperature.
3. Isolate the mains supply to the boiler and burner.
4. Disconnect the cable and supply pipe to the burner.
5. Open the combustion chamber (four nuts) and flue way (three nuts) doors by removing the nuts.
6. Remove the flue way baffles.
7. Thoroughly clean the flue ways and baffles.
8. Release and allow to swing down the rear cleanout covers by undoing the two upper nuts and loosening the two lower nuts. Dispose of the debris/soot that may have accumulated.
9. Replace the rear cleanout covers after first inspecting and if necessary replacing the seal.
10. Brush out the combustion chamber and vacuum the soot from beneath the flue ways.
11. Replace the flue baffles into the flue ways (refer to Frame 25 for number and location).
12. Check the condition of the combustion chamber door insulation and replace if necessary.
13. Check the condition of the combustion chamber door seal and replace if necessary.
14. Refer to the burner manufacturer's Instructions for burner maintenance.

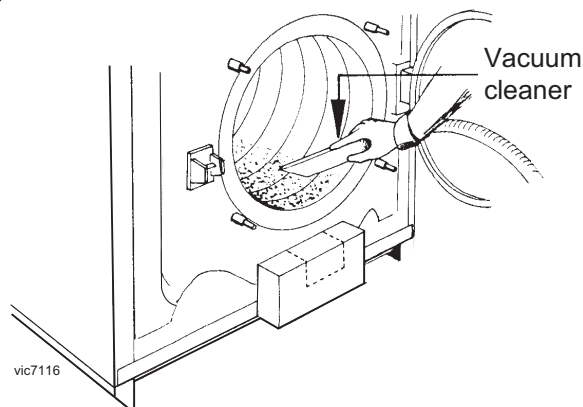
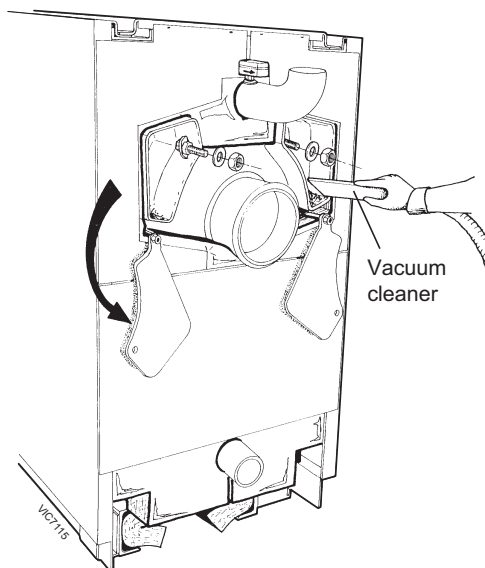
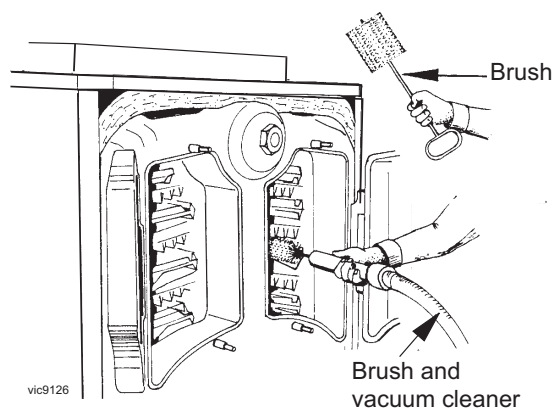

## 53 SYSTEM MAINTENANCE

### Water Level

Check the water level in the installation regularly and if necessary top it up without allowing a sudden inlet of cold water into the hot boiler.

The operation should only be necessary a few times per season; if it has to be done more frequently, there is probably a leak which should be found and corrected without delay.

### Safety Devices

Check that safety devices, particularly the heating circuit safety valve, are working correctly at regular intervals and at least when the boiler is cleaned.

### Draining

It is recommended that the installation should not be emptied unless absolutely necessary.

For example: when leaving for several months and/or there is a risk of frost in the building.

## 54 SAFETY

For boilers with gas burners:

It is the law that any service work must be carried out by a registered CORGI installer.

**WARNING.** Always turn off the gas supply at the gas service cock, switch off and disconnect the electricity supply to the appliance and any external controls before servicing.

**IMPORTANT.** After completing the servicing or replacement of components always:

- Test for gas soundness.

- check the water system is correctly filled and free of air. Air in the boiler could cause damage to the heat exchanger.
- With the system hot examine all water connections for soundness.
- Check the gas rate and measure the combustion CO/CO<sub>2</sub> content.
- Complete the boiler log book.
- Carry out functional checks as appropriate.

## 55 SERVICING SCHEDULE

To ensure the continued safe and efficient operation of the appliance it is recommended that it is checked at regular intervals and serviced as necessary. The frequency of servicing will depend upon the installation condition and usage but should be carried out at least annually.

**Ideal Stelrad Group** does not accept any liability resulting from the use of unauthorised parts or the repair and servicing of appliances not carried out in accordance with the Company's recommendations and specifications.

1. Light the boiler and carry out function checks, noting any operational faults.
2. Run the boiler for 10 minutes and then check the burner rate.

3. Optional test for gas fired boilers - Connect a suitable gas analyser to the sampling point fitted in the flue adapter. For correct boiler operation the CO/CO<sub>2</sub> ratio of the flue gas should not be greater than 0.004 ratio. If this is the case and the gas input is at least 90% of the nominal, no further action need be taken. If not proceed to 4.
4. Remove and clean the burner.
5. Inspect the heat exchanger through the burner opening. Clean the flueways.
6. Check that the flue terminal is unobstructed and that the flue system is sealed correctly.
7. After completion of servicing refer to previous frame for reference to final safety checks.

## NOTES

## NOTES

## Technical Training

The Ideal Boilers Technical Training Centre offers a series of first class training courses for domestic, commercial and industrial heating installers, engineers and system specifiers. For details of courses please ring: ..... 01482 498 432

**Ideal Boilers**, P.O. Box 103, National Ave, Kingston upon Hull, HU5 4JN. Telephone: 01482 492 251 Fax: 01482 448 858. Registration No. London 322 137.

**Ideal Stelrad Group** pursues a policy of continuing improvement in the design and performance of its products. The right is therefore reserved to vary specification without notice.



**i Ideal** BOILERS  
The High Efficiency Pioneers

November 2008 UIN 203621 A03



Ideal Stelrad Group

***Ideal Commercial/Technical Helpline: 01482 498 376***  
***www.idealboilers.com***